

# T-REX 600 ESP EP-HELICOPTER INSTRUCTION MANUAL

## 使用說明書

Model:KX016013T(Black)

Model:KX016014T(Blue)



Thank you for buying ALIGN products. The **T-REX 600ESP** is the latest technology in Rotary RC models. Please read this manual carefully before assembling and flying the New **T-REX 600ESP** helicopter. We recommend that you keep this manual for future reference regarding tuning and maintenance.

承蒙閣下選用亞拓遙控世界系列產品，謹表謝意。進入遙控世界之前必須告訴您許多相關的知識與注意事項，以確保您能夠在學習的過程中較得心應手。在開始操作之前，請務必詳閱本說明書，相信一定能夠給您帶來相當大的幫助，也請您妥善保管這本說明書，以作為日後參考。



### Contents

1	INTRODUCTION 前言
1~2	SAFETY NOTES 安全注意事項
3	SAFETY CHECK BEFORE FLYING 飛行前安全檢查
4~18	ASSEMBLY SECTION 組裝說明
19	EQUIPMENT ILLUSTRATION 設備建議配置圖示
20	CANOPY ASSEMBLY 機頭罩安裝
20	SERVO AND LINKAGE ROD SETTING 伺服器與連桿設定說明
21	SERVO SETTING AND ADJUSTMENT 伺服器設定調整
21	ADJUSTMENTS FOR GYRO AND TAIL NEUTRAL SETTING 陀螺儀與尾翼中立點調整
22	PITCH AND THROTTLE SETTING 主旋翼螺距與油門設定
23	POWER COLLOCATION REFERENCE 原裝動力數據參考表
23~25	RCEBL100G BRUSHLESS SPEED CONTROLLER INSTRUCTION MANUAL 無刷調速器使用說明
25	6A EXTERNAL BEC INSTRUCTION MANUAL 6A外接式BEC使用說明
26~28	GP780 HEAD LOCK GYRO SET USER MANUAL GP780鎖定式陀螺儀
28~30	FLIGHT ADJUSTMENT AND SETTING 飛行動作調整與設定
31~38	PART NAMES AND OPTIONAL PART LIST 各部零件名稱與選購備品明細

Thank you for buying ALIGN Products. The T-REX 600 ESP Helicopter is designed as an easy to use, full featured Helicopter R/C model capable of all forms of rotary flight. Please read the manual carefully before assembling the model, and follow all precautions and recommendations located within the manual. Be sure to retain the manual for future reference, routine maintenance, and tuning. The T-REX 600 ESP is a new product developed by ALIGN. It provides flying stability for beginners, full aerobatic capability for advanced fliers, and unsurpassed reliability for customer support.

感謝您選購亞拓產品，為了讓您容易方便的使用 T-REX 600 ESP 直昇機、請您詳細的閱讀完這本說明書之後再進行組裝以及操作這台直昇機，同時請您妥善的保存這本說明書、作為日後進行調整以及維修的參考。T-REX 600 ESP 是由亞拓自行研發的新產品，不論你是需求飛行穩定性的初學者或是追求性能的飛行愛好者。T-REX 600 ESP 將是你最佳的選擇。

### THE MEANING OF SYMBOLS 標誌代表涵義

 <b>WARNING</b> 警告	<b>Mishandling due to failure to follow these instructions may result in damage or injury.</b> 因為疏忽這些操作說明，而使用錯誤可能造成財產損失或嚴重傷害。
 <b>CAUTION</b> 注意	<b>Mishandling due to failure to follow these instructions may result in danger.</b> 因為疏忽這些操作說明，而使用錯誤可能造成危險。
 <b>FORBIDDEN</b> 禁止	<b>Do not attempt under any circumstances.</b> 在任何禁止的環境下，請勿嘗試操作。

### IMPORTANT NOTES 重要聲明

**R/C helicopters, including the T-REX 600 ESP are not toys. R/C helicopter utilize various high-tech products and technologies to provide superior performance. Improper use of this product can result in serious injury or even death. Please read this manual carefully before using and make sure to be conscious of your own personal safety and the safety of others and your environment when operating all ALIGN products.**

**Manufacturer and seller assume no liability for the operation or the use of this product.**

**Intended for use only by adults with experience flying remote control helicopters at a legal flying field. After the sale of this product we cannot maintain any control over its operation or usage.**

T-REX 600 ESP 遙控直昇機並非玩具，它是結合了許多高科技產品所設計出來的休閒用品，所以商品的使用不當或不熟悉都可能造成嚴重傷害甚至死亡，使用之前請務必詳讀本說明書，勿輕忽並注意自身安全。注意!任何遙控直昇機的使用，製造商和經銷商是無法對使用者於零件使用的損耗異常或組裝不當所發生之意外負任何責任，本產品是提供給有操作過模型直昇機經驗的成人或有相當技術的人員在旁指導於當地合法遙控飛行場飛行，以確保安全無虞下操作使用，產品售出後本公司將不負任何操作和使用控制上的任何性能與安全責任。

**We recommend that you obtain the assistance of an experienced pilot before attempting to fly our products for the first time. A local expert is the best way to properly assemble, setup, and fly your model for the first time. The T-REX 600 ESP requires a certain degree of skill to operate, and is a consumer item. Any damage or dissatisfaction as a result of accidents or modifications are not covered by any warranty and cannot be returned for repair or replacement. Please contact our distributors for free technical consultation and parts at discounted rates when you experience problems during operation or maintenance.**

模型商品屬於需高操作技術且為消耗性之商品，如經拆裝使用後，會造成不等情況零件損耗，任何使用情況所造成商品不良或不滿意，將無法於保固條件內更換新品或退貨，如遇有使用操作維修問題，本公司全省分公司或代理商將提供技術指導、特價零件供應服務。

## 2. SAFETY NOTES 安全注意事項



**Fly only in safe areas, away from other people. Do not operate R/C aircraft within the vicinity of homes or crowds of people. R/C aircraft are prone to accidents, failures, and crashes due to a variety of reasons including, lack of maintenance, pilot error, and radio interference. Pilots are responsible for their actions and damage or injury occurring during the operation or as of a result of R/C aircraft models.**

遙控模型飛機、直昇機屬高危險性商品，飛行時務必遠離人群，人為組裝不當或機件損壞、電子控制設備不良，以及操控上的不熟悉、都有可能導致飛行失控損傷等不可預期的意外，請飛行者務必注意飛行安全，並需了解自負疏忽所造成任何意外之責任。



### LOCATE AN APPROPRIATE LOCATION 遠離障礙物及人群

R/C helicopters fly at high speed, thus posing a certain degree of potential danger. Choose an a legal flying field consisting of flat, smooth ground without obstacles. Do not fly near buildings, high voltage cables, or trees to ensure the safety of yourself, others and your model. For the first practice, please choose a legal flying field and can use a training skid to fly for reducing the damage. Do not fly your model in inclement weather, such as rain, wind, snow or darkness.

直昇機飛行時具有一定的速度，相對的也潛在著危險性，場地的選擇也相對的重要，請需遵守當地法規到合法搖控飛行場地飛行。必須注意周遭有沒有人、高樓、建築物、高壓電線、樹木等等，避免操控的不當造成自己與他人財產的損壞。初次練習時，務必選擇在空曠合法專屬飛行場地並適當搭配練習架練習飛行，這對飛行失誤所造成的損傷將會大幅的降低。請勿在下雨、打雷等惡劣天候下操作，以確保本身及機體的安全。



### PREVENT MOISTURE 遠離潮濕環境

R/C models are composed of many precision electrical components.

It is critical to keep the model and associated equipment away from moisture and other contaminants. The introduction or exposure to water or moisture in any form can cause the model to malfunction resulting in loss of use, or a crash. Do not operate or expose to rain or moisture.

直昇機內部也是由許多精密的電子零組件組成，所以必須絕對的防止潮濕或水氣，避免在浴室或雨天時使用，防止水氣進入機身內部而導致機件及電子零件故障而引發不可預期的意外！



### PROPER OPERATION 勿不當使用本產品

Please use the replacement of parts on the manual to ensure the safety of instructors. This product is for R/C model, so do not use for other purpose.

請勿自行改造加工，任何的升級改裝或維修，請使用亞拓產品目錄中的零件，以確保結構的安全。請確認於產品限界內操作，請勿過載使用，並勿用於安全、法令外其它非法用途。



### OBTAIN THE ASSISTANCE OF AN EXPERIENCED PILOT 避免獨自操控

Before turning on your model and transmitter, check to make sure no one else is operating on the same frequency. Frequency interference can cause your model, or other models to crash. The guidance provided by an experienced pilot will be invaluable for the assembly, tuning, trimming, and actual first flight. (Recommend you to practice with computer-based flight simulator.)

至飛行場飛行前，需確認是否有相同頻率的好手正進行飛行，因為開啓相同頻率的發射機將導致自己與他人立即干擾等意外危險。遙控飛機操控技巧在學習初期有著一定的難度，要盡量避免獨自操作飛行，需有經驗的人士在旁指導，才可以操控飛行。(勤練電腦模擬器及老手指導是入門必要的選擇)



### SAFE OPERATION 安全操作

Operate this unit within your ability. Do not fly under tired condition and improper operation may cause in danger.

請於自己能力內及需要一定技術範圍內操作這台直昇機，過於疲勞、精神不佳或不當操作，意外發生風險將可能會提高。



### ALWAYS BE AWARE OF THE ROTATING BLADES 遠離運轉中零件

During the operation of the helicopter, the main rotor and tail rotor will be spinning at a high rate of speed. The blades are capable of inflicting serious bodily injury and damage to the environment. Be conscious of your actions, and careful to keep your face, eyes, hands, and loose clothing away from the blades. Always fly the model a safe distance from yourself and others, as well as surrounding objects. Never take your eyes off the model or leave it unattended while it is turned on. Immediately turn off the model and transmitter when you have landed the model.

當直昇機主旋翼與尾旋翼運轉時，切勿觸摸並遠離任何物件，以避免造成危險及損壞。



### KEEP AWAY FROM HEAT 遠離熱源

R/C models are made up various forms of plastic. Plastic is very susceptible to damage or deformation due to extreme heat and cold climate. Make sure not to store the model near any source of heat such as an oven, or heater. It is best to store the model indoors, in a climate-controlled, room temperature environment.

遙控飛機多半是以 PA 纖維或聚乙烯、電子商品為主要材質，因此要盡量遠離熱源、日曬，以避免因高溫而變形甚至熔毀損壞的可能。



#### CAREFULLY INSPECT BEFORE REAL FLIGHT 實機飛行前請嚴格執行飛行前檢查義務

- ☆ **Before flying, please check to make sure no one else is operating on the same frequency for the safety.**
  - ☆ **Before flight, please check if the batteries of transmitter and receiver are enough for the flight.**
  - ☆ **Before turn on the transmitter, please check if the throttle stick is in the lowest position. IDLE switch is OFF.**
  - ☆ **When turn off the unit, please follow the power on/off procedure. Power ON- Please turn on the transmitter first, and then turn on receiver. Power OFF- Please turn off the receiver first and then turn off the transmitter. Improper procedure may cause out of control, so please to have this correct habit.**
  - ☆ **Before operation, check every movement is smooth and directions are correct. Carefully inspect servos for interference and broken gear.**
  - ☆ **Check for missing or loose screws and nuts. See if there is any cracked and incomplete assembly of parts. Carefully check main rotor blades and rotor holders. Broken and premature failures of parts possibly cause resulting in a dangerous situation.**
  - ☆ **Check all ball links to avoid excess play and replace as needed. Failure to do so will result in poor flight stability.**
  - ☆ **Check the battery and power plug are fastened. Vibration and violent flight may cause the plug loose and result out of control.**
- ★ 每次飛行前應先確認所使用的頻率是否會干擾他人，以確保你自身與他人的安全。
- ★ 每次飛行前確定您發射機與接收機電池的電量是在足夠飛行的狀態。
- ★ 開機前確認油門搖桿是否位於最低點，熄火降落開關，定速開關(IDLE)是否於關閉位置。
- ★ 關機時必須遵守電源開關機的程序，開機時應先開啓發射機後，再開啓接收機電源；關機時應先關閉接收機後，再關閉發射機電源。不正確的開關程序可能會造成失控的現象，影響自身與他人的安全，請養成正確的習慣。
- ★ 開機請先確定直昇機的各個動作是否順暢，及方向是否正確，並檢查伺服器的動作是否有干涉或崩齒的情形，使用故障的伺服器將導致不可預期的危險。
- ★ 飛行前確認沒有缺少或鬆脫的螺絲與螺帽，確認沒有組裝不完整或損毀的零件，仔細檢查主旋翼是否有損壞，特別是接近主旋翼夾座的部位。損壞或組裝不完整的零件不僅影響飛行，更會造成不可預期的危險。注意：對損耗、有裂痕零件更新及定期保養檢查的重要性。
- ★ 檢查所有的連桿頭是否有鬆脫的情形，過鬆的連桿頭應先更新，否則將造成直昇機無法操控的危險。
- ★ 確認電池及電源接頭是否固定牢靠，飛行中的震動或激烈的飛行，可能造成電源接頭鬆脫而造成失控的危險。

Standard Equipment 標準配備					
<b>50HZ005</b>	<b>600NH</b>	<b>50HB</b>	<b>50HB007</b>	<b>600NB3</b>	<b>600NG</b>
<b>50HT012</b>	<b>600HT</b>	<b>50HT001-2</b>	<b>600NZ</b>	<b>DS610 Digital Servo x 3</b> DS610數位伺服器 x 3	<b>GP780 Head Lock Gyro Combo</b> GP780鎖式陀螺儀組(GP780+DS620)
<b>RCE-BL100G Brushless ESC (Governor Mode)</b> RCE-BL100G 100安培無刷定速調速器	<b>6A External BEC w/ 5.1V Two-way Step-down voltage regulator</b> 6A外接式BEC(含5.1雙向降壓器)	<b>Li-Polymer 7.4V 1900mAh 40C</b>	<b>RCM-BL600M Motor</b> RCM-BL600M無刷馬達	<b>600D Carbon Fiber Blade</b> 600D碳纖維主旋翼	

When you see the marks as below, please use glue or grease to ensure flying safety.

標有下符號之組裝步驟，請配合上膠或上油，以確保使用之可靠度。



- CA: Apply CA Glue to fix.
  - R48: Apply Anaerobics Retainer to fix.
  - T43: Apply Thread Lock to fix.
  - OIL: Add Grease.
- CA: 使用瞬間膠固定  
R48: 使用金屬管狀固定缺氧膠固定  
T43: 使用螺絲膠  
OIL: 添加潤滑油

When assembling ball links, make sure the "A" character faces outside.

各項塑膠製連桿頭扣接時，A字請朝外。

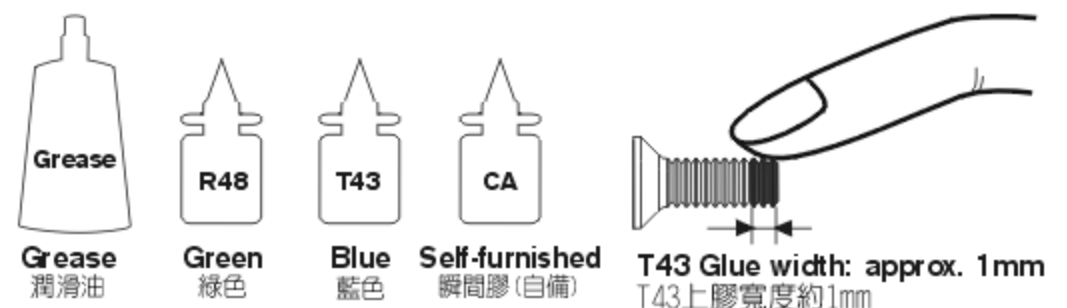

R48 metal tubular adhesive (eg. Bearings). T43 thread lock, apply a small amount on screws or metal parts and wipe surplus off. When disassembling, recommend to heat the metal joint about 15 Seconds. (NOTE: Keep plastic parts away from heat.)  
R48 為強力金屬管狀(如軸承)接著劑，T43為螺絲膠，膠合螺絲或金屬內外徑請務必少量使用，必要時請用手去除多餘膠量，欲拆卸時可於金屬接合部位熱烤約15秒。(注意！塑膠件避免接近熱源)

600NH6

Apply a little amount of T43 thread lock when fixing a metal part.  
螺絲鎖附於金屬件請使用適量T43(螺絲膠)

**Linkage ball F(M3.5x4)**  
球頭F (M3.5x4) (φ4.75x20.25mm) x2

600NH6A

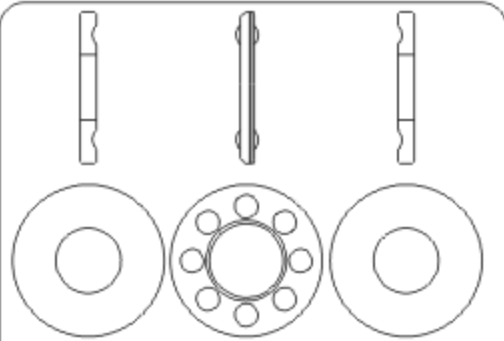

**Thrust bearing**  
止推軸承(φ6xφ14x5mm) x2

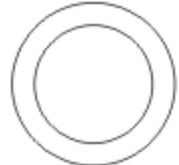

**Spindle bearing spacer**  
橫軸軸承墊片(φ10xφ13.8x0.4mm) x2

**Main Blade Fixing Screw**  
鎖主旋翼用螺絲



**Socket collar screw**  
圓頭內六角軸套螺絲(M4x27mm) x2

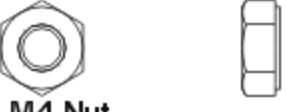

**M4 Nut**  
M4防鬆螺帽 x2



**Bearing**  
軸承(φ8xφ14x4mm) x4



**Spindle bearing spacer**  
橫軸軸承墊片(φ10xφ13.8x0.4mm) x2

**CAUTION**  
注意

Apply grease on thrust bearing.  
止推軸承塗上潤滑油

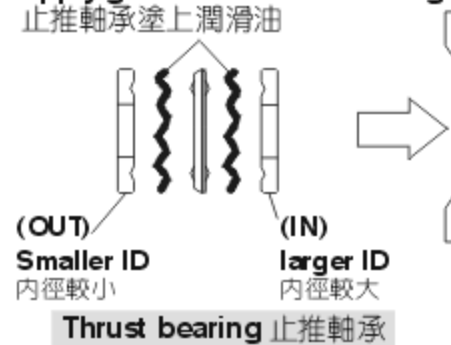

**CAUTION**  
注意

When tightening a linkage ball to a plastic part, please note to use a little CA glue and tighten it firmly, but not over tightened, or they will strip.  
球頭鎖入塑膠件請務必注意，使用少量CA膠並適當扭力鎖緊即可，而過緊的扭力可能會導致滑牙。

**Thrust bearing**  
止推軸承  
φ6xφ14x5mm

**Spindle bearing spacer**  
橫軸軸承墊片  
φ10xφ13.8x0.4mm

**Bearing**  
軸承  
φ8xφ14x4mm

**Collar**  
金屬主旋翼夾座襯套  
φ4xφ6xφ9x4.3mm

**Obverse of bearing faces inside.**  
軸承面凹開口朝內

**Metal main rotor holder**  
金屬主旋翼夾座

**Linkage ball F(M3.5x4)**  
球頭F (M3.5x4)  
φ4.75x20.25mm

600NH2C

Apply a little amount of T43 thread lock when fixing a metal part.  
螺絲鎖附於金屬件請使用適量T43(螺絲膠)

**Feathering shaft sleeve**  
橫軸支撐套(φ8xφ10x31mm) x1



**Damper rubber-gray 70°**  
橫軸墊圈 灰70° (φ7.9xφ13x6.5mm) x2



**Damper rubber-black 80°**  
橫軸墊圈 黑色80° (φ7.9xφ13x6.5mm) x2



**Spacer**  
橫軸套圈(φ8xφ11.5x1.3mm) x2

600NH2

**Socket screw**  
圓頭內六角螺絲(M4x10mm)x2



**Washer**  
橫軸華司(φ4xφ12x1mm)x2

**Metal main rotor housing**  
金屬主旋翼固定座

**Feathering shaft sleeve**  
橫軸支撐套  
φ8xφ10x31mm

**Feathering shaft sleeve**  
橫軸支撐套  
φ8xφ10x31mm

**Feathering shaft**  
橫軸  
φ6xφ8x93.2mm

Apply grease  
塗上潤滑油

**Spacer (Copper)**  
橫軸套圈(銅)  
φ8xφ11.5x1.3mm

**Damper rubber**  
橫軸墊圈(橡膠)  
φ7.9xφ13x6.5mm

**Pin**  
定位插梢  
φ2x32mm

**Damper rubber-gray 70° is suitable to general flight for beginners.**  
橫軸墊圈灰色70°適用於一般飛行，適合初階者使用  
**Damper rubber-black 80° is suitable to 3D flight for advanced users.**  
橫軸墊圈黑色80°適用於3D飛行，適合高階者使用

**CAUTION**  
注意

**ALIGN logo on the top**  
字樣朝上

**Washer**  
橫軸華司  
φ4xφ12x1mm

**Socket screw**  
圓頭內六角螺絲  
M4x10mm

## 600NH2

Apply a little amount of T43 thread lock when fixing a metal part.  
螺絲鎖附於金屬件請使用適量T43(螺絲膠)

- Linkage ball A(M3x4)**  
球頭A (M3x4) (φ4.75x8.68mm) x 2
- Linkage ball B(M3x3)**  
球頭B (M3x3) (φ4.75x9.77mm) x 2
- Socket button head screw**  
半圓頭內六角螺絲(M3x12mm) x 2
- M3 collar screw**  
M3雙層軸套螺絲(M3x9.6mm) x 2
- Washer**  
華可(φ3xφ4.8x0.3mm) x 4
- Collar**  
擺臂軸承襯套(φ3xφ4.8x1.5mm) x 2
- Bearing**  
軸承(φ3xφ8x3mm) x 2
- Bearing**  
軸承(φ3xφ7x3mm) x 4
- Bearing**  
軸承(φ4xφ7x2.5mm) x 2

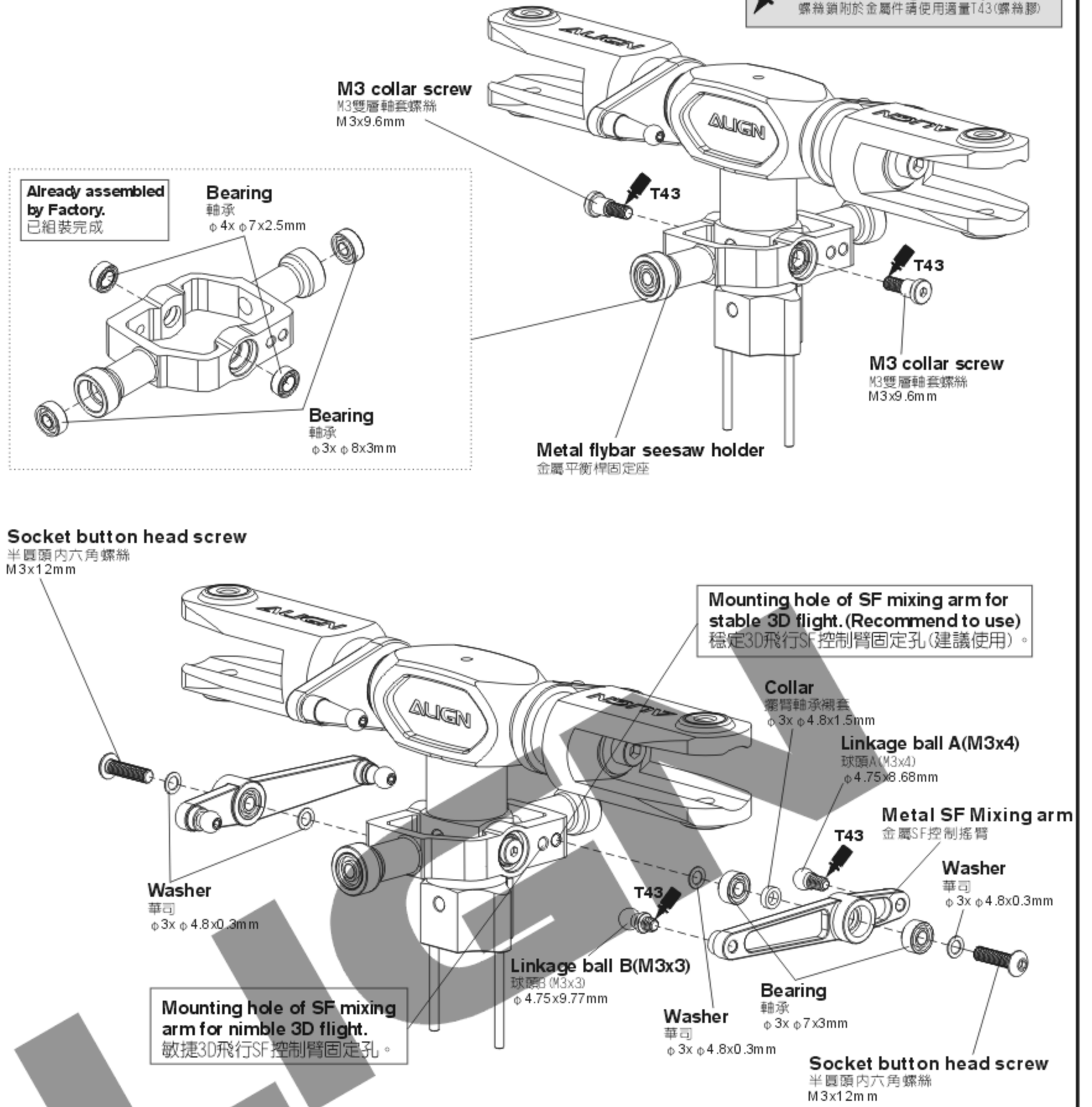

## 600NH7

- M3 Set screw**  
M3止洩螺絲(M3x3mm) x 4
- M4 Set screw**  
M4止洩螺絲(M4x4mm) x 2
- Socket screw**  
圓頭內六角螺絲(M3x5mm) x 4

## 600NH7A

- Linkage rod(B)**  
連桿(B) φ1.96x19mm x 2
- Ball link**  
連桿頭 x 4





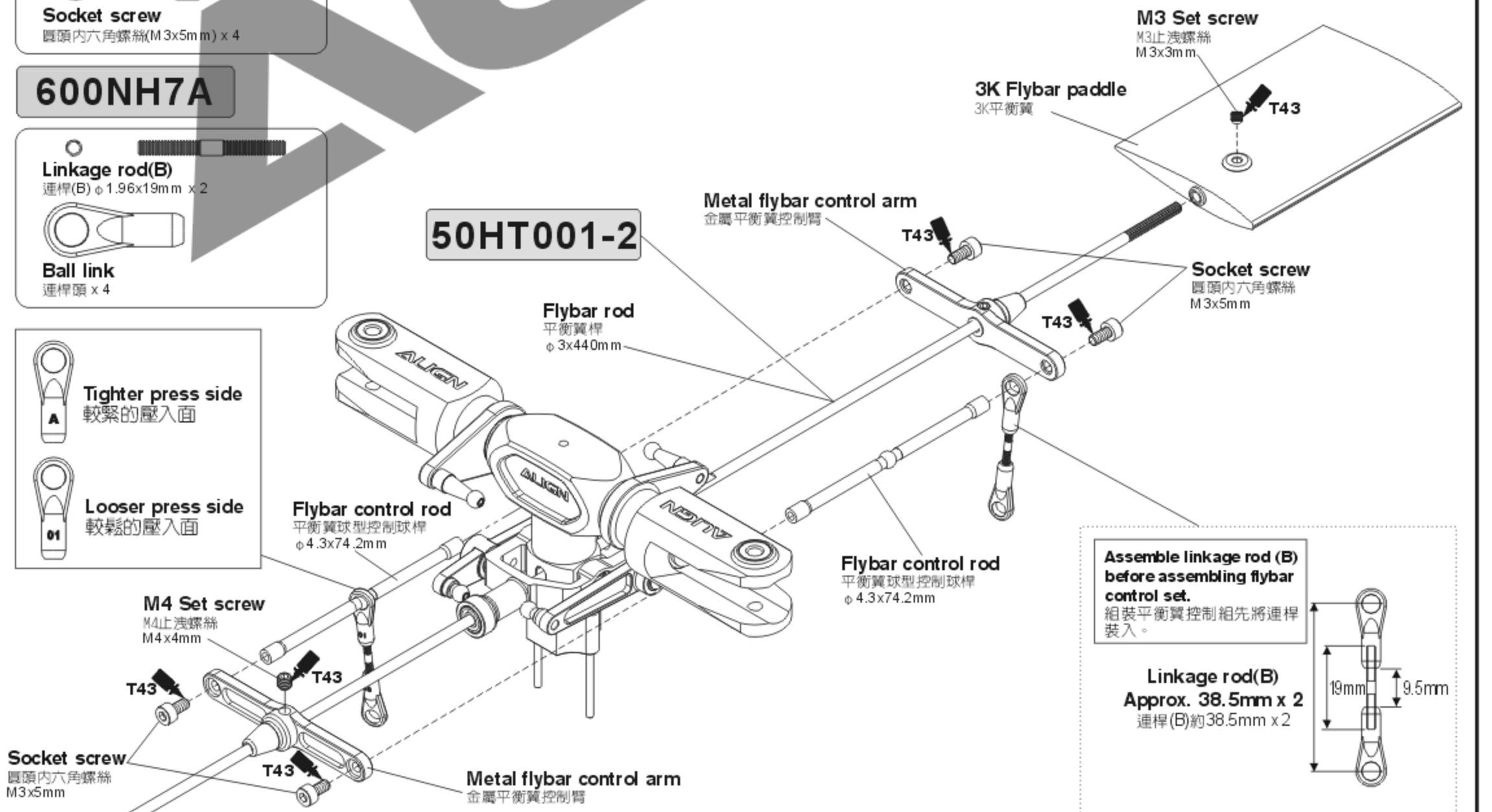



- Tighter press side**  
較緊的壓入面
- Looser press side**  
較鬆的壓入面

## 50HT001-2



# 50HH008

Apply a little amount of T43 thread lock when fixing a metal part.  
螺絲鎖附於金屬件請使用適量T43(螺絲膠)

-  **Socket collar screw**  
圓頭內六角軸套螺絲(M3x22mm) x1
-  **M3 Nut**  
M3防鬆螺帽 x1
-  **Bearing**  
軸承(φ3xφ7x3mm)x4
-  **Bearing**  
軸承(φ2xφ5x2.3mm) x4
-  **Socket screw**  
圓頭內六角螺絲(M2x5mm) x4
-  **Socket button head screw**  
半圓頭內六角螺絲(M3x12mm) x2
-  **Washer**  
華司(φ3xφ4.8x0.3mm) x2
-  **Collar**  
擺臂軸承襯套(φ3xφ4.8x1.5mm) x2
-  **Linkage ball B(M3x3)**  
球頭B(M3x3)(φ4.75x9.77mm) x2

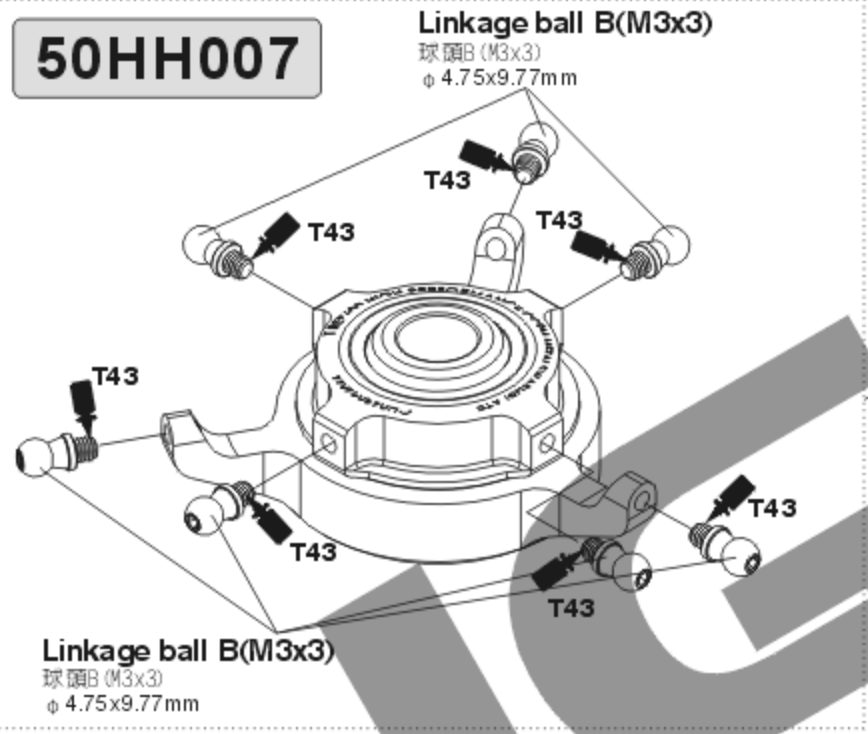
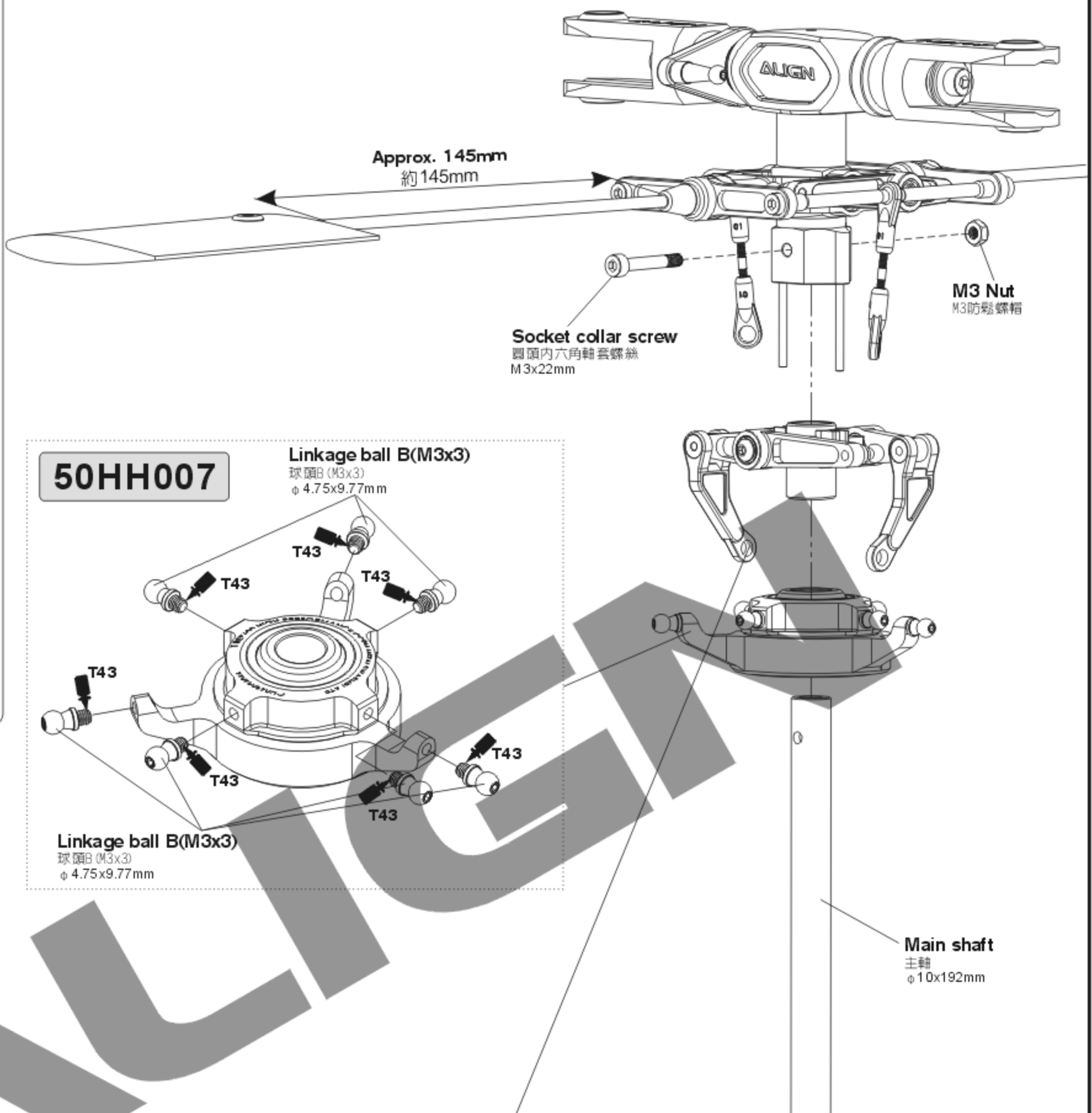

**CAUTION**  
注意

Already assembled by Factory.  
Before flying, please check if  
the screws are fixed with glue.  
原裝相裝完成品，每一次飛行前請  
先確認螺絲是否已上膠不會鬆動。

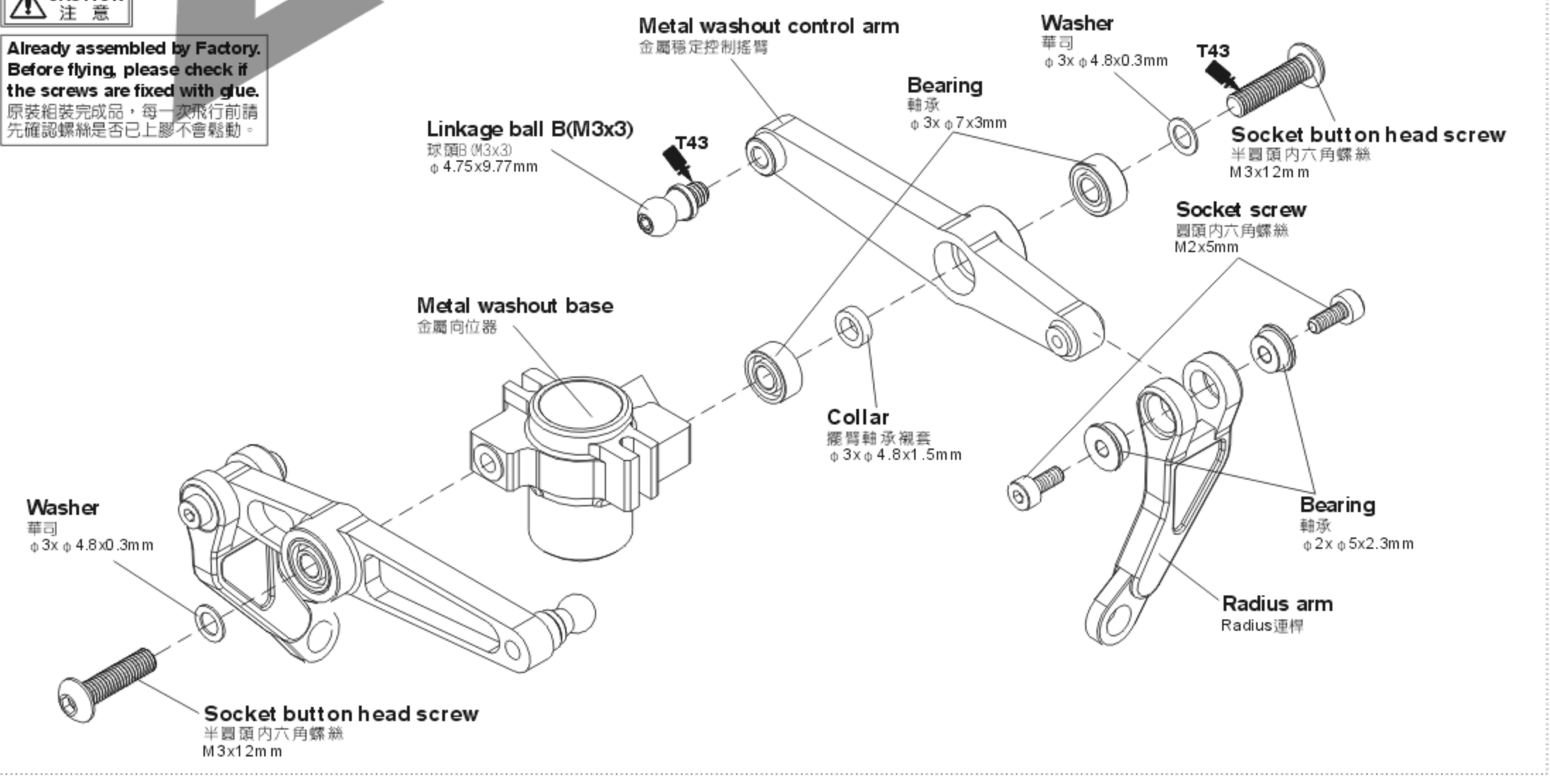

# 50HZ009

**Linkage rod(A)**  
連桿(A) φ1.96x14mm x 2

**Linkage rod(C)**  
連桿(C) φ1.96x48mm x 2

# 50HZ009A

**Ball link**  
連桿頭 x 8

# 600NH2C

**Socket screw**  
圓頭內六角螺絲(M3x10mm) x 1

Apply a little amount of T43 thread lock when fixing a metal part.  
螺絲鎖附於金屬件請使用適量T43(螺絲膠)

**Socket screw**  
圓頭內六角螺絲  
M3x10mm

**Metal head stopper**  
金屬旋簧頭制動器

**Linkage rod(A)**  
Approx. 31mm x 2  
連桿(A)約31mm x 2

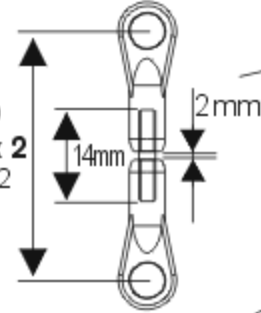

**Linkage rod(B)**  
Approx. 38.5mm x 2  
連桿(B)約38.5mm x 2

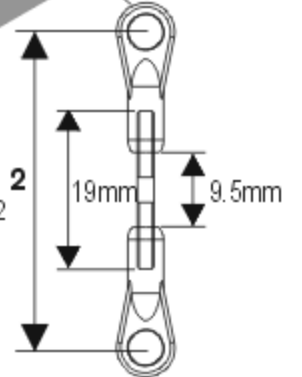

**Linkage rod(C)**  
Approx. 66mm x 2  
連桿(C)約66mm x 2

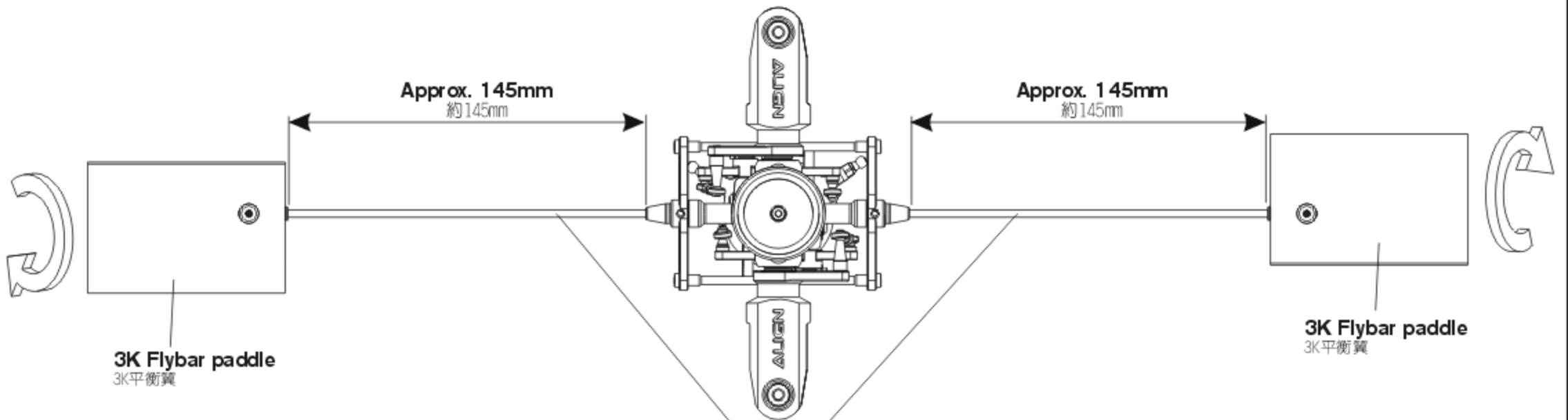
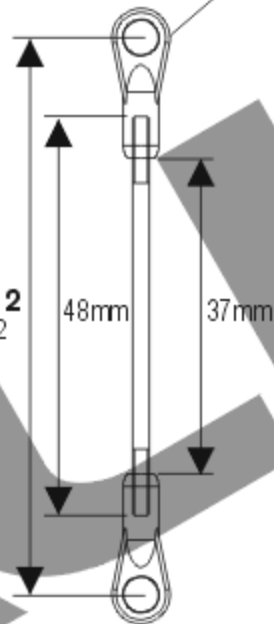

**Make sure both sides are equal in length.**  
請保持平衡桿兩邊長度相等。



# 600NB3

- Hex socket self tapping screw**  
圓頭內六角自攻螺絲(T3x7mm)x5
- One-way bearing**  
單向軸承(φ12xφ18x16mm)x1
- Washer**  
單向軸承華司(φ11.5xφ18x0.8mm)x1
- Socket collar screw**  
圓頭內六角軸套螺絲(M3x20mm)x1
- M3 Nut**  
M3防鬆螺帽x1

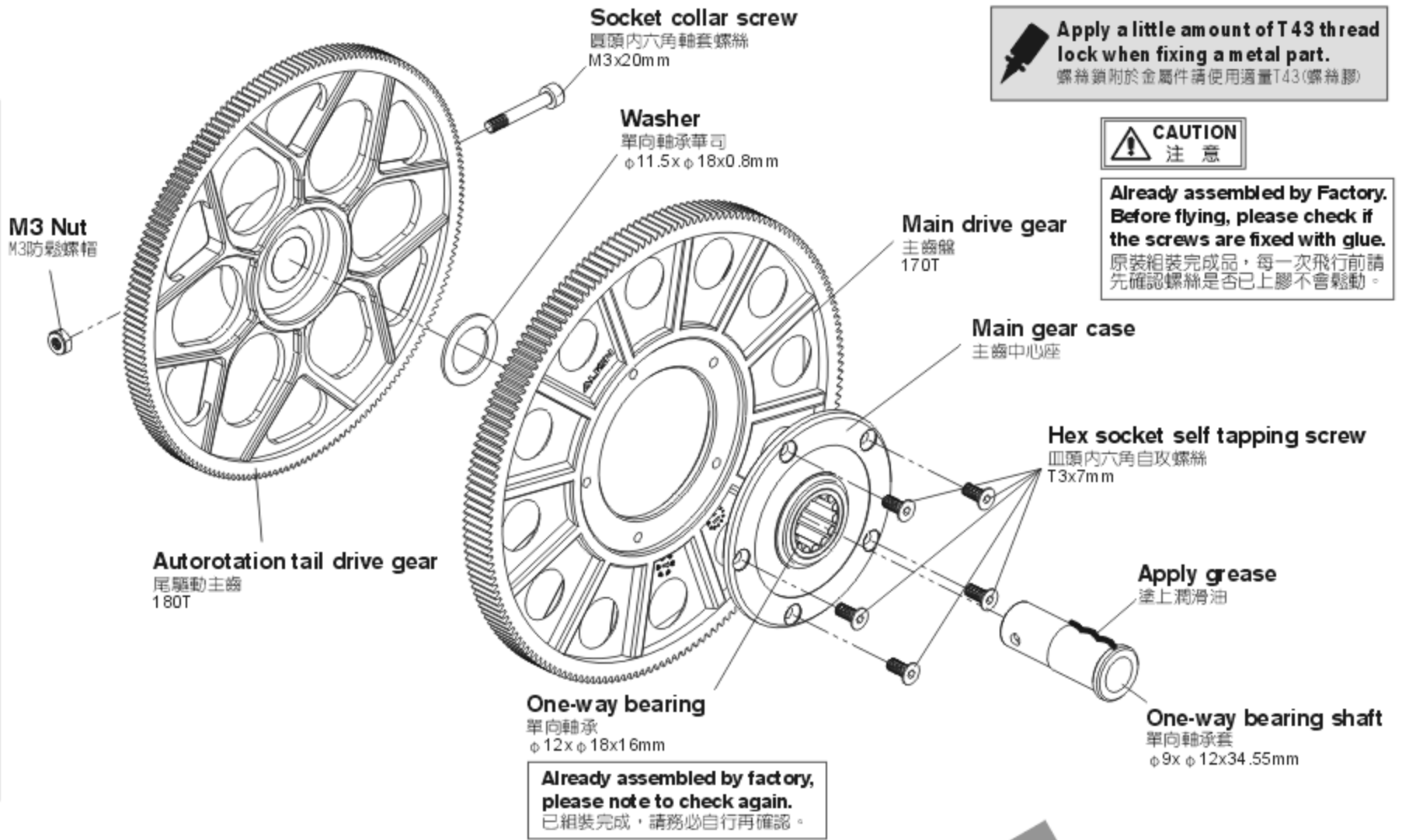

# 50HB007A

- Bearing**  
軸承(φ10xφ19x5mm)x2
- M3 Specialty washer**  
M3特殊華司(φ3xφ8x2mm)x8
- Socket screw**  
圓頭內六角螺絲(M3x10mm)x8
- Socket screw**  
圓頭內六角螺絲(M3x8mm)x2
- Socket screw**  
圓頭內六角螺絲(M2x6mm)x8

# 50HB007B

- M3 Specialty washer**  
M3特殊華司(φ3xφ8x2mm)x6
- Socket button head self tapping screw**  
半圓頭內六角自攻螺絲  
(T3x10mm)x6
- M3 Washer**  
M3華司(φ3xφ8x1mm)x2

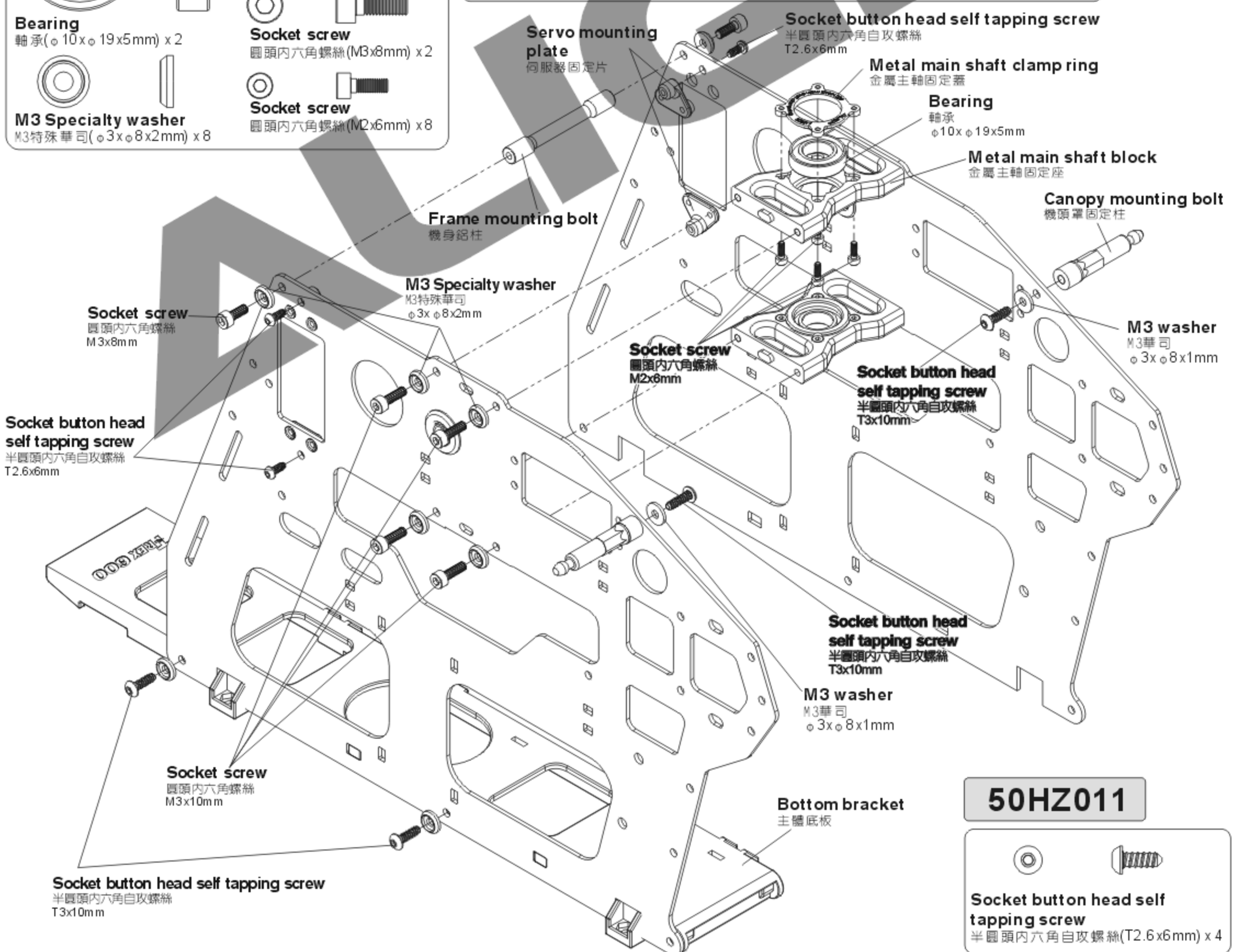

# 50HZ011

- Socket button head self tapping screw**  
半圓頭內六角自攻螺絲(T2.6x6mm)x4

**Main frame assembly point:**

First do not fully tighten the screws of main frames and put three bearings through the main shaft to check if the movements are smooth. The bottom bracket must be firmly touched the level table top (glass surface); please keep the smooth movements on main shaft and level bottom bracket, then slowly tighten the screws. This assembly can help for the power and flight performance.

機身側板組立重點：  
側板螺絲先不完全鎖緊，放入主軸貫穿三顆軸承確認上下移動必需滑順，主體底板必須與水平桌面（玻璃平面）踏實緊貼；請保持主軸滑順與底板平行桌面後慢慢鎖緊螺絲。正確側板的組裝對動力與飛行性能有顯著幫助。

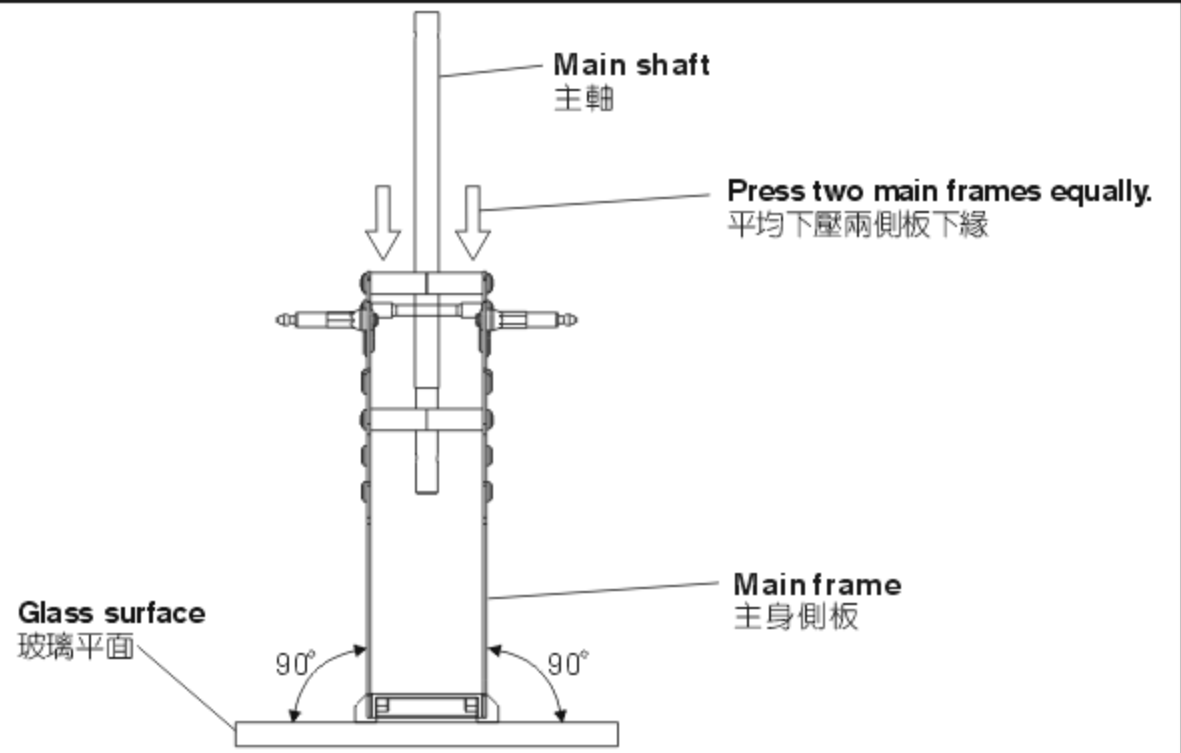

**50HB007A**

**50HB007B**

Apply a little amount of T43 thread lock when fixing a metal part.  
螺絲鎖附於金屬件請使用適量T43(螺絲膠)

**Socket screw**  
圓頭內六角螺絲(M3x6mm) x 4





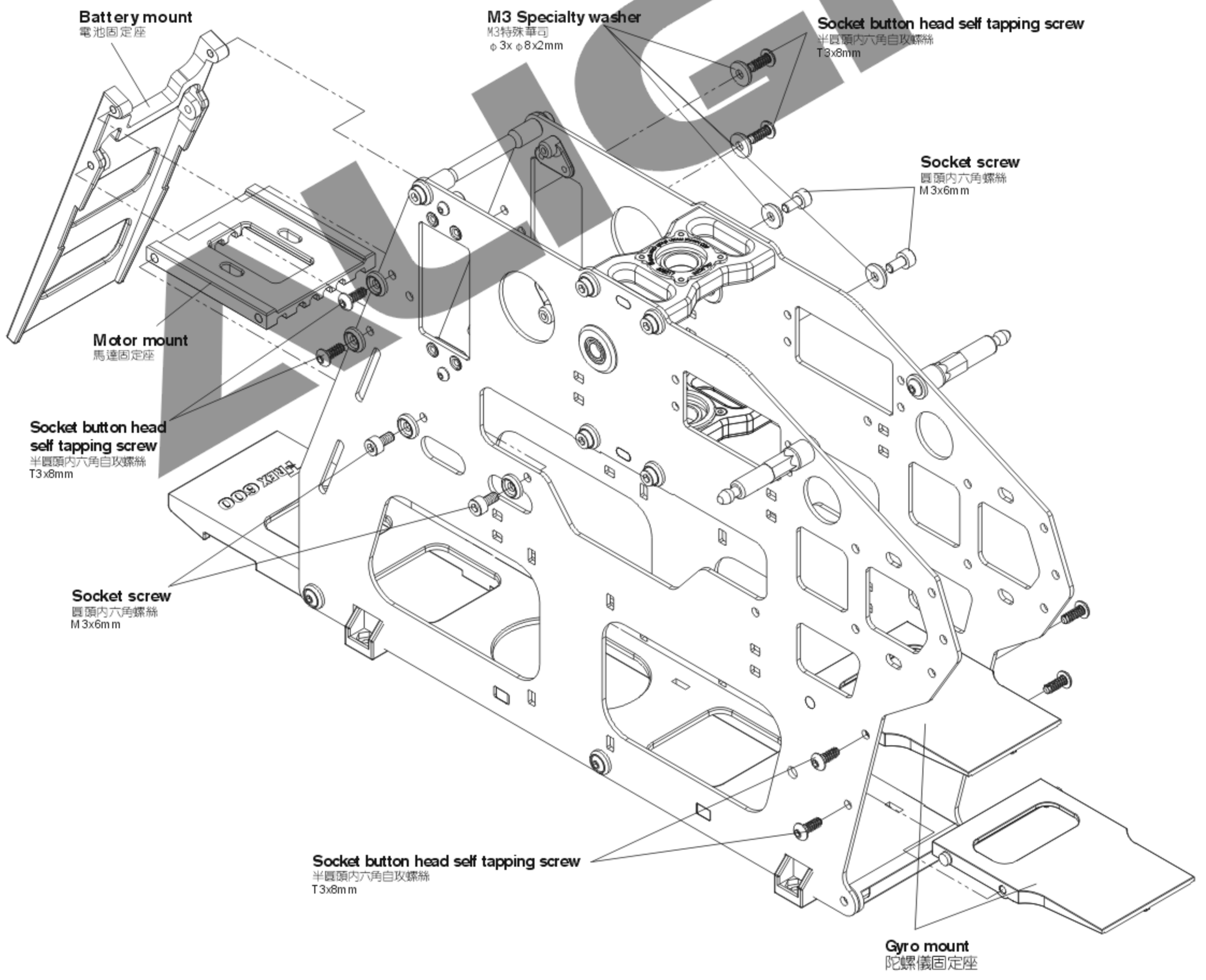

**Socket button head self tapping screw**  
半圓頭內六角自攻螺絲(T3x8mm) x 8

**M3 Specialty washer**  
M3特殊華司(φ3xφ8x2mm) x 8



# 50HB007A

# 50HB007B

 <b>Bearing</b> 軸承(φ3xφ7x3mm) x 2	 <b>Socket screw</b> 圓頭內六角螺絲(M3x6mm) x 2
 <b>Bearing</b> 軸承(φ5xφ9x3mm) x 4	 <b>M4 Set screw</b> M4止淺螺絲(M4x4mm) x 1
 <b>Socket button head screw</b> 半圓頭內六角螺絲(M3x6mm) x 2	 <b>Control shaft collar</b> 運動桿套圈(φ5xφ7x7mm) x 2

 <b>Linkage ball A(M3x4)</b> 球頭A(M3x4)(φ4.75x8.68mm) x 8	 <b>Elevator ball link</b> 升降臂連桿頭 x 1	 <b>Washer</b> 華司(φ3xφ5.5x0.3mm) x 2
 <b>Socket screw</b> 圓頭內六角螺絲(M2.5x8mm) x 1	 <b>Washer</b> 華司(φ5xφ7x0.2mm) x 2	 <b>Washer</b> 華司(φ5xφ7x0.5mm) x 2

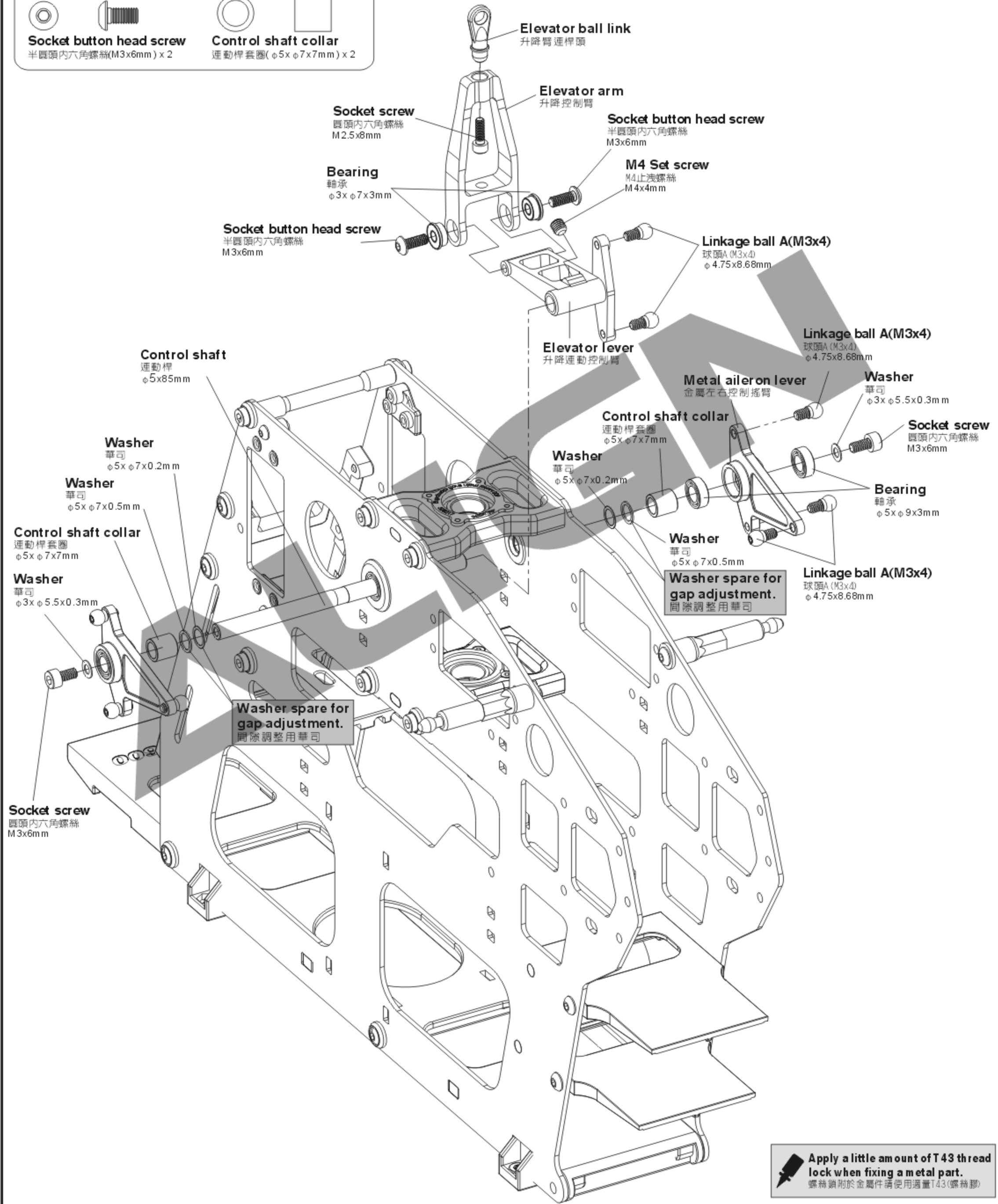

 **Apply a little amount of T43 thread lock when fixing a metal part.**  
螺絲鎖附於金屬件請使用適量T43(螺絲膠)

# 600NG2

Apply a little amount of T43 thread lock when fixing a metal part.  
 螺絲鎖附於金屬件請使用適量T43(螺絲膠)

-  **Socket screw**  
圓頭內六角螺絲(M3x12mm) x 4
-  **M3 Set screw**  
M3止洩螺絲(M3x4mm) x 4
-  **M3 Nut**  
M3防鬆螺帽 x 4
-  **M3 Washer**  
M3華司(φ3xφ8x1mm) x 4

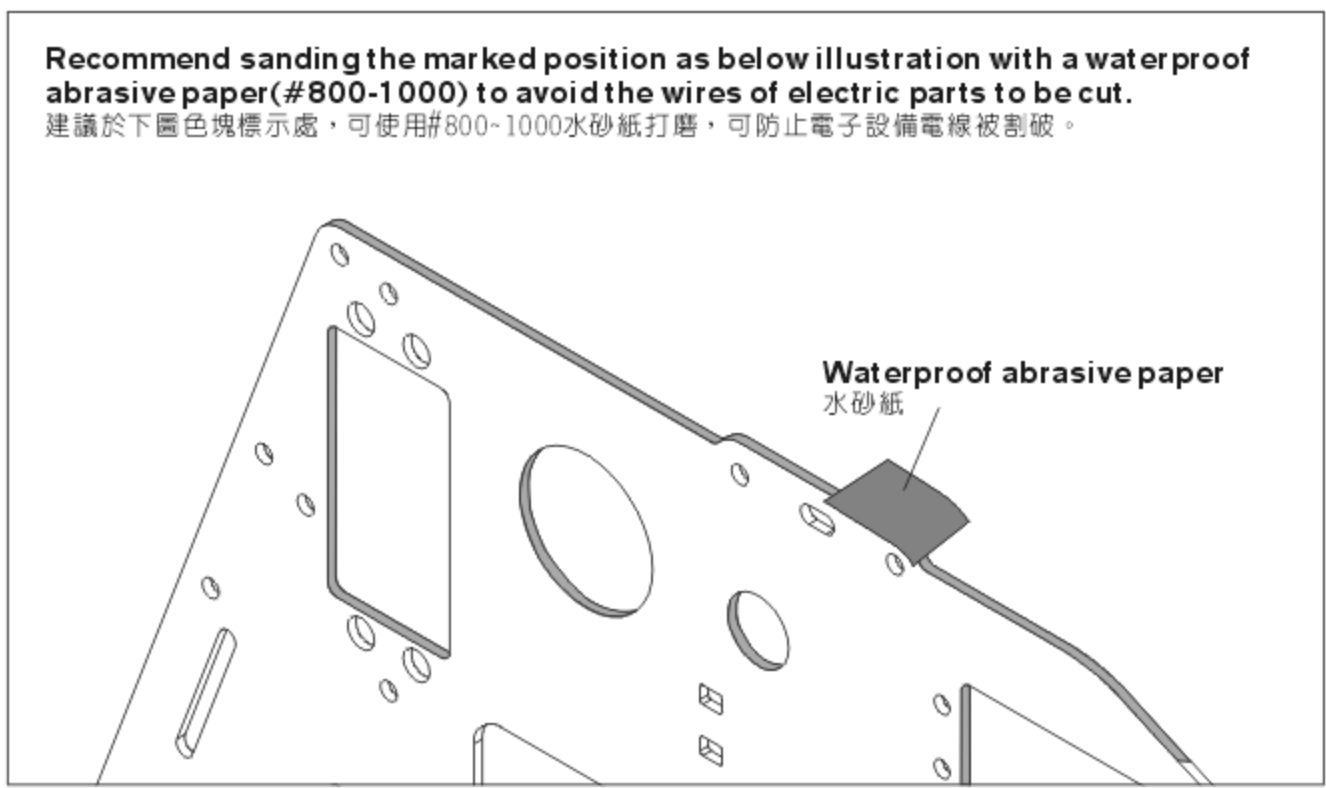
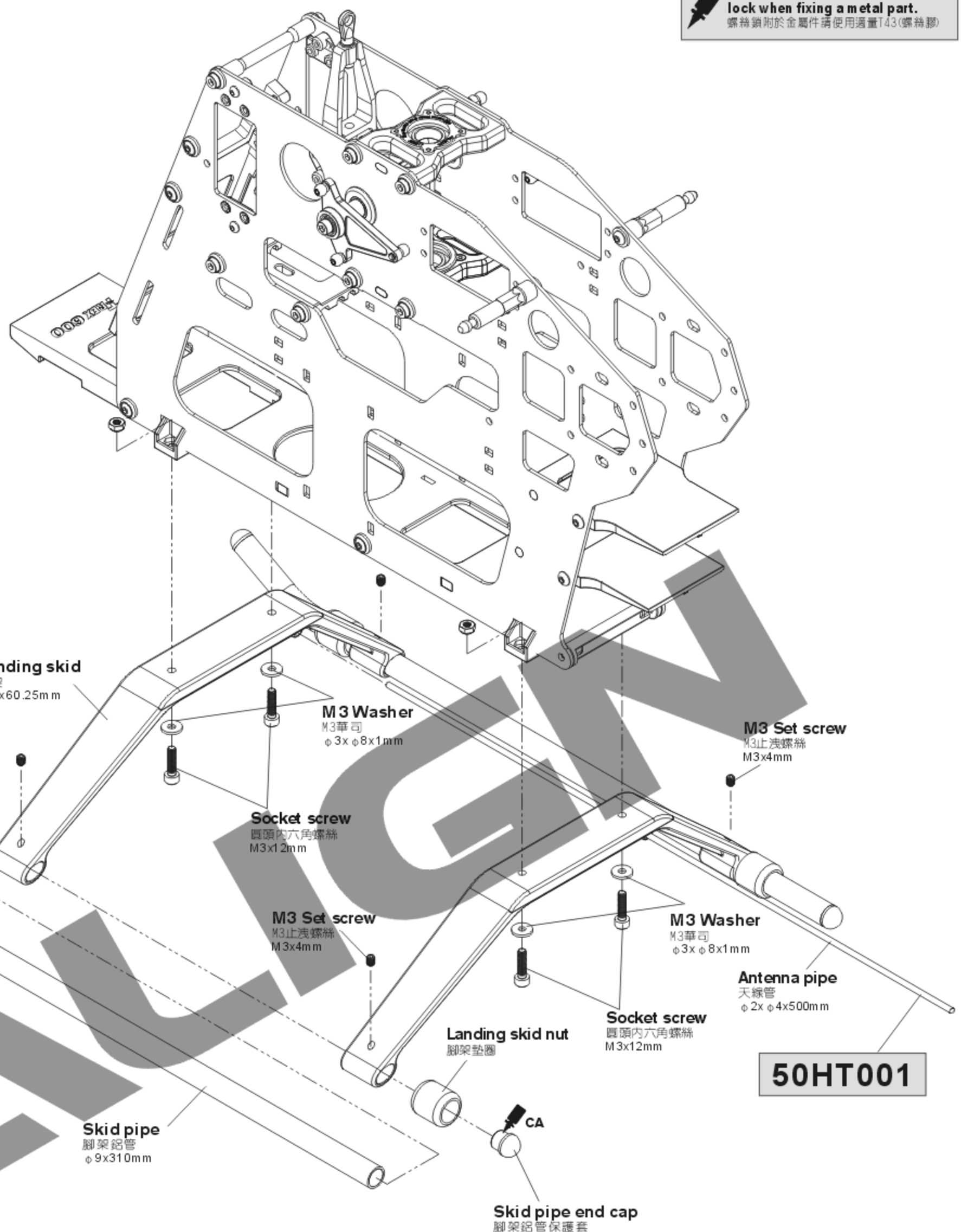

## 50HZ011

**Linkage ball A(M2x3.5)**  
球頭A(M2x3.5) (φ4.75x8.18mm) x 4

**Socket button head self tapping screw**  
半圓頭內六角自攻螺絲(T3X14mm) x 4

**M2 Nut**  
M2螺帽 x 4

## 50HB007B

**Socket button head self tapping screw**  
半圓頭內六角自攻螺絲(T2.6x8mm) x 4

**Socket button head self tapping screw**  
半圓頭內六角自攻螺絲(T2.6x14mm) x 4

### DS610 Digital Servo:

1. Stall torque/輸出扭力: 9.6kg.cm(4.8V)  
12.0kg.cm(6.0V)
2. Motion speed/動作速度: 0.10sec/60° (4.8V)  
0.08sec/60° (6.0V)
3. Dimension/尺寸: 40.3 x 20.1 x 36mm
4. Weight/重量: 52.2g

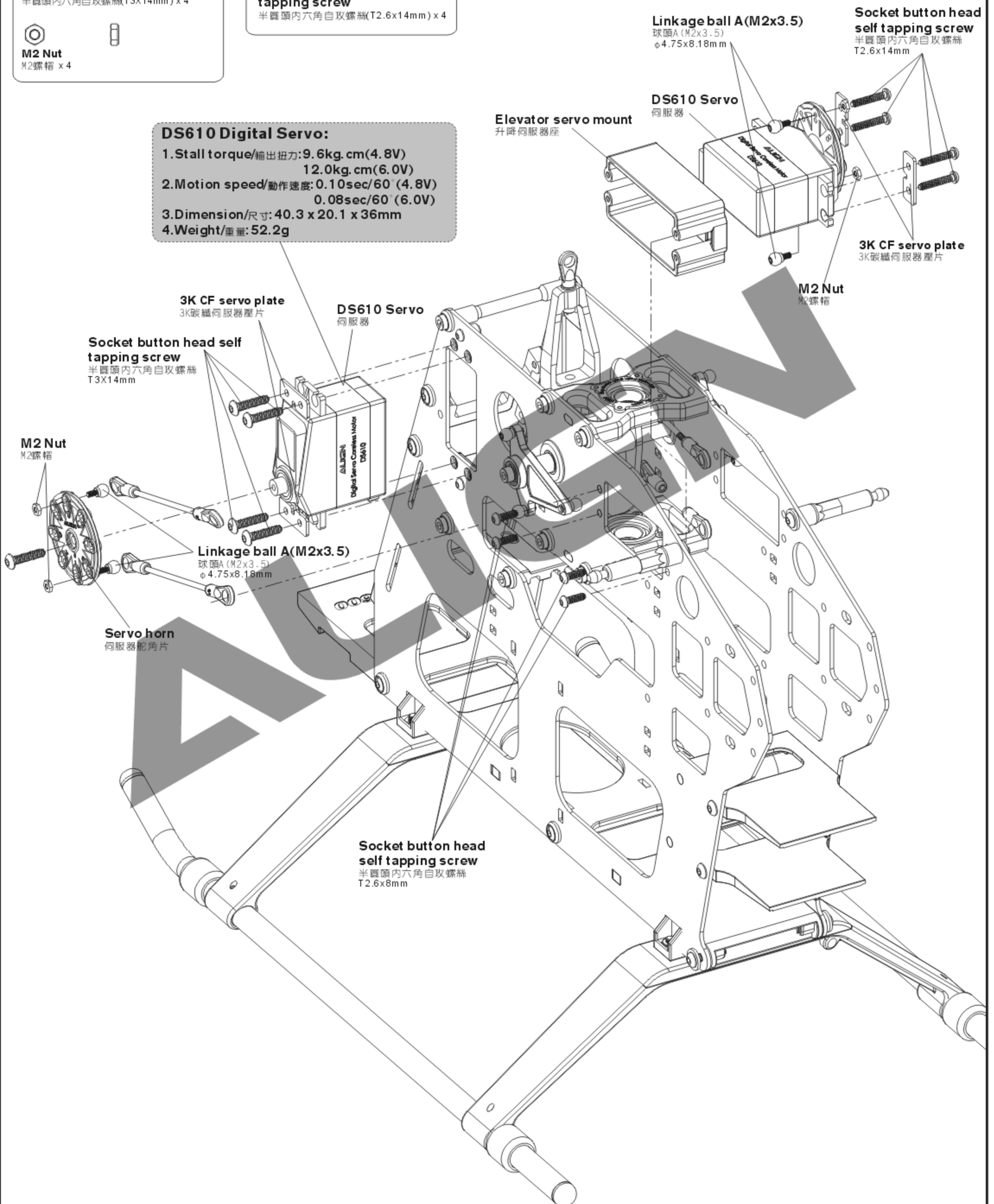

### 50HZ011

- Linkage ball A(M2x3.5)**  
球頭A (M2x3.5) (φ4.75x8.18mm) x 2
- Socket button head self tapping screw**  
半圓頭內六角自攻螺絲(T3X14mm) x 4
- M2 Nut**  
M2螺帽 x 2

### 50HZ009A

- Ball link**  
連桿頭 x 12

### 50HZ009

- Linkage rod(E)**  
連桿(E) φ1.96x32mm x 2
- Linkage rod(F)**  
連桿(F) φ1.96x50mm x 4

Linkage rod(E)  
Approx. 49mm x 2  
連桿(E)約49mm x 2

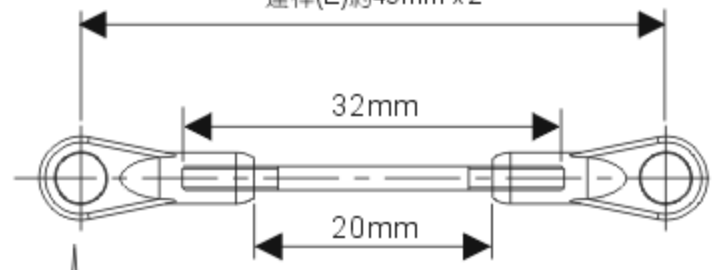

Linkage rod(F)  
Approx. 70mm x 2  
連桿(F)約70mm x 2

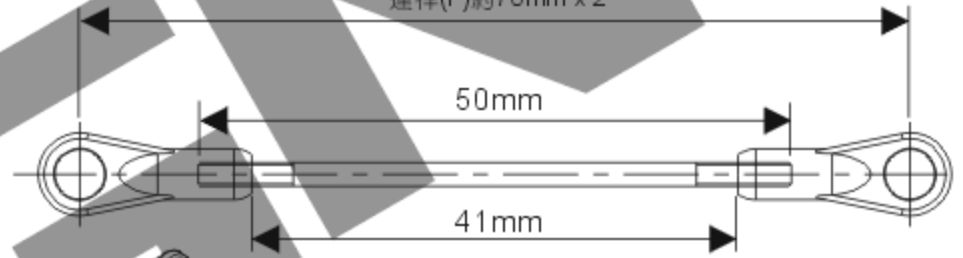

**3K CF servo plate**  
3K碳纖伺服器壓片

**Linkage ball A(M2x3.5)**  
球頭A (M2x3.5)  
φ4.75x8.18mm

**Servo horn**  
伺服器舵角片

**M2 Nut**  
M2螺帽

**Socket button head self tapping screw**  
半圓頭內六角自攻螺絲  
T3X14mm

**DS610 Servo**  
伺服器

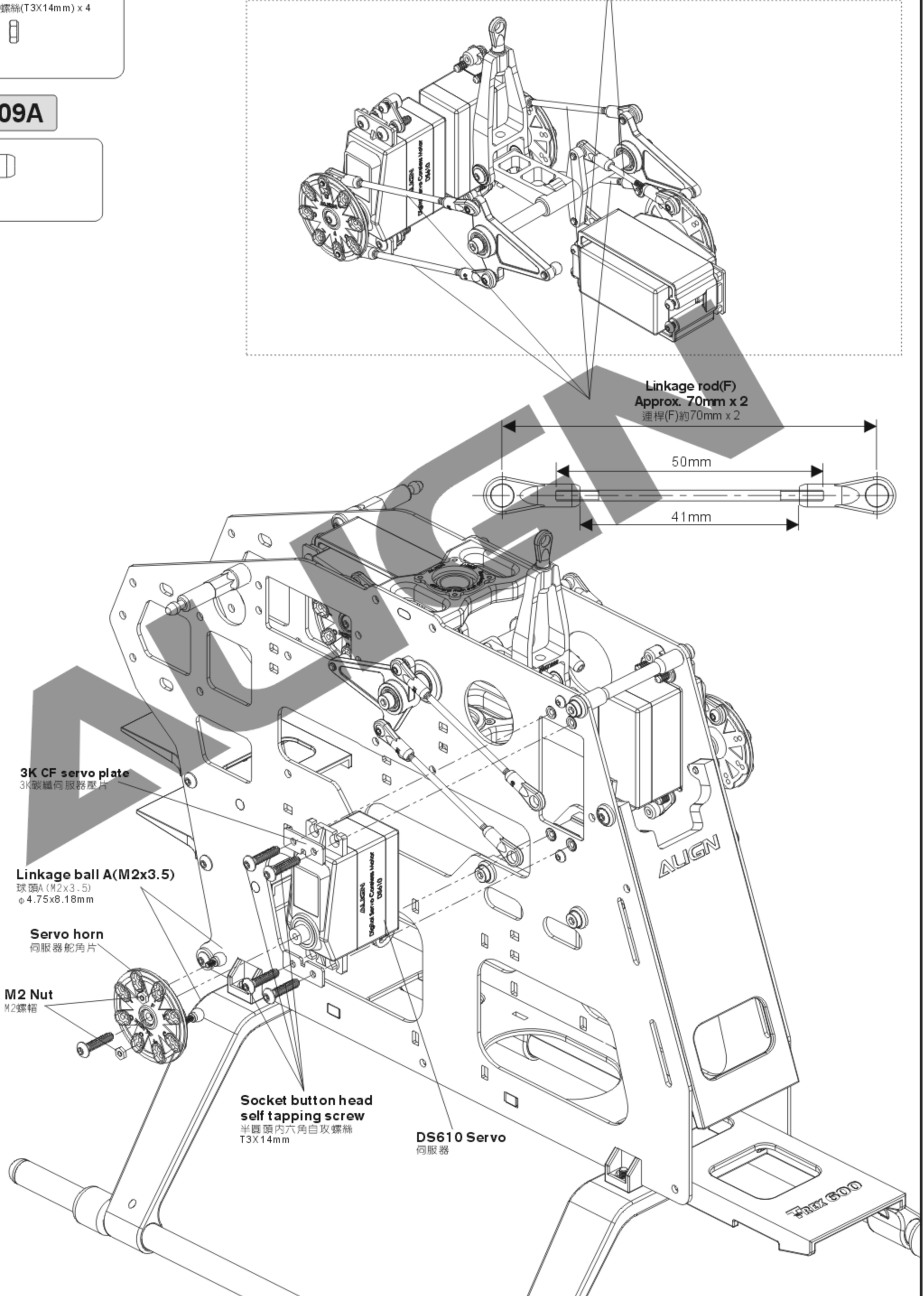

# 50HT012

**Socket button head self tapping screw**  
半圓頭內六角自攻螺絲(T2x8mm) x 2

**Bearing**  
軸承(φ4xφ9x4mm) x 2

**Bearing**  
軸承(φ12xφ18x4mm) x 2

**CAUTION**  
注意  
Already assembled by Factory.  
Before flying, please check if the screws are fixed with glue.  
原裝相裝完成品，每一次飛行前請先確認螺絲是否已上膠不會鬆動。

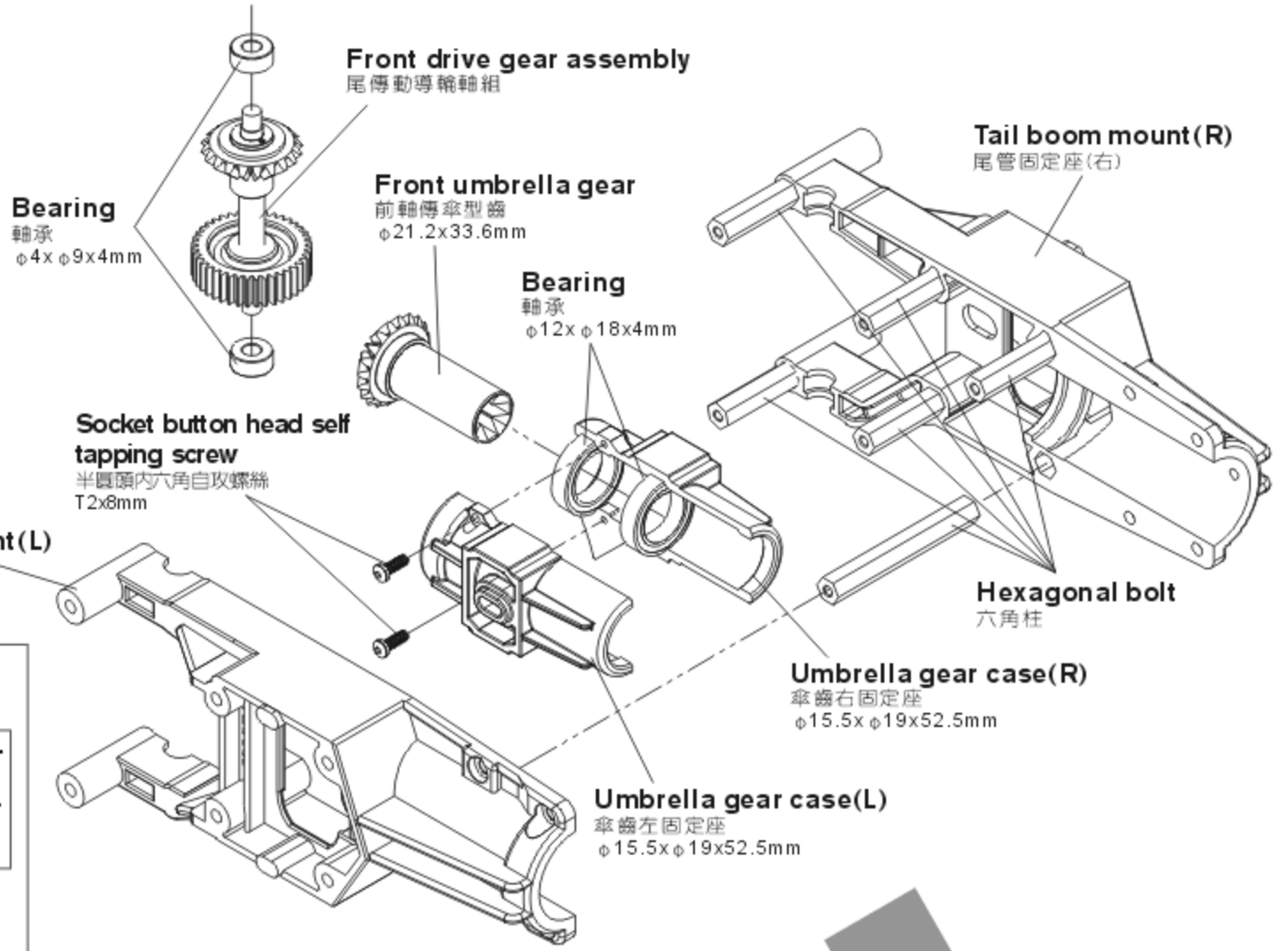

# 600NT2A

**Socket button head screw**  
半圓頭內六角螺絲(M3x6mm) x 6

**Socket screw**  
圓頭內六角螺絲(M3x10mm) x 2

**Socket screw**  
圓頭內六角螺絲(M3x8mm) x 1

**Socket screw**  
圓頭內六角螺絲(M2x5mm) x 2

**M3 Specialty washer**  
M3特殊華司(φ3xφ8x2mm) x 2

**Bearing**  
軸承(φ5xφ10x5mm) x 2

**Socket screw**  
圓頭內六角螺絲 M3x10mm

**M3 Specialty washer**  
M3特殊華司 φ3xφ8x2mm

**3K CF Vertical stabilizer**  
3K 碳纖垂直翼

**Metal tail unit**  
金屬尾軸傳固定座 φ18xφ23.6x53mm

**Socket screw**  
圓頭內六角螺絲 M3x8mm

**Metal plate (R)**  
金屬尾軸傳座右側板 39.5x25x5mm

**Socket button head screw**  
半圓頭內六角螺絲 M3x6mm

**Socket screw**  
圓頭內六角螺絲 M2x5mm

**Control arm mounting bolt**  
軸傳尾控制臂固定座 15x7x11.6mm

**Tail rotor shaft assembly**  
軸傳尾橫軸組

**Aluminum bolt**  
金屬尾齒箱鋁柱 φ4.98x24mm

**Socket button head screw**  
半圓頭內六角螺絲 M3x6mm

**Metal plate (L)**  
金屬尾軸傳座左側板 39.5x25x9.3mm

# 600NT2J

**Apply a little amount of T43 thread lock when fixing a metal part.**  
螺絲鎖附於金屬件請使用適量T43 (螺絲膠)

### 600NT2B

- Socket screw**  
圓頭內六角螺絲(M3x8mm) x 2
- Thrust bearing**  
止推軸承(φ5xφ10x4mm) x 2
- Bearing**  
軸承(φ5xφ10x4mm) x 2
- Washer**  
華司(φ3xφ8x0.6mm) x 2
- M4 Set screw**  
M4止洩螺絲(M4x4mm) x 1

### 600NT2C

- Linkage ball A(T2.6x3.5)**  
球頭A(T2.6x3.5)(φ4.75x8.18mm) x 1
- Socket collar screw**  
圓頭內六角軸套螺絲(M3x15mm) x 1
- Washer**  
華司(φ3xφ4.8x0.3mm) x 2
- Bearing**  
軸承(φ3xφ6x2.5mm) x 2
- Collar**  
尾旋翼控制臂鋁套(φ3xφ4.9x5mm) x 1

### 600NT2I

- Collar screw**  
軸套螺絲(M2x8mm) x 4
- Collar A**  
尾連桿頭鋼套A(φ2xφ3x4mm) x 2
- Collar B**  
尾連桿頭鋼套B(φ2xφ3x3mm) x 2
- Linkage ball A(T2.6x3.5)**  
球頭A(T2.6x3.5)(φ4.75x8.18mm) x 1
- Bearing**  
軸承(φ6xφ10x3mm) x 2
- Slide shaft**  
尾軸滑套 x 1
- Collar**  
尾控制組軸套座鋁襯墊 x 1

Apply a little amount of T43 thread lock when fixing a metal part.  
螺絲鎖附於金屬件請使用適量T43(螺絲膠)

**CAUTION**  
注意

Aim tail rotor hub at the concave of tail rotor shaft and fix it, please apply a little glue on the set screw.  
尾旋翼T型座瞄準尾橫軸的凹刻並鎖上，請確認止洩螺絲上膠。

**CAUTION**  
注意

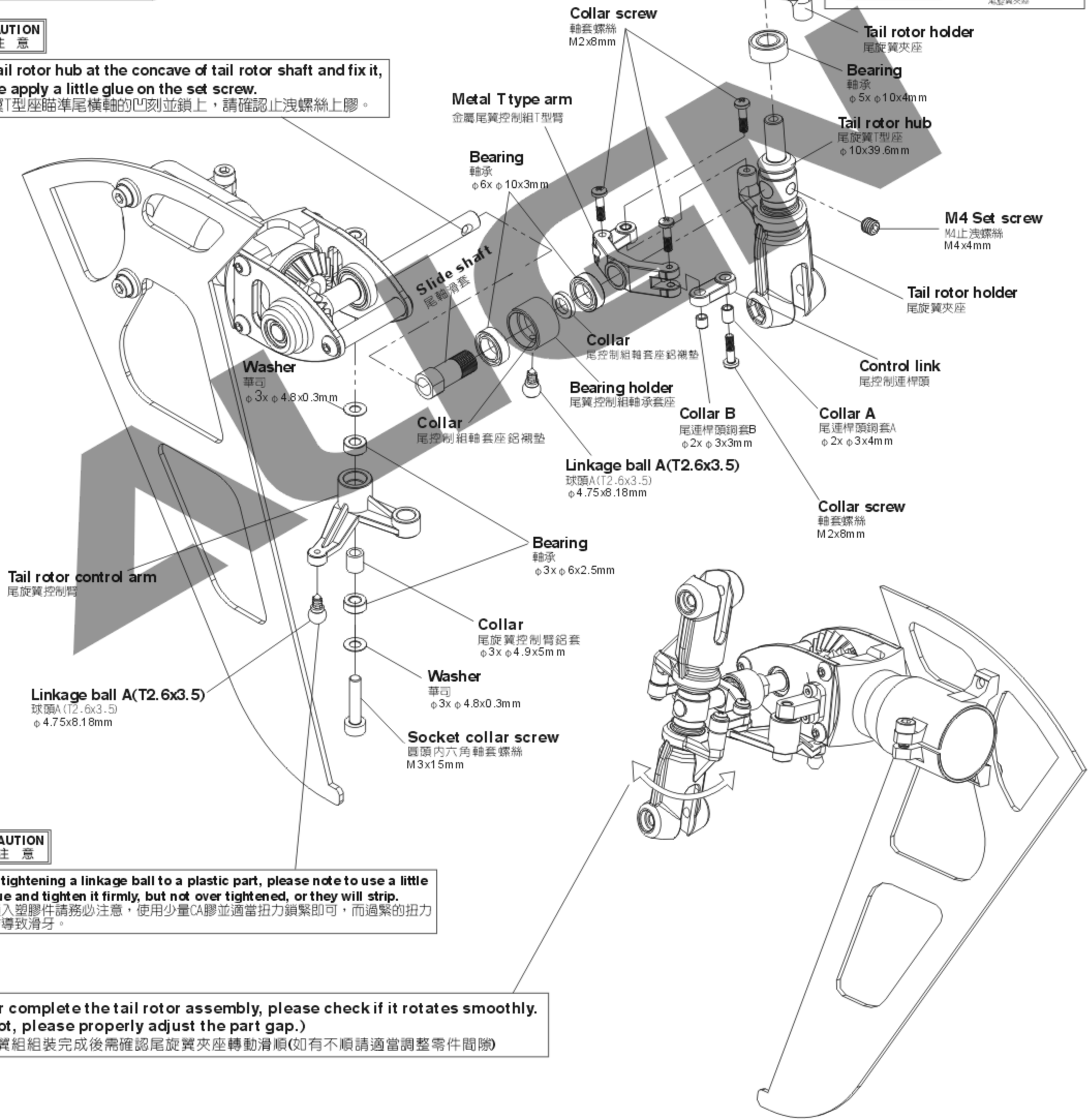
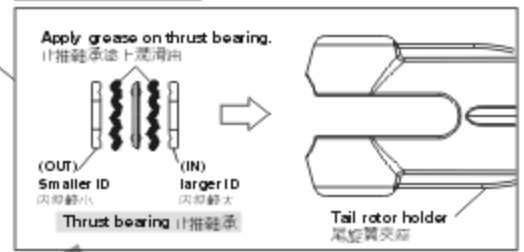

**CAUTION**  
注意

When tightening a linkage ball to a plastic part, please note to use a little CA glue and tighten it firmly, but not over tightened, or they will strip.  
球頭鎖入塑膠件請務必注意，使用少量CA膠並適當扭力鎖緊即可，而過緊的扭力可能會導致滑牙。

After complete the tail rotor assembly, please check if it rotates smoothly. (If not, please properly adjust the part gap.)  
尾旋翼組裝完成後需確認尾旋翼夾座轉動滑順(如有不順請適當調整零件間隙)



# 600NT2B

- Socket collar screw  
圓頭內六角軸套螺絲(M3x20mm) x 2
- M3 Nut  
M3防鬆螺帽 x 2

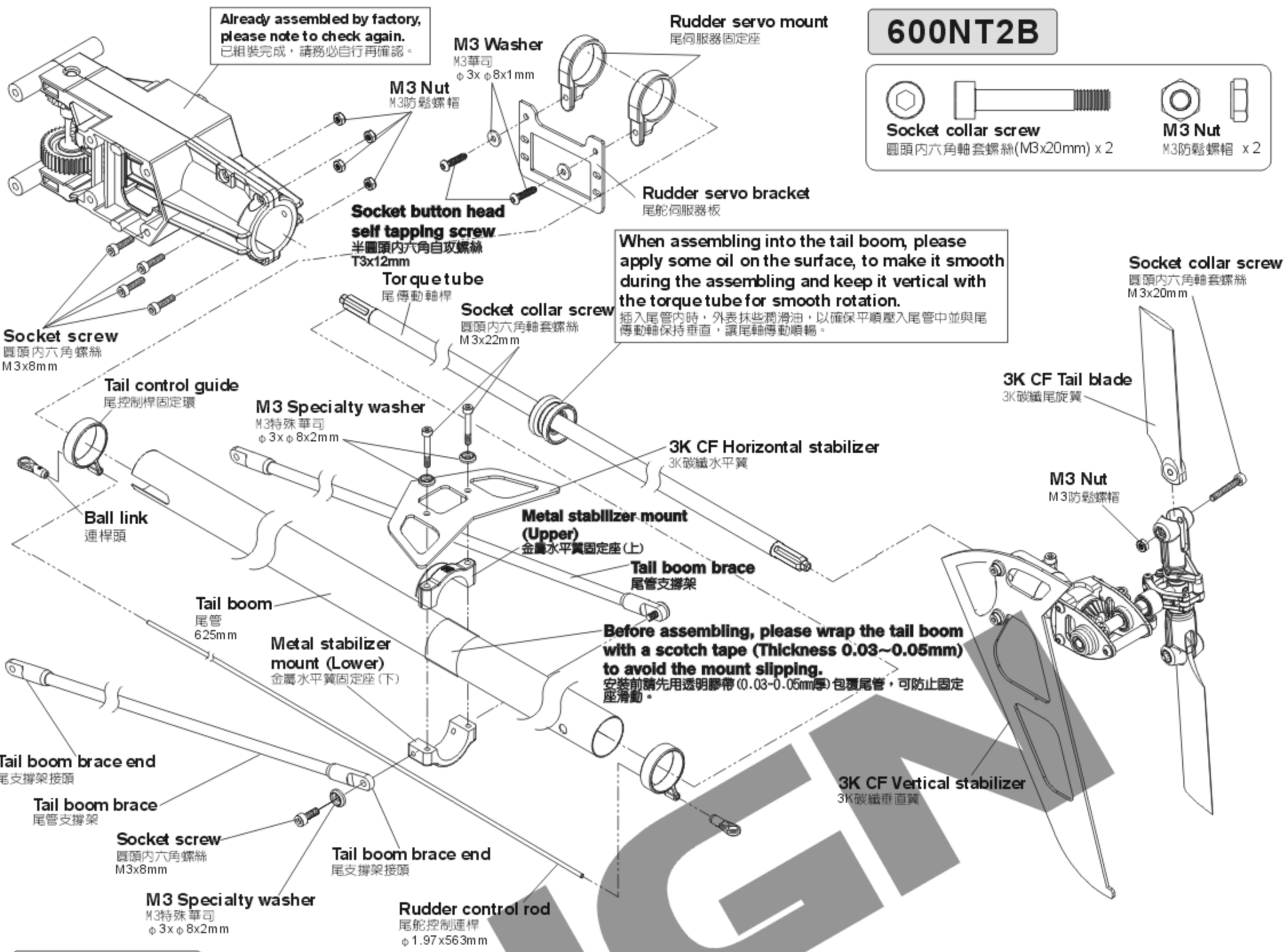

## 50HT003

- Socket button head self tapping screw  
半圓頭內六角自攻螺絲(T3x12mm) x 2
- M3 Washer  
M3華司(φ3xφ8x1mm) x 2

## 50HT012A

- Socket screw  
圓頭內六角螺絲(M3x8mm) x 4
- M3 Nut  
M3防鬆螺帽 x 4

## 600NT2LA

- Socket collar screw  
圓頭內六角軸套螺絲(M3x22mm) x 2
- Socket screw  
圓頭內六角螺絲(M3x8mm) x 2
- M3 Specialty washer  
M3特殊華司(φ3xφ8x2mm) x 4

### Tip to fix the torque tube 傳動軸軸承固定位置要領

Please apply some CA glue to fix bearing on the torque tube, avoid CA glue adhering to the dust cover or it may cause the bearing stuck. When assembling into the tail boom, please apply some oil on the bearing holding and press the holder into the tail boom horizontally. 請以少量CA將軸承固定於尾傳動軸上，避免CA沾到軸承的防塵蓋而導致軸承卡死，插入尾管內時，尾傳動軸承墊圈外表抹些潤滑油，將尾傳動軸承墊圈平行壓入尾管中不可歪斜。

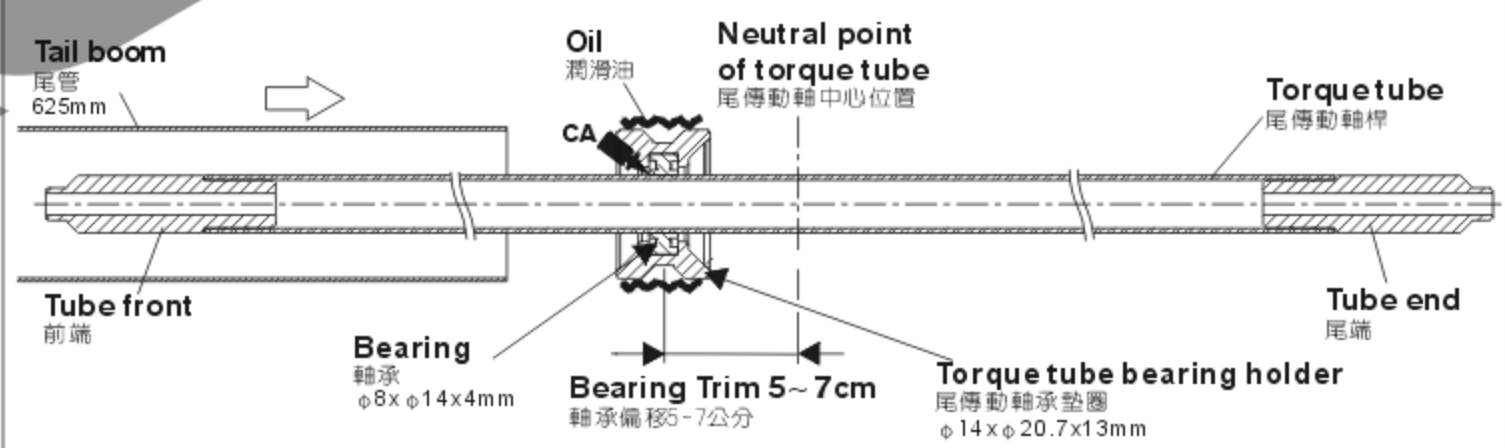

Apply a little amount of T43 thread lock when fixing a metal part.  
螺絲鎖附於金屬件請使用適量T43(螺絲膠)

## 50HT012A

## 50HT008

Apply a little amount of T43 thread lock when fixing a metal part.  
螺絲鎖附於金屬件請使用適量T43(螺絲膠)



Please assemble the F linkage rods inside the servo horns to avoid any interference caused by the canopy.  
F連桿請裝於伺服臂內側確保動作時不碰觸機頭罩

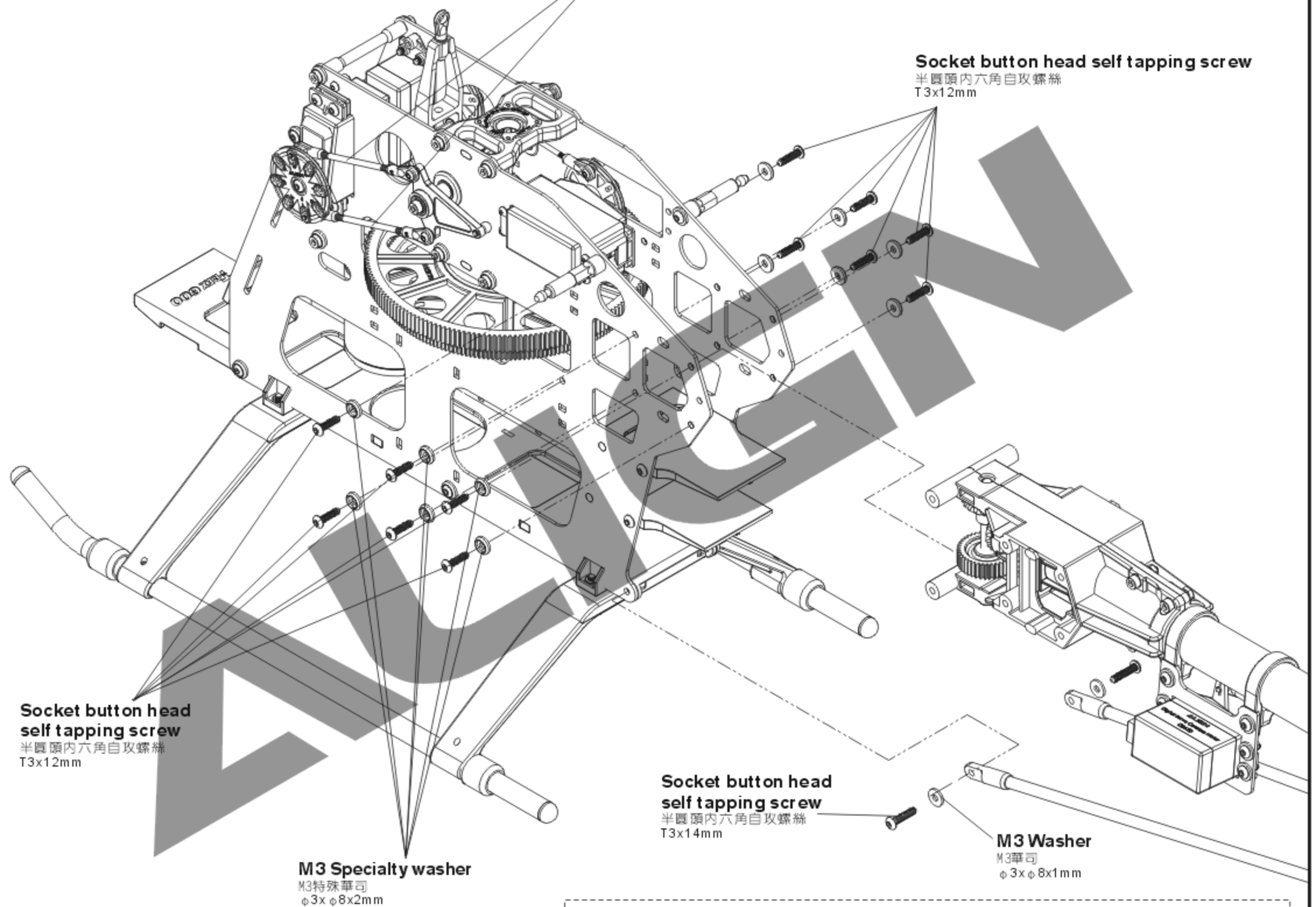

**DS620 Digital Servo:**

1. 1520 μs standard band / 1520 μs 寬頻系統
2. Stall torque / 輸出扭力: 8.0kg.cm (4.8V) / 10.0kg.cm (6.0V)
3. Motion speed / 動作速度: 0.09sec/60 (4.8V) / 0.07sec/60 (6.0V)
4. Dimension / 尺寸: 40.3 x 20.1 x 36mm
5. Weight / 重量: 52.2g

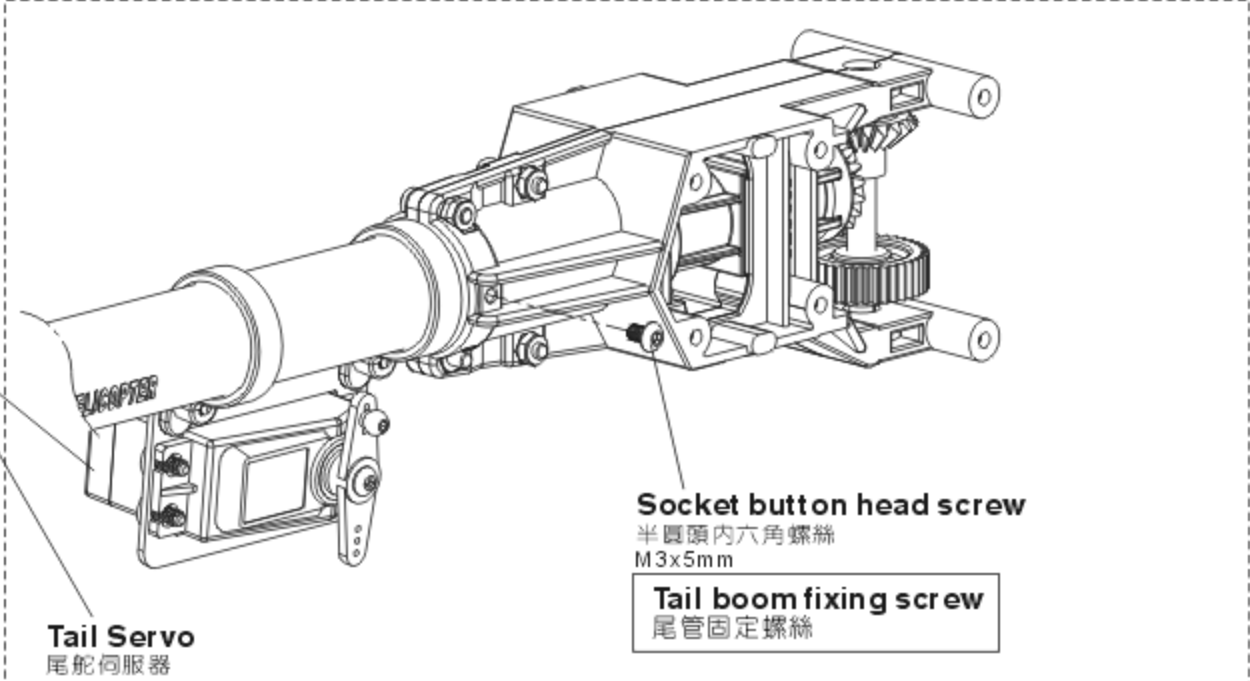

When tightening a screw to a plastic part, please tighten it firmly, but not over tightened, or they will strip.  
螺絲鎖入塑膠件請務必注意，適當扭力鎖緊即可，而過緊的扭力可能會導致滑牙。

# 600NB3



Socket collar screw  
圓頭內六角軸套螺絲 (M3x20mm)x1



M3 Nut  
M3防鬆螺帽 x1

# 50HH008



M4 Set screw  
M4止洩螺絲 (M4x4mm)x2

# 50HZ009

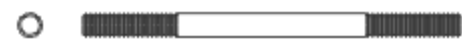

Linkage rod(D)  
連桿 (D)  $\phi$  1.96x39.5mm x 2

# 50HZ009A



Ball link  
連桿頭 x 4

# 50HZ012



Socket screw  
圓頭內六角螺絲 (M3x10mm) x 2



M3 Washer  
M3華司 ( $\phi$  3x $\phi$  8x1mm) x 2

# Main drive gear set

主齒輪組

Socket collar screw  
圓頭內六角軸套螺絲  
M3x20mm

M3 Nut  
M3防鬆螺帽

When tightening the main blade fixing screw, please tighten it firmly, but not over tighten, or it may cause the damage of main blade holder and result in danger.

鎖緊主旋翼螺絲須注意適當緊度即可，過緊可能導致主旋翼夾座受損，飛行意外發生。

Socket collar screw  
圓頭內六角軸套螺絲  
M4x27mm

M4 Nut  
M4防鬆螺帽

600 Blade  
600主旋翼

Socket screw  
圓頭內六角螺絲  
M3x10mm

For motor fixing  
馬達固定螺絲

Lock collar  
主軸固定環  
 $\phi$  10x $\phi$  15x7mm

M3 Washer  
M3華司  
 $\phi$  3x $\phi$  8x1mm

T43

T43

M4 Set screw  
M4止洩螺絲  
M4x4mm

Linkage rod(D)  
Approx. 60.5mm x 2  
連桿(D)約60.5mm x 2

39.5mm

31.5mm

# 50HZ012

Motor  
馬達  
1220KV

Motor pinion gear 14T  
14T馬達齒輪

M4 Set screw  
M4止洩螺絲  
M4x4mm

When fixing the screw of pinion gear, please aim at the fixing point on motor shaft.  
銅齒固定螺絲鎖緊時，請對準馬達心軸固定槽。

Operating Voltage/使用電壓:

DC 22.2V 6S 4000~5200mAh/16C Li-poly Battery

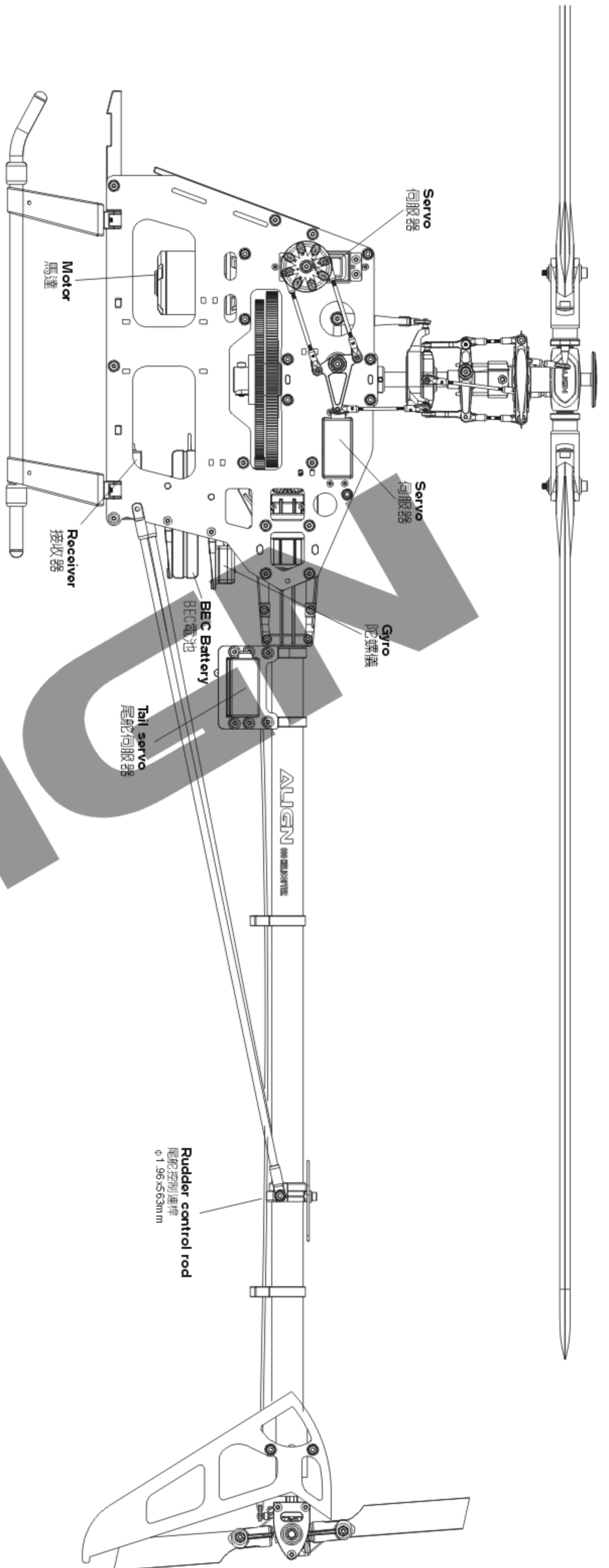

**HITEC、FUTABA 6CH receiver wiring**  
HITEC、FUTABA 6CH接收器接線示意圖

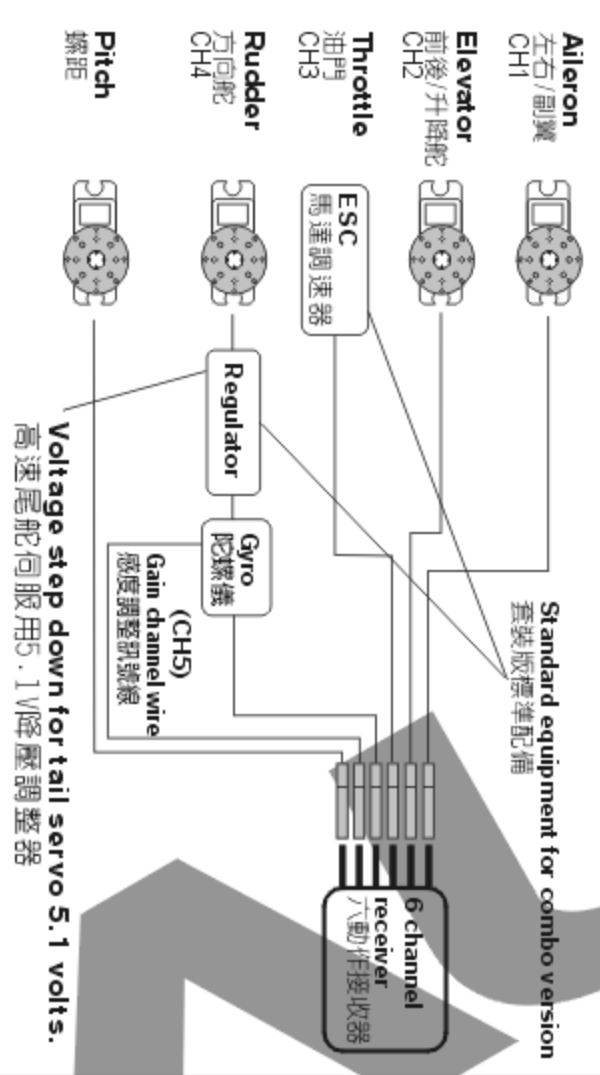

6-Channel Receiver is adequate for the requirements of the T-REX heli. You will need the following channels at a minimum: Throttle, Rudder, Elevator, Aileron, and especially Pitch(CH6) and Gyro(CH5) controls. 六動作的接收器已足夠應對T-REX遙控直升機的需求，除了油門、方向舵、升降舵、副翼等基本動作外，亦可以對應具備感度調整訊號線的陀螺儀(CH5)與螺距(CH6)。

**JR 7CH receiver wiring**  
JR 7CH接收器接線示意圖

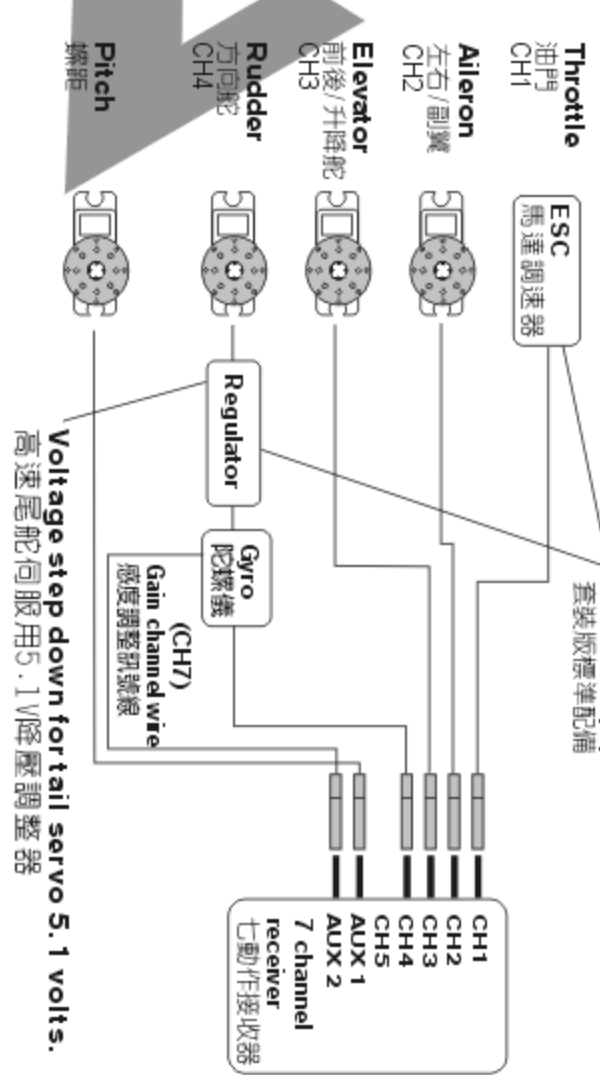

7-Channel Receiver is adequate for the requirements of the T-REX heli. You will need the following channels at a minimum: Throttle, Rudder, Elevator, Aileron, and especially Pitch(AUX 1) and Gyro(AUX 2) controls. 七動作的接收器已足夠應對T-REX遙控直升機的需求，除了油門、方向舵、升降舵、副翼等基本動作外，亦可以對應具備感度調整訊號線的陀螺儀(AUX 2)與螺距(AUX 1)。

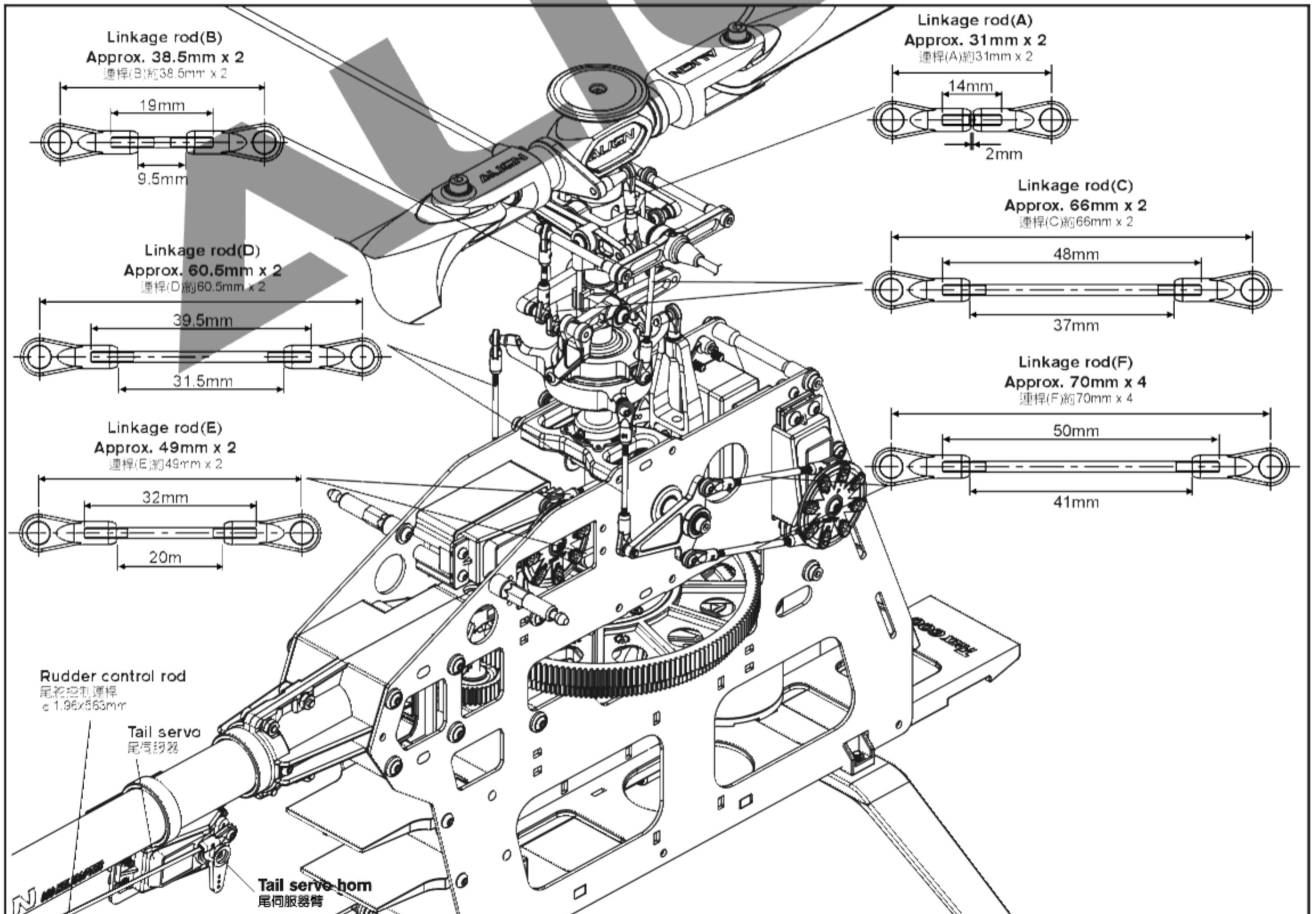
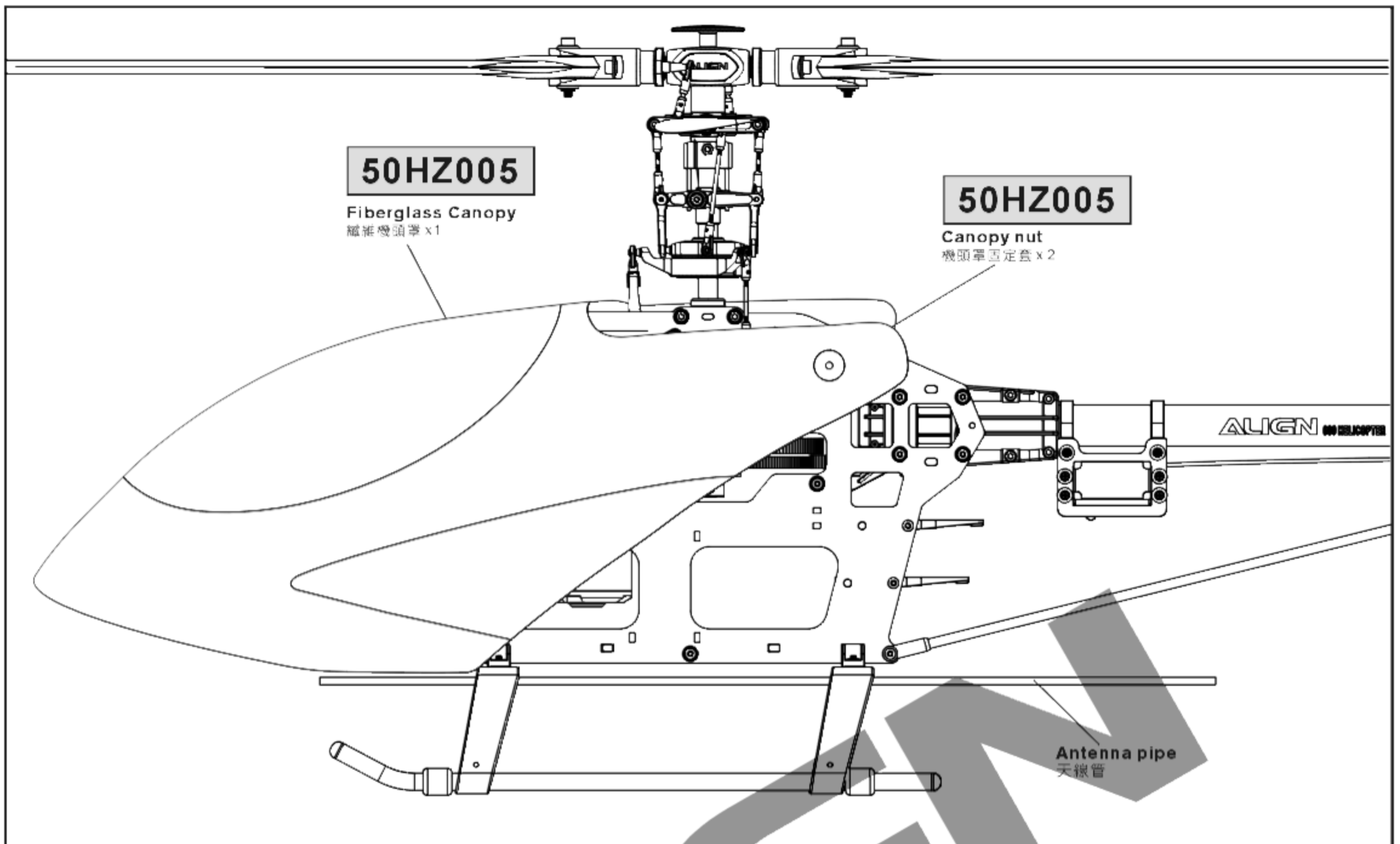

To set this option is to turn on the transmitter and connect to BEC power.

此項設定只要開啓發射器，接上BEC電源即可進行操作。

**JR Transmitter/Servo**  
JR遙控器對應伺服器關係

Aileron:CH2 副翼:CH2  
Pitch:CH6 螺距:CH6

Pitch:CH6 螺距:CH6  
Aileron:CH2 副翼:CH2

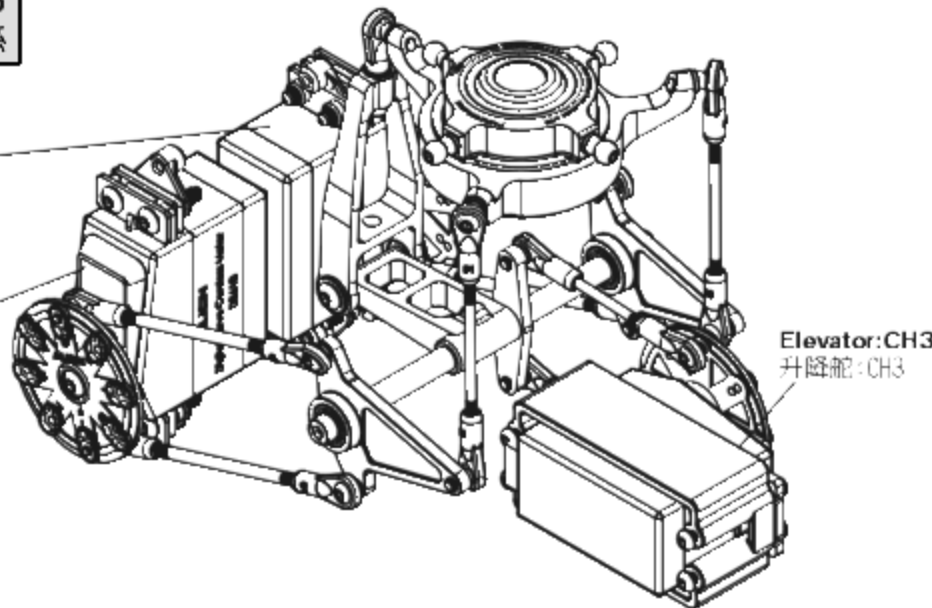

Positions of CH2 · CH6 are exchangeable, After assembling as photo (Note:Set the transmitter under CCPM 120 degrees mode), pull throttle stick (pitch) upward. If one swashplate servo (or two servos) moves downward, adjust reverse switch (REV) on the transmitter to make it moves upward. If three servo move downward, adjust the travel value (+) of SWASH CH6 on the transmitter to make them move upward. When the actions of Aileron and Elevator are opposite, adjust travel values of SWASH CH2 and CH3.

CH2、CH6可互換配置，依圖連結後(注意:遙控器須設定於CCPM 120°十字盤模式)，將油門搖桿(Pitch)往上推，若十字盤伺服器有1個或2個往下移時，請調整遙控器的反轉開關(REV)使伺服器往上，若3個伺服器同時往下移時，請調整遙控器 SWASH CH6 行程量的正負值，使伺服器同時往上平移，副翼與前後動作相反時，同樣調整 SWASH CH2、CH3 行程量正負值。

**FUTABA/HITEC Transmitter/Servo**  
FUTABA/HITEC遙控器對應伺服器關係

Aileron:CH1 副翼:CH1  
Pitch:CH6 螺距:CH6

Pitch:CH6 螺距:CH6  
Aileron:CH1 副翼:CH1

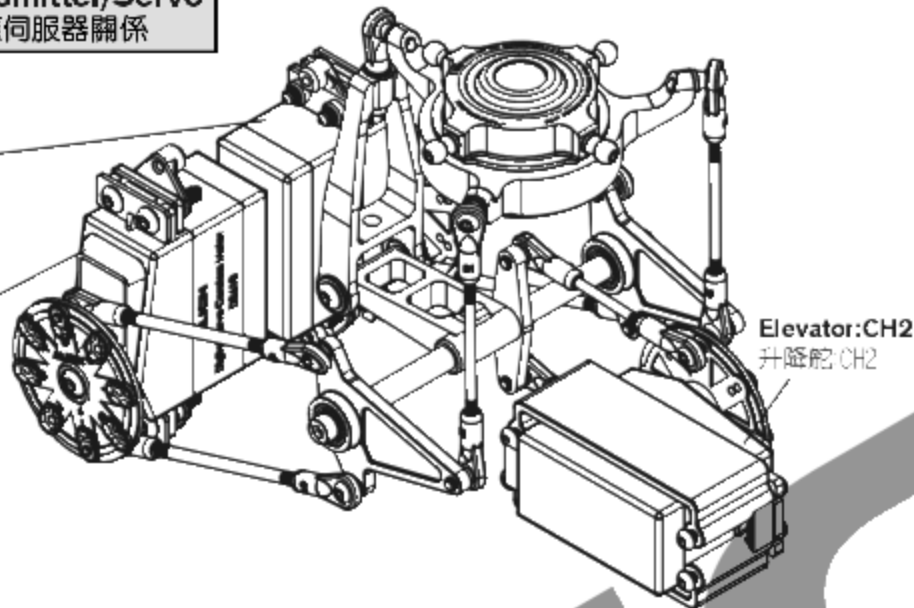

Positions of CH1 · CH6 are exchangeable, After assembling as photo (Note:Set the transmitter under CCPM 120 degrees mode), pull throttle stick (pitch) upward. If one swashplate servo (or two servos) moves downward, adjust reverse switch (REV) on the transmitter to make it moves upward. If three servo move downward, adjust the travel value (+) of SWASH CH6 on the transmitter to make them move upward. When the actions of Aileron and Elevator are opposite, adjust travel values of SWASH CH1 and CH2.

CH1、CH6可互換配置，依圖連結後(注意:遙控器須設定於CCPM 120°十字盤模式)，將油門搖桿(Pitch)往上推，若十字盤伺服器有1個或2個往下移時，請調整遙控器的反轉開關(REV)使伺服器往上，若3個伺服器同時往下移時，請調整遙控器 SWASH CH6 行程量的正負值，使伺服器同時往上平移，副翼與前後動作相反時，同樣調整 SWASH CH1、CH2 行程量正負值。

9.ADJUSTMENTS FOR GYRO AND TAIL NEUTRAL SETTING 陀螺儀與尾翼中立點設定調整

Recommend to choose Head Lock type for Gyro and turn off Revolution mixing(RVMX) mode on the transmitter, then set the gain switch on the transmitter and the gyro to Head lock mode. The gain setting is about 70%, and after transmitter setting, connect to BEC power to work on tail neutral setting. Note: When turn on BEC power, please do not touch tail rudder stick and the helicopter. Then wait for 3 seconds, make tail servo arm and tail servo at a right angle(90 degrees), tail pitch assembly must be correctly fixed about in the middle of the travel of tail rotor shaft for standard neutral setting.

陀螺儀選擇，建議選用鎖定式陀螺儀，其發射器內陀螺儀設定請關閉根軸混控模式，並將發射器上的感度開關與陀螺儀切至鎖定模式，感度設約 70% 左右，發射器設定完成後接上BEC接收電源，即可進行尾中立點設置。注意:當啟動BEC電源時請勿撥動尾舵搖桿或碰觸機體，待3秒陀螺儀鎖定後尾伺服器需與尾伺服器約成 90°，尾旋翼控制組須正確置於尾橫軸行程約中間位置，即為標準尾中立點設定。

**TAIL NEUTRAL SETTING 尾中立點設定**

After setting Head Lock mode, correct setting position of tail servo and tail pitch assembly is as photo. If the tail pitch assembly is not at the neutral position, please adjust the length of rudder control rod to trim.

陀螺儀鎖定後尾伺服器與尾 Pitch 控制組正確擺置位置。若尾 Pitch 控制組未置中時請調整尾控制連桿的長度來修正。

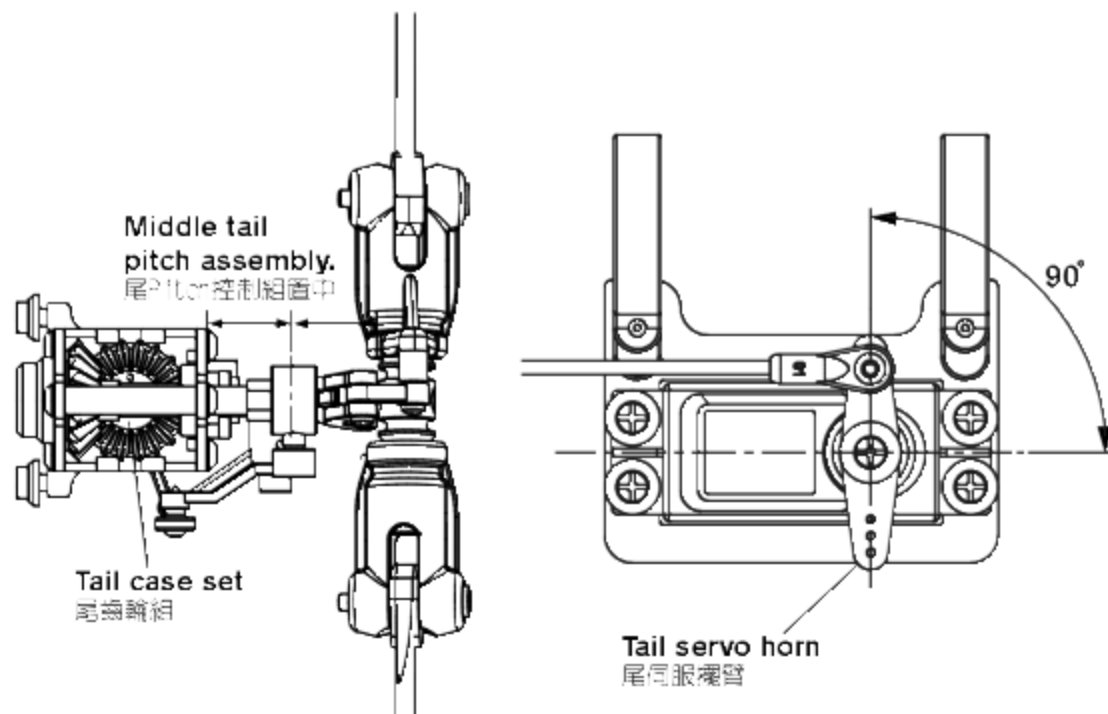

**HEAD LOCK DIRECTION SETTING OF GYRO 陀螺儀鎖定方向設定**

To check the head lock direction of gyro is to move the tail counterclockwise and the tail servo horn will be trimmed clockwise. If it trims in the reverse direction, please switch the gyro to "REVERSE".

陀螺儀鎖定方向確認，當手搖尾部反時鐘擺動，尾伺服器應順時鐘修正，反向時請切換陀螺儀上"鎖定反向"開關修正。

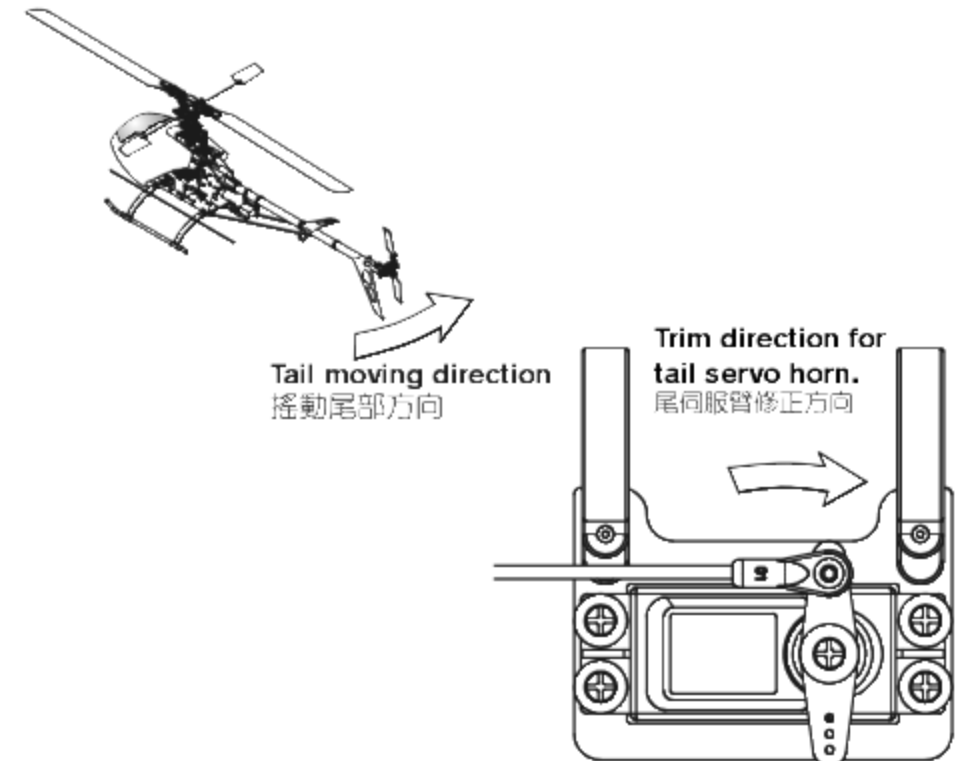

## GENERAL FLIGHT 一般飛行模式

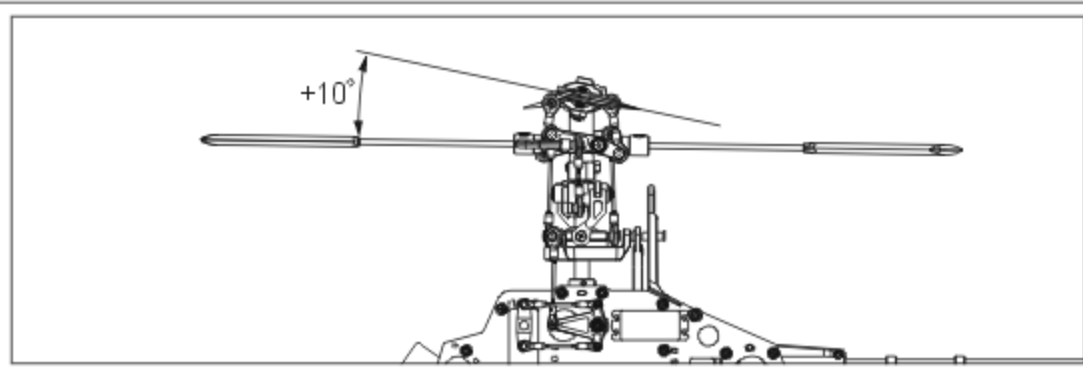

Stick position at high/Throttle 100%/Pitch +10°  
搖桿高速/油門100%/Pitch+10°

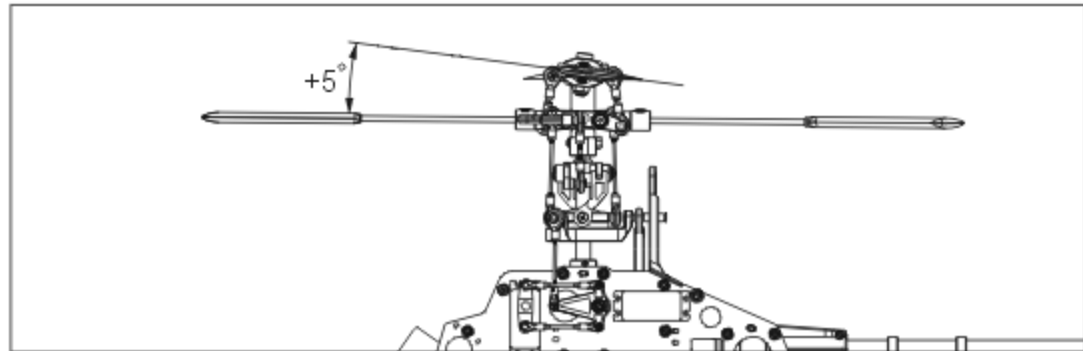

Stick position at Hovering/Throttle 65%~70%/Pitch+5°  
搖桿停懸/油門65%-70%/Pitch+5°

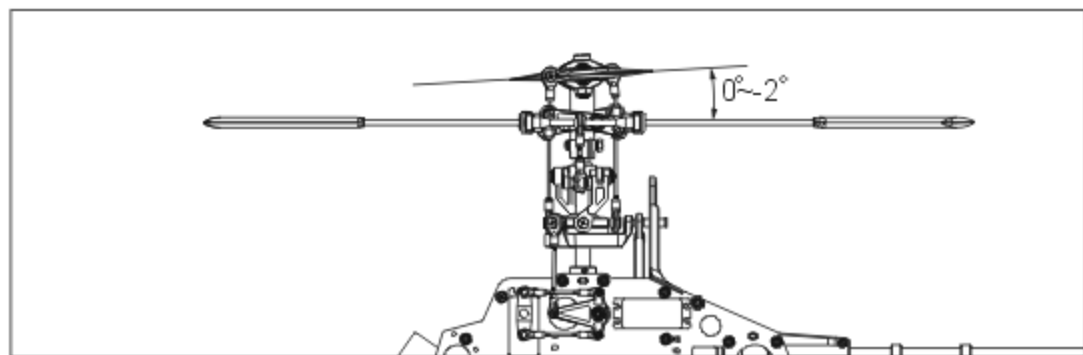

Stick position at low/Throttle 0%/Pitch 0°~-2°  
搖桿低速/油門0%/Pitch 0°~-2°

### GENERAL FLIGHT 一般飛行模式

Throttle 油門	Pitch 螺距
5 100% High speed 100% 高速	+10°
4 85%	
3 65% Hovering 65% 停懸	+5°
2 40%	
1 0% Low speed 0% 低速	0°

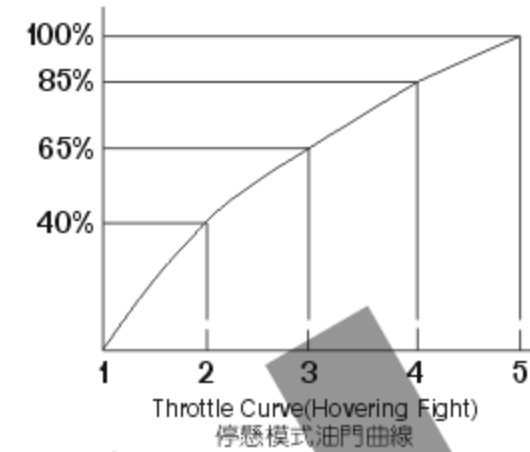

### Pitch and Rotation Speed Pitch與轉速關係

**TIP:** It is recommended to use a lower pitch setting when using higher RPM Head speed. This will allow for better power.  
搭配要領: 如果使用較高轉速馬達動力建議搭配調低 Pitch, 將獲得較佳動力效能。

## 3D FLIGHT 3D特技飛行模式

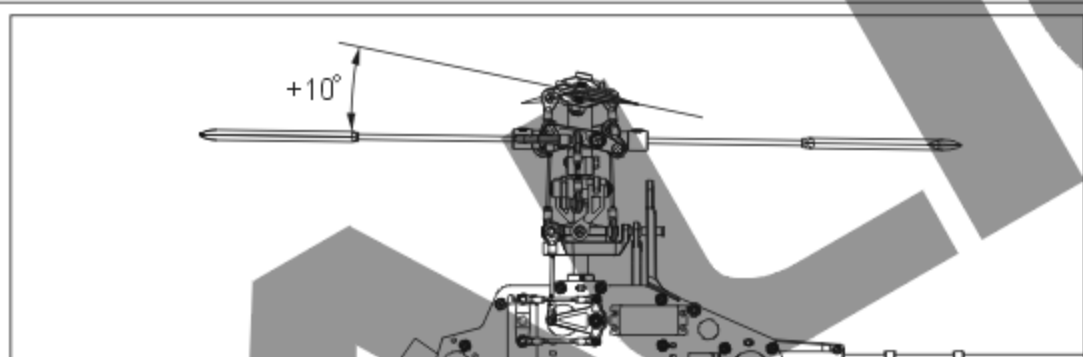

Stick position at high/Throttle 100%/Pitch +10°  
搖桿高速/油門100%/Pitch+10°

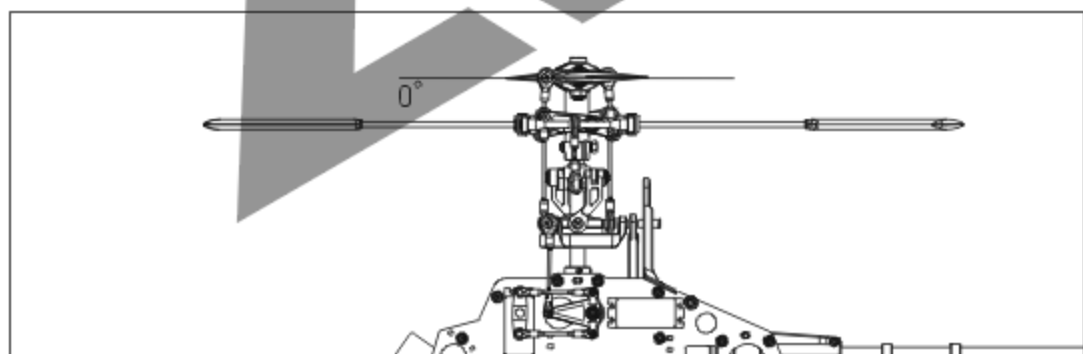

Stick position at middle/Throttle 85%/Pitch 0°  
搖桿中速/油門85%/Pitch 0°

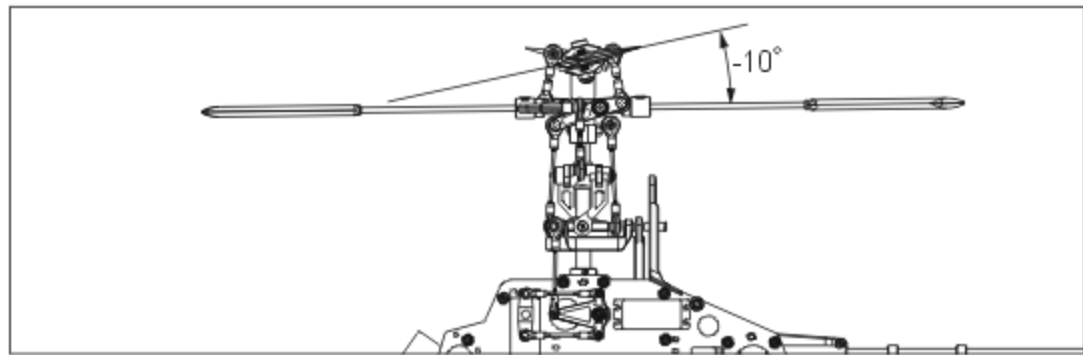

Stick position at low/Throttle 100%/Pitch -10°  
搖桿低速/油門100%/Pitch-10°

### IDLE 1: SPORT FLIGHT

Throttle 油門	Pitch 螺距
5 100%	+10°
4 75%	
3 70%	+5°
2 75%	
1 80%	-5°

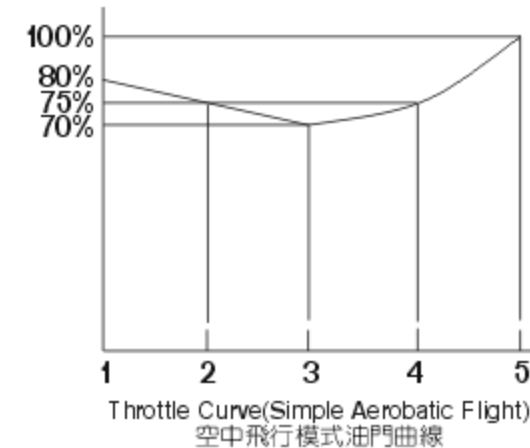

### IDLE 2: 3D FLIGHT

Throttle 油門	Pitch 螺距
5 100% High 100% 高	+10°
3 85% Middle 85% 中	0°
3 100% Middle 100% 中	0°
1 100% Low 100% 低	-10°

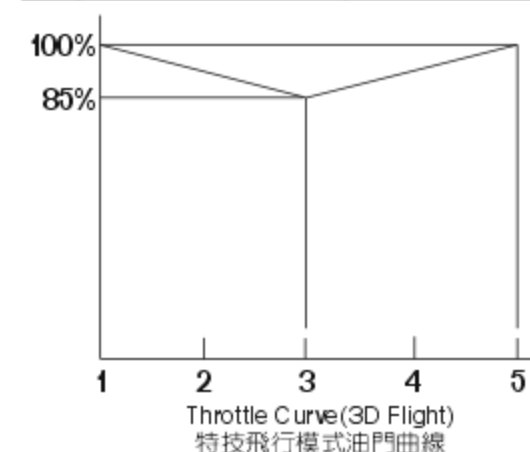

1. Pitch range: Approx 27 degrees.
2. If the pitch is set too high, it will result in shorter flight duration and poor motor performance.
3. Setting the throttle to provide a higher speed is preferable to increasing the pitch too high.



1. 螺距 (Pitch) 總行程約 27°
2. 過大螺距設定, 會導致動力與飛行時間降低。
3. 動力提升以較高轉速的設定方式, 優於螺距調大的設定。

## BATTERY 電池 :ALIGN Li-Poly 22.2V 5200mAh

Motor Pinion Gear 馬達主齒	Main Rotor Blade 主旋翼規格	Pitch 螺距	Current(A) approx. 電流(A)大約值	Throttle Curve 油門曲線	RPM approx. 主旋翼轉速大約值	
14T	600mm Carbon Fiber Blades 600碳纖主旋翼	Hover 停懸	+5°	15	0/50/65/85/100%	1610
		Idle 1	0°	20.5	85%Middle中	2220
			0°	25.4	100/100/100/100/100%	2380
			±10°	55		2200
15T	600mm Carbon Fiber Blades 600碳纖主旋翼	Hover 停懸	+5°	16	0/50/60/85/100%	1640
		Idle 2	0°	23	85%Middle中	2320
			0°	28.5	100/100/100/100/100%	2500
			±10°	62		2300

**NOTE: 1. Please use a pitch gauge to adjust the pitch value. Incorrect excess pitch setting will result poor helicopter performance and reduce ESC's life and battery's life.**

註：1.請務必使用螺距規來量測調整螺距，不正確的過大螺距設定不但無法發揮直昇機的特性，反會影響到無刷調速器與電池的壽命。

# 12.RCE-BL100G BRUSHLESS SPEED CONTROLLER INSTRUCTION MANUAL 無刷調速器使用說明

## PRODUCT FEATURES 產品特色

1. Three programmable throttle speed settings to support quick throttle response.
  2. Governor Mode(governor speed controller、slow down system)
  3. Small and compact PCB design for ease of installation.
  4. Large heatsink for great thermal performance.
  5. High compatibility to work with 98% brushless motors in the market.
  6. Ultra smooth motor start design to run with all kinds of brushless motors.
  7. The power inlet adapts Japanese made "Low ESR" capacitor in order to provide stable power source.
  8. The throttle has more than 200 steps resolution that provides great controlling sense.
  9. Users can use the transmitter to operate the motor setting by Super stylized CPU.
  10. If the aircraft should land or crash in an unexpected location and become lost, the pilot can enable the Aircraft Locator Option. The Aircraft Locator Option is engaged by turning off the transmitter. When the ESC does not receive a signal from the transmitter for 30 seconds, it will start to send an alarm to the motor. The sound of the alarm will aid the pilot to locate the aircraft. This option will not work with a PCM receiver that has SAVE function enabled, or with low noise resistant PM receivers.
1. 三段可程式油門反應速度，使動力的反應隨傳隨到  
 2. 具Governor Mode(緩啟動、定速模式)  
 3. 體積小，窄型設計，安裝於機身容易  
 4. 高散熱鋁合金片設計，可增強功率輸出延長電變使用壽命  
 5. 超高相容性，可對應市面上98%無刷馬達  
 6. 絕佳起步設計，無論國產、進口、內轉、外轉無刷馬達皆起步順暢  
 7. 電池電源端採用日製Low ESR 低阻抗電解電容，大幅提高電源之穩定性  
 8. 油門達200段以上解析度，無格數之油門感覺  
 9. 超強可程式化CPU，使用者可利用遙控器執行馬達特性驅動設定  
 10. 當飛機降落在長草區無法以目視定位時，使用者可將發射機關閉，電變無法接收來自接收機信號時，電變會於三十秒後使馬達發出警示警響，以利定位。此功能不適用於設定了SAVE功能之PCM接收機，或抗雜訊低之PPM接收機。

## WIRING ILLUSTRATION 接線示意圖

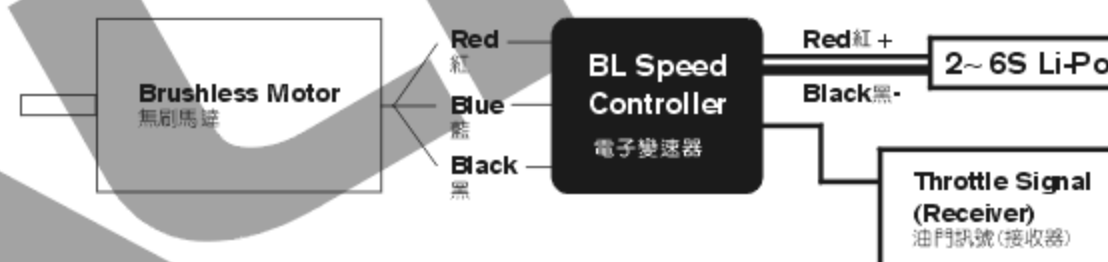

## SPECIFICATION 規格

Model 型號	Continuous Current 持續	Peak Current 瞬間	Dimension 尺寸	Weight 重量
RCE-BL100G	100A	135A	72x28x14mm	69g

1. Good temperature situation for working at the maximum current
  2. Supporting motor types: 2 ~ 10 pole in/outrunner brushless motors.
  3. Supporting maximum RPM: 2 pole → 190,000 rpm ; 6 pole → 63,000 rpm.
  4. Input voltage: 5.5V ~ 25.2V(2~6S Li-Po)
- NOTE: 1. When setting to the Quick throttle response speed, the accelerative peak current will increase.  
 2. Not including BEC output. User need to provide the power for receiver and servo.

1. 持續最大電流需在機體散熱良好情況下。
  2. 支援馬達型式：二極至十數極之內外轉子無刷馬達。
  3. 支援最高轉速：二極→190,000rpm；六極→63,000rpm。
  4. 輸入電壓：5.5V~25.2V(2~6s Li-Po)
- 注意：1. 設定為高油門反應速度時，加速瞬間電流會有增大情形。  
 2. 無BEC輸出，需額外提供接收器及伺服器電源。

## FUNCTIONS 產品功能

1. Brake Option - 3 settings that include Brake disabled/Soft brake/Hard brake.
2. Electronic Timing Option - 3 settings that include Low timing/Mid timing/High timing. Generally, 2 pole motors are recommended to use low timing, while 6 or more poles should use Mid timing. High timing gives more power at the expense of efficiency. Always check the current draw after changing the timing in order to prevent overloading of battery.
3. Battery Protection Option- 2 settings that include Li-ion, Li-poly High/Middle cutoff voltage protection. The default setting is high cutoff voltage protection. CPU will automatically determine cell number of input Lithium battery (2S~6S). This option will prevent over-discharge of the battery. The following reference is the guideline for setting the Battery Protection option.  
 3-1 Li-ion/Li-poly High cutoff voltage protection-When the voltage of single cell drops to 3.2V, the first step of battery protection mode will be engaged by the ESC resulting in reduced power. The pilot should reduce the throttle and prepare landing. If the voltage of single cell drops to 3.0V, the second step of battery protection mode will be engaged resulting in power cutoff. (\*Note 1) For 11.1V/3cells Lithium battery, the full charged voltage will be approximately 12.6V. According to this input voltage, CPU will determine that this is a 3cell battery.  
 First step protection: 3.2V x 3cell=9.6V  
 Second step protection: 3.0V x 3cell= 9.0V  
 When the voltage drops to 9.6V, the power will be reduced. When the voltage drops to 9.0V, the power will be cut off.



3-2 Li-ion/Li-poly Middle cutoff voltage protection- This option is same as instruction 3-1, but when the voltage of single cell drops to 3.0V, the first step of battery protection will be engaged. When the voltage of single cell drops to 2.8V, the second step of battery protection will be engaged. (\*Note 1)

Note 1: Second step of battery protection only works when Aircraft mode is setting to the option 4-1.

NOTE: THIS OPTION IS ONLY SUITABLE FOR A FULLY CHARGED BATTERY PACK IN GOOD WORKING CONDITION.

- Aircraft Option: 3 settings that include Normal Airplane / Helicopter 1 / Helicopter 2.  
Normal Airplane Mode is used for general airplanes and gliders. When flying Helicopters, you can choose Helicopter 1 Mode, or Helicopter 2 Mode. Helicopter 1 Mode provides Soft Start feature. Helicopter 2 Mode provides Soft Start and Governor Mode.
  - Throttle response speed 3 settings that include standard/ Medium/ Quick throttle response speed.  
The default setting is "quick speed". Use this option to adjust the setting according to flight character. For example, setting at Medium or Quick speed for 3D and powerful flight to make the power response more quickly, but note the accelerative peak current and power expense will increase.
  - Thermal Protection: When the ESC temperature reaches 80 C for any reason, it will engage the battery protection circuit, reducing power to the ESC. We recommend mounting the ESC in a location with adequate air flow and ventilation.
  - Safe Power On Alarm: When the operator turns on the ESC, it will automatically detect the transmitter signal. The ESC will emit a confirmation tone and enter normal operation mode if the throttle is set to the lowest position. If the throttle position is at full throttle, it will begin to enter Setup Mode. If the throttle is in any other position, the ESC will emit an alarm and not enter into user mode for safety precautions.
  - Aircraft Locator: If the aircraft should land or crash in an unexpected location and become lost, the pilot can enable the Aircraft Locator Option. The Aircraft Locator Option is engaged by turning off the transmitter. When the ESC does not receive a signal from the transmitter for 30 seconds, it will start to send an alarm to the motor. The sound of the alarm will aid the pilot to locate the aircraft. This option will not work with a PCM receiver that has SAVE function enabled, or with low noise resistant PPM receivers.
- 煞車設定:三段選擇分為無煞車 / 軟性煞車 / 急煞車
  - 進角設定:三段選擇分為低進角 / 中進角 / 高進角  
設定時機分為二極以及六極以上無碳刷馬達,二極無碳刷馬達一般適用低進角,若希望馬達轉速提高,可將進角設定為中進角。六極以上無碳刷馬達一般適用中進角,若希望馬達轉速提高,可將進角設定為高進角。然而進角之調整需要注意電流之變化,避免電池過載,影響電池及馬達壽命。
  - 電池保護電壓設定:二段選擇分為Li-Ion、Li-Po 高截止電壓保護/低截止電壓保護  
出廠設定為高截止電壓保護(適合停旋及一般飛行使用);此功能會自動判定所輸入鋰電池的cell數(7.4~25.2V),並提供使用者對該電池之放電保護,以避免因放電電壓過低而造成電池損壞,以下為設定值之解說:  
3-1 Li-Ion/Li-Po高截止電壓保護:當電壓單cell壓降達3.2V時,電變會啟動第一階段保護,使動力間歇性中斷,此時使用者應將油門收小,準備降落;而當單cell電壓持續壓降達到3.0V時則會啟動第二階段保護,完全限制動力輸出(註1:僅在4-1選項"一般飛機模式"下才會啟動第二階段保護)。  
例:以一個使用11.1V 3cell鋰電池之系統而言11.1V鋰電池充飽電壓約12.6V,此輸入電壓CPU會自動判定為3cell鋰電。  
第一階段保護:3.2Vx3cell=9.6V 第二階段保護:3.0Vx3cell=9.0V 當電壓降至9.6V時,動力會間歇性中斷,當壓降達到9.0V時則完全限制動力輸出。  
3-2 Li-Ion/Li-Po中截止電壓保護:同3-1功能說明,但單cell壓降達到3.0V時,會啟動第一階段保護,單cell壓降達到2.8V時啟動第二階段保護(註1)。  
注意:以上功能僅適用於充飽電,且功能正常的鋰電池。
  - 飛機模式設定:三段式選擇分為:一般飛機模式/直昇機模式1/直昇機模式2  
使用於一般飛機或滑翔機時,請設定於一般飛機模式,使用於直昇機時可選擇直昇機模式1:具有緩啟動功能,或直昇機模式2:具有緩啟動及Governor Mode定速功能。
  - 油門反應速度設定:三段選擇分為標準/中速/快速  
出廠設定值為"快速"油門反應速度,此功能提供使用者依所需的飛行特性來作適當的調整,例如3D飛機與劇烈的3D直昇機飛行時可設定為中速或快速,使動力反應更加快速、靈敏,但須注意提高油門反應速度時,加速瞬間電流與耗電量會有增大的情形。
  - 溫度保護:當電變因不良之空氣對流或是過載輸出導致溫度上升達 80°C時,電變會啟動溫度保護,而使動力間歇性中斷,建議將電變裝置在機艙內空氣對流之位置,並實際使用電流量表測輸出電流,以達到電變之最佳效率。
  - 開機防暴提醒功能:當使用者開啟電變電源時,系統會自動偵測發射機之設定,如果發射機油門未置於最低點,或未置於最高點準備進入設定模式,馬達將不會轉動,同時會有警示聲響提醒。
  - 尋機功能:當飛機降若再長草區無法以目視定位時,使用者可將發射機關閉,當電變無法接收來自接收機信號時,電變會於三十秒後使馬達發出警示聲響,以利定位。此功能不適用於設定了SAVE功能之PCM接收機,或抗雜訊低之PPM接收機。

### SETUP MODE 設定模式

- Setup mode: Make sure to connect the ESC to the throttle channel of the receiver. Please refer to the user manual of your radio system.  
The second step is to connect the 3 power-out signal pins to the brushless motor.  
Before you turn on the transmitter, please adjust the throttle stick to the maximum full throttle position. Proceed to connect the battery to the ESC. You will hear confirmation sounds as soon as you enter the SETUP MODE. Please refer the attached flow chart for details.
  - Throttle stick positions in Setup mode: Setup mode includes six settings: Brake, Electronic Timing, Battery Protection, Aircraft, Throttle Response Speed and BEC output voltage. Every setting has three options. Simply place the throttle stick in the highest, middle, and lowest positions for each setting. For example, first brake setting (Hard):  
move the stick to the highest position. Then timing setting (mid): move the throttle stick in the middle position.
- 進入設定模式:將電變與接收器之油門 Channel 連接,不同之遙控系統請參閱您遙控系統之使用手冊,馬達之三條線亦與電變連接,將發射器之油門搖桿推到最高點,使之於全油門狀態,先開啟發射器電源,再將電源連接至電變,進入設定模式後,馬達將有設定模式之提示聲響。請參考第二頁程式化設定模式說明。
  - 設定模式中之動作:設定模式共含有六項設定,分別為煞車、馬達進角、電池保護、飛機模式、油門反應速度級、BEC 輸出電壓等設定,詳細內容請參考產品功能之解說。每一項設定中各含三段設定,各項設定以油門搖桿之上、中、下位置來決定其設定值。  
例如:煞車設定時,油門搖桿撥至最高,則設定為急煞車,進入第二項進角設定時,油門搖桿撥至中間,則設定為中進角。

Mode 設定模式	Throttle position 油門搖桿	Low 低	Middle 中	High 高
Brake 煞車設定		● Brake disabled(1-1) 無煞車(1-1)	Soft brake(1-2) 軟性煞車(1-2)	Hard brake(1-3) 急煞車(1-3)
Electronic Timing 進角設定		Low-timing(2-1) 低進角(2-1)	● Mid-timing(2-2) 中進角(2-2)	High-timing(2-3) 高進角(2-3)
Battery Protection 電池保護電壓設定		● High cutoff voltage protection(3-1) 高截止電壓保護(3-1)	Middle cutoff voltage protection(3-2) 中截止電壓保護(3-2)	—
Aircraft 飛機模式設定		Normal Airplane/Glider(4-1) 一般飛機 / 滑翔機 (4-1)	● Helicopter 1 (Soft Start)(4-2) 直升機模式1(緩啟動功能)(4-2)	Helicopter 2 (Soft Start + Governor Mode)(4-3) 直升機模式2(緩啟動+Governor Mode定速功能)(4-3)
Throttle response speed 油門反應速度設定		Standard(5-1) 標準(5-1)	Medium speed(5-2) 中速(5-2)	● Quick speed(5-3) 快速(5-3)

Note: "●" default setting  
註: "●" 表示出廠設定值

Chart A  
表A

### ESC START-UP INSTRUCTION 開機使用模式



### CURRENT SETTINGS INDICATOR BEEPS EXPLANATION 開機模式設定響音提示說明

First Beep Group Brake Status 第一個響音 煞車設定狀態提示	Second Beep Group Electronic Timing 第二個響音 進角設定狀態提示	Third Beep Group Battery protection Cutoff 第三個響音 電池保護設定狀態提示	Fourth Beep Group Aircraft Status 第四個響音 飛機模式設定狀態提示	Fifth Beep Group Throttle Response 第五個響音 油門反應速度設定狀態提示
<ul style="list-style-type: none"> <li>● = Brake disabled = 無煞車</li> <li>●● = Soft brake = 軟性煞車</li> <li>●●● = Hard brake = 急煞車</li> </ul>	<ul style="list-style-type: none"> <li>● = Low timing (apply to 2 pole inrunner motors) = 低進角(適合2級內轉子馬達)</li> <li>●● = Mid timing (apply to 6 pole in/out runner motors) = 中進角(適合6級內外轉子馬達)</li> <li>●●● = High timing (apply to high power output) = 高進角(適用於高功率輸出)</li> </ul> <p>High-timing/big power output 高進角模式有較大功率與耗電特性</p>	<ul style="list-style-type: none"> <li>●●● = High cutoff voltage protection = 高截止電壓保護</li> <li>●● = Middle cutoff voltage protection = 中截止電壓保護</li> </ul>	<ul style="list-style-type: none"> <li>●●● = Normal airplane/Glider = 一般飛機/滑翔機</li> <li>●●●● = Helicopter 1 (Soft start) = 直昇機模式1(緩啟動功能)</li> <li>●●●●● = Helicopter 2 (Soft start + Governor Mode) = 直昇機模式2(緩啟動功能+Governor Mode定速功能)</li> </ul>	<ul style="list-style-type: none"> <li>●●● = Standard = 標準</li> <li>●●●● = Medium speed = 中速</li> <li>●●●●● = Quick speed = 快速</li> </ul>

## INSTRUCTIONS ON AIRCRAFT MODE SETTINGS 飛機模式設定使用說明

### Normal Airplane/Glider Mode (Option 4-1):

This option is applied to general airplanes and gliders.

### Helicopter 1 Mode (Option 4-2):

This option provides a soft start feature and is applied to Helicopters for Normal, Idle Up 1, or Idle Up 2 modes.

Please note that the sensitivity of the gyro should be set lower when flying in Idle Up 1 or Idle Up 2 modes if tail hunting (wag) occurs due to higher rotor speed.

### Helicopter 2 Mode (Option 4-3):

This option supports soft start as well as Governor Mode features and is applied to Helicopters for Idle Up 1 and Idle Up 2 modes (not suitable for Normal Flight Mode). When Governor Mode is in use, the throttle should be set between 75% and 85%. Again if tail wag occurs, lower the sensitivity of the gyro to eliminate the hunting effect. The Governor Mode may not work properly in cases of insufficient rotor speed (due to improper gear ratio), poor battery discharge capability, and improper setting of gyro sensitivity and the blade pitch, etc. Please make sure all the proper adjustments have been done when using Governor Mode.

一般飛機模式(選項4-1):適用於一般飛機及滑翔機。

直昇機模式1(選項4-2):具有緩啟動功能,適用於Normal、Idle1、Idle2等飛行模式,當切換至Idle1或Idle2模式,如有較高轉速造成陀螺儀有輕微的追蹤現象,此時應將陀螺儀的感度設定分別降低。

直昇機模式2(選項4-3):具有緩啟動及Governor Mode定速功能,適用於Idle1、Idle2特技飛行模式(不適合Normal飛行模式下選用),選擇定速功能時,油門應定速在75%-85%之間,如果飛行時發現有輕微的追蹤現象時,應降低陀螺儀的感度;由於轉速不足(齒比搭配不當),電池效能不佳,陀螺儀感度設定不當,Pitch設定錯誤,皆會導致無法發揮定速的功能,甚至產生尾部擺擺的情形,所以選擇此模式時應針對相關條件進行確認。

## SETUP MODE 程式化設定模式

Minimum 4 channel radio is required 四動以上標準發射器均可執行設定

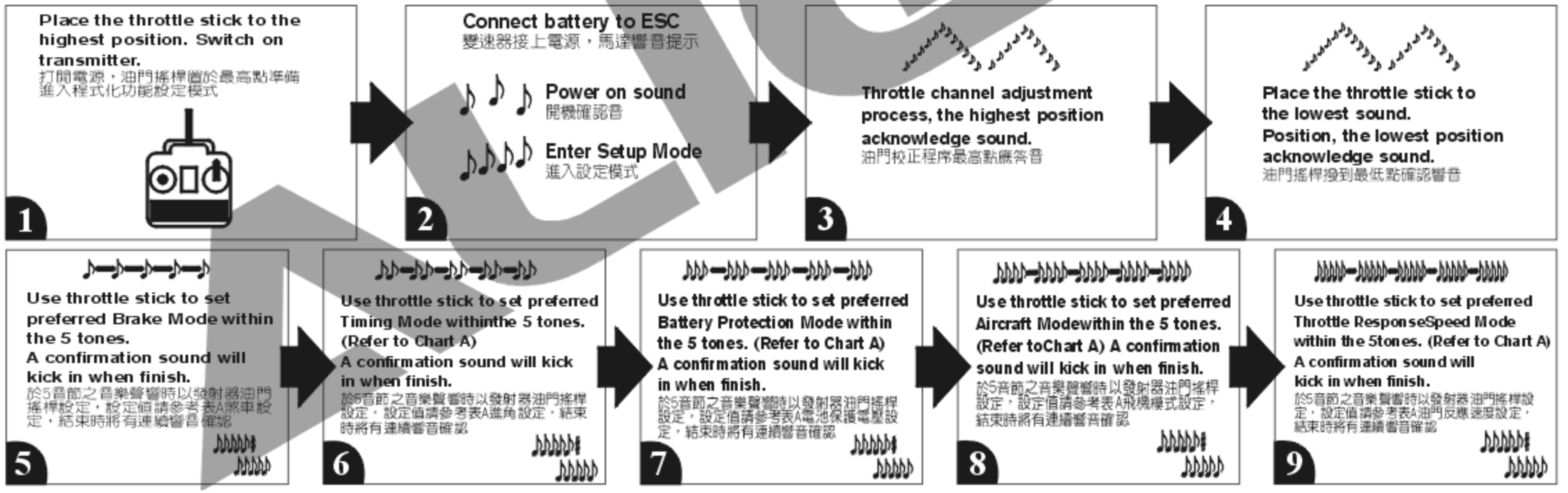

## 13. 6A EXTERNAL BEC INSTRUCTION MANUAL 6A外接式BEC使用說明

ALIGN

- Input voltage: DC 7.4V 2 cell Lithium battery ● Output voltage: DC 5.8V ● Max. Continuous Current: 6A
- Integrated power switch and voltage indicator meter ● Utilizes a linear design, resulting in no interference to the receiver. ● Including a 5A 5.1V two-way step-down Voltage Regulator ● Size: 60x34x15mm ● Weight: 31g (including wire set)
- 輸入電壓: DC 7.4V 2CELL 鋰電 ● 輸出電壓: DC 5.8V ● 最大連續輸出電流: 6安培 ● 具電源切換開關與電壓指示燈功能 ● 採線性設計, 無干擾接收機的缺點
- 附5A 5.1V雙向降壓器 ● 尺寸: 60x34x15mm ● 重量: 31g(含線組)

### WIRING ILLUSTRATION:

Connect a 5.1V two-way step-down voltage regulator between the gyro and the rudder servo.

接線示意圖:

5.1V 雙向降壓器連接於陀螺儀與尾舵伺服器之間。

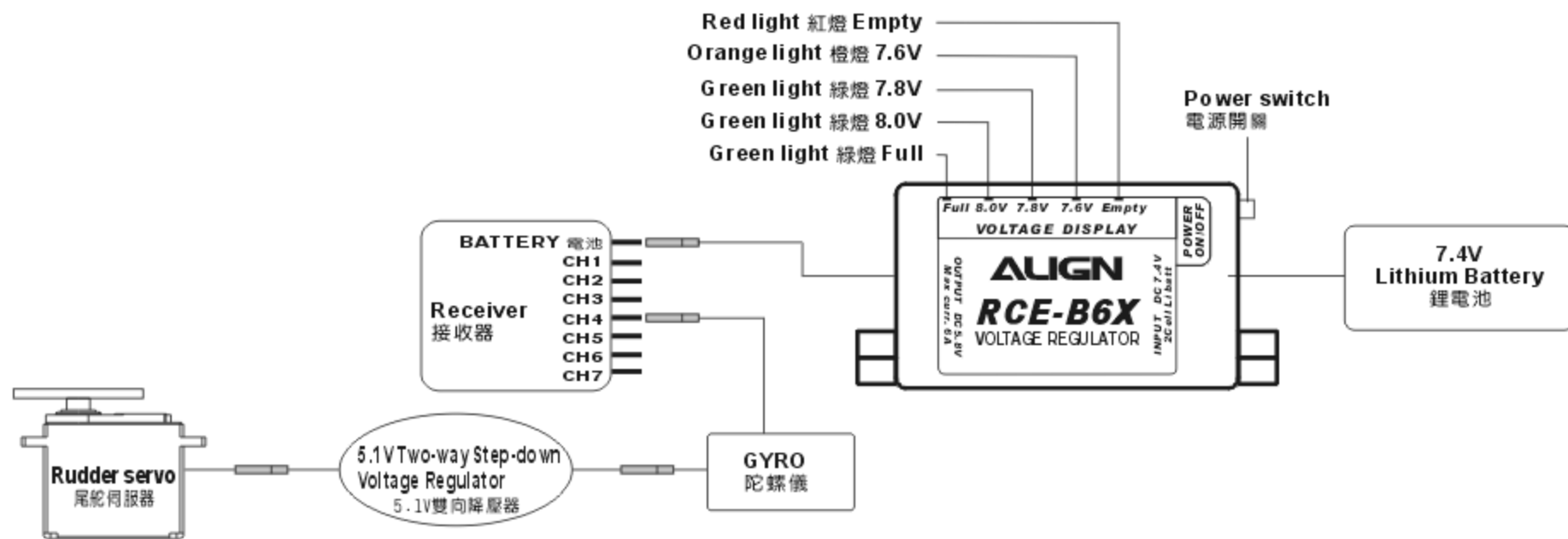

### Instruction:

1. Auto-detecting voltage meter display lights. If the entire five-light array is illuminated, the battery is fully charged. When the voltage drops below 7.6V, the three green lights will be turned off. Use caution, the battery can only be safely used for a single flight. When only the red light is on, the battery voltage is drained, and must be fully recharged before use. Do not attempt to operate the model during this condition!
2. Some servos such as Futaba servo models 9241, 9251, 9253, 9254, 9255, 9256 and other digital servos are not capable of handling 6V. Please connect a 5.1V two-way step-down voltage regulator to avoid the servo damaged. If you are using a servo that can accept 6V input, the regulator is not required.
3. When using a speed controller with BEC output, you must remove the red wire of BEC output on the speed controller.
4. If the receiver does not have enough channels or an available socket, you can use a Y-type servo harness to share any channel with an existing connection.

1. 本產品具電壓指示功能, 當接入充飽的電池時五顆指示燈全亮, 表示電池在Full電量充足狀態下; 使用中當電壓降低至7.6V時(3顆綠燈熄滅), 尚可完成單趟飛行即須對電池充電或更換新電池; 而如果僅亮紅燈時表示Empty電量不足, 不應該再使用喔!
2. 部份的伺服器如: Futaba 9241, 9251, 9253, 9254, 9255, 9256等, 此類型的伺服器不適合於較高的電壓下操作, 所以使用此類型的伺服器時請另外加裝5.1V降壓器, 避免伺服器損壞; 規格標示准許6V輸入的伺服器則不須使用降壓器。
3. 使用具BEC輸出之調速器時, 必須將調速器 BEC 輸出的紅色線拆除!
4. 若接收機已無多餘的電源插孔時, 可利用一條伺服 Y 型連接線, 接到接收機的任一通道, 再將外接 BEC 與拆下的通道一同接在 Y 型線上。

**NOTE: When fixing the wire, please do not over tighten to avoid the connector come off or the wire broken when the helicopter rotates (vibration); do not operate in rain or moisture environment to avoid the electric parts short circuit and damaged.**

注意: 固定線組時勿將各線組繃緊, 以免直昇機運轉時因震動造成接頭鬆脫或斷線; 避免在雨中或潮濕的環境下使用, 以免造成零件短路而損壞。

Features 產品特色

- Utilizes Silicon Micro Machines (S.M.M) sensor with excellent stability to dramatically reduce in-flight tail drifts.
- Utilizes AHTCS (Active Helicopter Tail Control System) to compensate any drift caused by wind direction and force, as well as unintended yaw induced by helicopter itself during flight maneuvers.
- Tailor made specifically for use with high speed digital rudder servos. This gyro features high sensitivity and minimal reaction time, fully utilizing the potential of modern high speed digital rudder servos.
- Suitable for all sizes of helicopters, from micro indoor to large 90 size glow helicopters.
- Metallic dampening plate built into bottom gyro casing, dramatically increasing anti-vibration and anti-interference abilities.
- Features 1520  $\mu$ s pulse wide and 760  $\mu$ s narrow pulse wide frame rate.
- Digital/Analog servo switchable.
- Reverse switch.
- Rudder servo travel limit adjustment (ATV).
- Mode switch for large/mini helicopter.
- Delay adjustment.
- Gyro locking mode and gain can be adjusted remotely from the transmitter.
- 採用S.M.M矽微細加工技術感知器，具有極佳的穩定性，大幅降低尾舵偏移的機會。
- 採用AHTCS (Active Helicopter Tail Control System)主動式直昇機尾旋翼控制系統，主動修正因風向、風力變化與直昇機不同飛行姿態所產生之偏移。
- 專為高速型數位伺服器量身打造，具有高靈敏度與極短的反應時間，完全發揮伺服器高速反應的鎖定能力。
- 適用迷你型室內電直至大型90油直。
- 下蓋與金屬防震片一體成型，大幅提升抗震防干擾能力。

- 相容標準1520  $\mu$ s與窄頻760  $\mu$ s伺服器。
- 數位/類比伺服器切換。
- 尾舵正逆向控制切換。
- LIMIT尾舵行程量設定。
- 大/小型直昇機模式切換。
- DELAY控制延遲量設定。
- 可由遙控器控制鎖定與非鎖定模式，以及調整陀螺儀感度。

Setting type 設定項目	1520/760 $\mu$ s	DS/AS	NOR / REV	LIMIT	Helicopter mode / DELAY 直昇機模式/DELAY
"STATUS"green "STATUS"綠燈	▲Standard 1520 $\mu$ s Servo ▲標準1520 $\mu$ s伺服器	▲Digital servo ▲DS數位伺服器	▲Normal rotation ▲NOR正轉	Left(Right)Travel limit 左(右)行程量	Medium/ large heli, suitable for T-REX 500/600/700 中型/大型直昇機 適用T-REX 500/600/700
"STATUS"red "STATUS"紅燈	Narrow band 760 $\mu$ s Servo 窄頻760 $\mu$ s伺服器	Analog Servo AS類比伺服器	Reverse rotation REV反轉	Right(Left)Travel limit 右(左)行程量	Mini/ Micro heli, suitable for T-REX250/450 小型/迷你型電直 適用T-REX 250/450
Setting instruction 設定方式說明	See no. 2 in setting instructions 參照設定方式第2項	See no. 3 in setting instructions 參照設定方式第3項	See no. 5 in setting instructions 參照設定方式第5項	See no. 6 in setting instructions 參照設定方式第6項	See no. 8 in setting instructions 參照設定方式第8項

NOTE: 1. "▲"Default setting. 2. Wrong heli mode will affect the performance of gyro. Do not fly before the complete setting.

註: 1. "▲"表示出廠設定值。 2. 錯誤的直昇機模式將影響陀螺儀性能，未完成設定前請勿飛行。

T-REX600/700 Standard setting T-REX600/700 標準設定

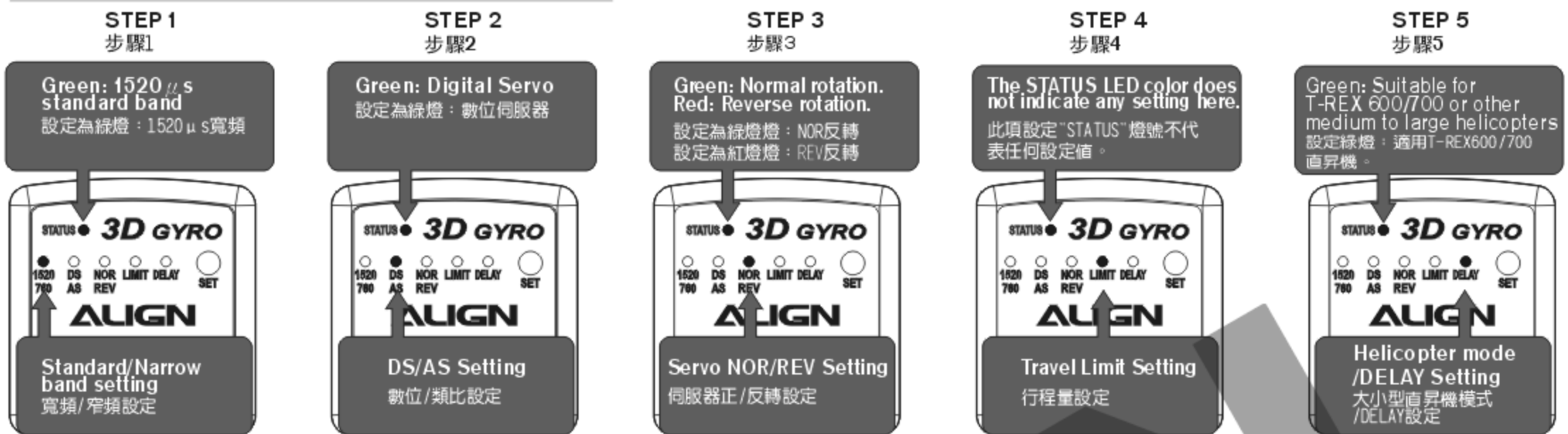
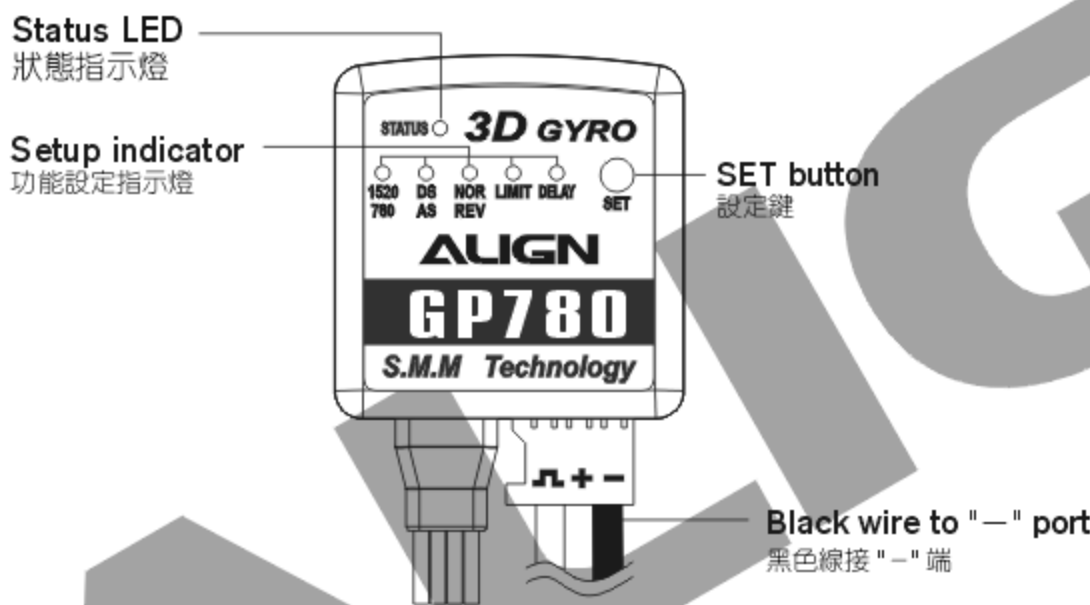

Diagram 各部名稱



GP780 Gyro Specifications GP780陀螺儀產品規格

- Operating Voltage: DC 4.5~7V
- Current Consumption: <80mA @ 4.8V
- Angular Detection Speed:  $\pm$ 500 degrees/sec
- Operating Temperature: -20°C~65°C
- Operating Humidity: 0%~95%
- Size: 26x25x11mm
- Weight: 14g
- RoHS compliant
- 適用電壓: DC 4.5~7V
- 消耗電流: <80mA @4.8V
- 偵測角速度  $\pm$ 500度/sec
- 操作溫度: -20°C~65°C
- 操作濕度: 0%~95%
- 尺寸: 26x25x11mm
- 重量: 14g
- 符合RoHS限用規章

DS620 Digital Servo DS620數位伺服器

- Speed: 0.09sec /60 degrees(4.8V)  
0.07sec /60 degrees(6.0V)
- Torque: 8.0kg.cm (4.8V)  
10.0kg.cm (6.0V)
- Dimension: 40.3 x 20.1 x 36mm
- Weight: 52.2g(Servo horn not included)
- 1520  $\mu$ s (standard band)
- 動作速度: 0.09sec/60° (4.8V)  
0.07sec/60° (6.0V)
- 輸出扭力: 8.0kg.cm (4.8V)  
10.0kg.cm (6.0V)
- 尺寸: 40.3x20.1x36mm
- 重量: 52.2g(不含舵角片)
- 1520  $\mu$ s (寬頻系統)

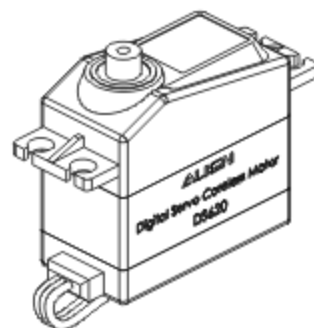
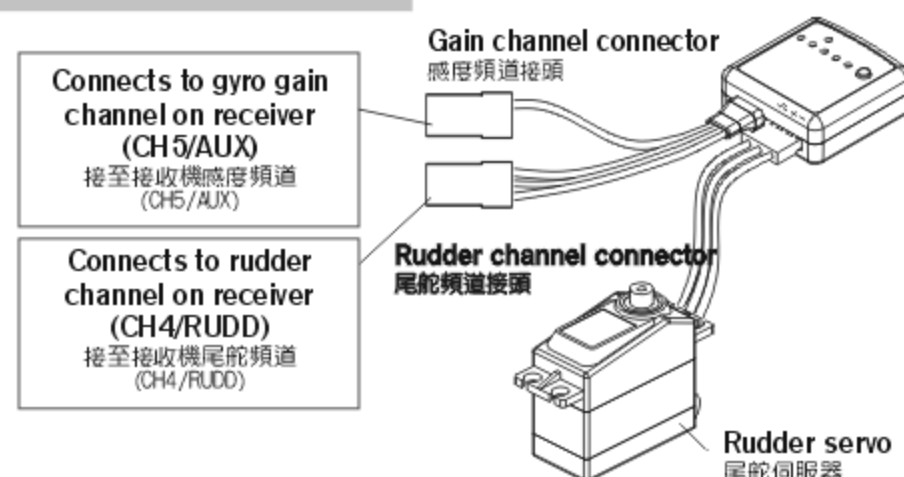

Illustration 接線示意圖



## Gain and Rudder channel mapping diagram 連接對照表:

Transmitter type 遙控器種類	Rudder channel on Receiver 尾舵頻道接頭至接收器	Gain channel on Receiver 感度頻道接頭至接收器
JR PPM/SPCM	"RUDD"	"AUX 2" or "AUX 3"
Hitec Futaba PPM/PCM	"CH4"(RUD)	"CH5"
JR ZPCM	"RUDD"	"AUX 2"

### Gyro Installation 陀螺儀的安裝

- Utilizing the included double sided foam tape as shown in diagram beside, mount the gyro on a solid platform or designated gyro mounting location on the helicopter. Ensure gyro mounting area have proper ventilation and away from heat sources.
- To avoid drift induced by erroneous yaw detection, the bottom surface of gyro must be perpendicular (90 degrees) relative to the main shaft.
- For installation on electric powered helicopters, the gyro should be installed as far away from the electronic speed controller (ESC) as possible to avoid interference (minimum 5cm).

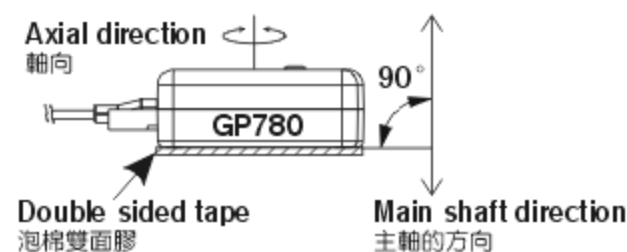

- 利用所提供的泡棉雙面膠如右圖方式，把陀螺儀固定在穩定的平台上或機體預留的陀螺儀座，並確保它在通風良好的區域，遠離熱源。
- 陀螺儀底部水平貼附與直昇機的主軸呈垂直90度，否則會影響感知器對角度變化的偵測，造成偏移。
- 安裝於電動直昇機時盡量遠離(5公分以上)馬達與電子調速器，避免干擾情形發生。

### Usage Setting Instructions 使用及設定方式

- Transmitter Settings:** After powering up transmitter, make sure rudder subtrim is zeroed. Then power on the receiver and gyro. The gyro will go through initializing process indicated by flashing LED from left to right. Do not touch the heli or transmitter sticks until initializing is complete, as indicated by a steady lit LED. A green LED indicates gyro is in AHTCS locking mode, while red LED indicates gyro is in normal mode.

**Note:** The GP780 is set to 1520  $\mu$ s at the factory. If 760  $\mu$ s servo is used in 1520  $\mu$ s mode, rudder servo will deflect to the side and unable to center. For more critically, the linkage rod may jam and cause the servo burned out. Please follow the instruction (Usage setting 2) to change the setting if 760  $\mu$ s servo is used. Please ensure the following mixing functions (if available) are disabled or zeroed on the transmitter.

- ATS
- Pilot authority mixing
- Throttle to rudder mixing
- Rudder to gyro mixing
- Pitch to rudder mixing
- Revolution mixing

- 1520  $\mu$ s (standard) or 760  $\mu$ s (narrow band) servo selection:** GP780 offers compatibility for two types of frame rates under digital mode. Please set the GP780 to 760 mode if 760  $\mu$ s frame rate rudder servos (such as Futaba S9256, S9251, BLS251) are used.

Most other servos have 1520  $\mu$ s frame rate, and GP780 should be set to 1520 mode if those servos are used.

To enter the setup mode: Press and hold the SET button for 2 seconds, and the STATUS LED will begin flashing. When the 1520/760 indicator lit up, you are in the servo frame rate setup menu. Use the rudder stick on your transmitter to select the frame rate: move the stick to left (or right) and STATUS led changes to green, the frame rate has been set to 1520  $\mu$ s. If you want to set the frame rate to 760  $\mu$ s, move the stick to opposite end 3 times to make STATUS led changes to red. (Note: The faceplate of GP780 has the setting values listed in the corresponding green/red letters.)

Press the SET to confirm the current setting and enter the next setting. The GP780 will exit setting mode if left idle for 10 seconds.

- Digital (DS) / Analog (AS) Servo Selection:** Servo speed is of paramount importance in maximizing the gyro's performance.

Fast servos are able to respond to gyro commands quickly, resulting in the speed and precision of overall system. Due to the high sensitivity of GP780 gyro, high speed digital servos such as Align DS650, DS620, DS520, DS420, Futaba S9257, S9256, S9254, S9253, or other similar spec servos are recommended. Select "DS" when digital servos are used, and "AS" when analog servos are used.

To enter the setup mode: Press and hold the SET button for 2 seconds, and the STATUS LED will begin flashing. Press the SET button repeatedly until DS/AS led is lit. Use the rudder stick on your transmitter to select the Servo type: move the stick to left (or right) and STATUS led changes to green, the servo type is set to DS. Move the stick to opposite direction and STATUS led changes to red, the servo type is set to AS.

**Warning:** The use of analog servo under "DS" mode will result in servo failure. The GP780 gyros are set to "DS" mode at the factory. Please set the proper servo type based on servo used.

- Check the direction of rudder:** move the rudder stick on transmitter left/right and check the helicopter's instruction manual for correct rudder direction. Servo reverse function on the transmitter can be used for reversed rudder. Set the transmitter gyro gain channel to normal mode, or press and hold the SET button for 2 seconds to center the rudder servo. Adjust the servo horn so it is perpendicular (90 degrees) relative to the pushrod. Then adjust the rudder linkage length so the tail pitch control system is within range.

**Setting Method:** Press and hold the SET button for 2 seconds to enter the setup menu, and select DELAY setting. Push the rudder stick left or right and observe the STATUS LED. Red represents mini/micro helis, green represents medium/large helis.

The amount of delay is set by holding the rudder stick at the position corresponding the delay percentage, 0% at middle stick position and 100% at the end position, and pressing the SET button to confirm the delay setting.

- 檢查遙控器的設定：先開啟遙控器電源，將尾舵的微調歸零後，再開啟直昇機的接收機電源，此時陀螺儀會先進入初始化狀態，所有指示燈會由左至右閃爍，接著使尾舵伺服器回到中立點，在此之前請勿晃動直昇機或撥動尾舵搖桿，當狀態指示燈為綠色時表示陀螺儀在鎖定的狀態，指示燈為紅色時表示陀螺儀在非鎖定的狀態。

※註：GP780出廠時內建為 1520  $\mu$ s 系統，若使用 760  $\mu$ s 窄頻伺服器時，開機後尾伺服器將會偏向一邊無法置中，甚至造成連桿卡死而使伺服器燒毀，請參照使用及設定方式第2項更改設定值。

如果您的遙控器有下列功能時，請設定為關閉(OFF)或數值設定為零

- ATS
- Pilot authority mixing
- Throttle to rudder mixing
- Rudder to gyro mixing
- Pitch to rudder mixing
- Revolution mixing

- 1520  $\mu$ s (標準) 或 760  $\mu$ s (窄頻) 伺服器選擇：** GP780 相容兩種波寬控制系統，若您使用的伺服器屬於 760  $\mu$ s 系統(如 Futaba S9256、S9251、BLS251)，則必須將 GP780 設定於 760 的模式，其他未標示 760  $\mu$ s 規格的伺服器，一般皆為 1520  $\mu$ s 系統，必須將 GP780 設定為 1520 的模式。

如何進入功能設定模式：持按面板上的 "SET" 設定鍵約 2 秒，此時 "STATUS" 狀態指示燈會開始閃爍，且 "1520/760" 的功能設定指示燈會亮起，表示進入標準/窄頻伺服器選項，利用遙控器方向舵搖桿的左右方向來選擇設定值，例如方向舵搖桿往左(或右)時，"STATUS" 指示燈為綠色，表示設定值為 1520  $\mu$ s 系統；若要設定為窄頻 760  $\mu$ s 系統時，必須將搖桿由中立點往相反方向連續撥動 3 次，使 "STATUS" 指示燈亮紅色，才會進入 760  $\mu$ s 系統。(註：GP780 的面板標識上已使用綠/紅色的字體提示 "STATUS" 燈色所代表的設定值)。設定完成後按 "SET" 鍵一次可進入下一個設定，或是 10 秒內不做任何設定，GP780 會自動離開設定模式。

- DS 數位 / AS 類比伺服器選擇：** 伺服器動作速度與陀螺儀的性能，伺服器動作愈快，就能立即反應陀螺儀送出的指令，發揮快速精準的效能；由於 GP780 具有相當快速的反應時間與靈敏度，所以建議您搭配高速型數位伺服器，如 ALIGN DS650、DS620、DS520、DS420、Futaba S9257、S9256、S9254、S9253 或其他相同規格伺服器，以獲得最佳效能。設定方式：持按 "SET" 鍵 2 秒進入功能設定模式，再按 "SET" 鍵選擇 DS/AS 選項，(DS/AS 指示燈亮起)，利用方向舵搖桿選擇數位 DS (STATUS 為綠燈) 或類比 AS (STATUS 為紅燈) 伺服器。

注意：在 DS 模式下連接類比伺服器將導致伺服器燒毀，本產品出廠時設定在 DS 模式，請自行依所搭配的伺服器類型選擇正確的模式。

- 檢查尾舵伺服器正逆轉方向與調整連桿：** 左右撥動尾舵搖桿，確認尾舵伺服器移動的方向是否正確，若不正確請更改遙控器上的尾舵伺服器正逆轉方向。將 GP780 切換成非鎖定模式或持按 GP780 的 "SET" 鍵 2 秒，使尾舵伺服器保持在中立點的位置上，調整伺服器舵片，盡可能使尾舵連桿與伺服器舵片呈 90 度，接著調整連桿長度使尾舵 Pitch 控制組置中。

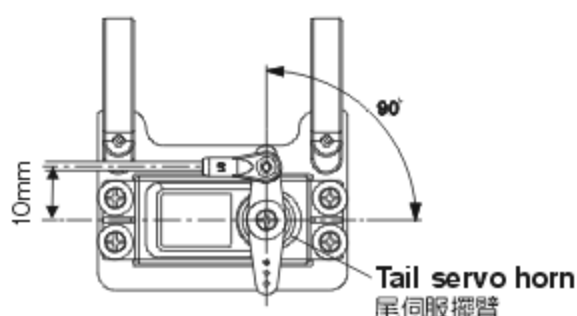

Utilizing DS620 rudder servo as an example, the recommended location of linkage connection is the second hole from the center of the servo horn. The ideal distance from linkage connection to servo center is 10mm.  
以 DS620 尾舵伺服器為例，建議將球頭鎖於於伺服器舵片由內算起的第二孔，使尾舵控制桿與伺服器平行距離 10mm 左右為最佳。

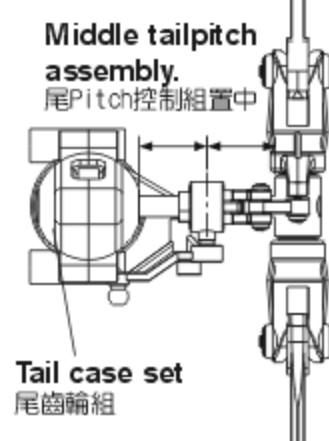

**5. Setting of gyro direction nor/rev:** Check the gyro direction by moving the heli on the yaw axis while holding by hand. Observe the direction gyro is moving the rudder servo. If direction is incorrect, switch the direction switch on the gyro to compensate.  
**To enter the setup mode:** Press and hold the SET button for 2 seconds, and the STATUS LED will begin flashing.  
 Press the SET button repeatedly until NOR/REV led is lit. Use the rudder stick on your transmitter to select the Servo type: move the stick to left (or right) and STATUS led changes to green, the servo direction is set to NOR.  
 Move the stick to opposite direction and STATUS led changes to red, the servo direction is set to REV.  
 Warning: Flying with reversed gyro will cause the heli to spin out of control. Please double check the direction before attempting to fly the heli.

**6. Rudder Servo Travel Limit Adjustment:** Press and hold the SET button for 2 seconds until the STATUS LED flashes.  
 At this point the rudder servo will be centered. Press the SET button repeatedly until LIMIT led is lit. While observing the heli tail, gradually move the rudder stick on your transmitter left until the tail pitch slider reaches its mechanical end(without binding), then center the rudder stick and wait 2 seconds until STATUS LED flashes red. Now perform the same for right rudder: move the rudder stick on your transmitter right until the tail pitch slider reaches the other end, center the stick and wait 2 seconds for LED to flash again. This will set the travel limit of the servo on both sides. Insufficient rudder servo travel limit will result in decreased rudder performance, while excessive rudder servo travel will overload the rudder servo and cause failures.  
 Caution: Rudder travel setting can not be below 50%, or else GP780 will not register the settings. If excessive travel is observed even after performing the above rudder travel adjustments, please relocate the rudder servo linkage ball closer to the center of servo horn.

**7. Gyro Gain Adjustments:** For radio with GYRO function, gain can be adjusted using this function. The AHTCS (heading lock) gain is set by adjusting the GYRO setting between 50% to 100%, while the normal mode gain is set by adjusting the GYRO setting between 0 to 49%.  
 Actual gain settings will differ amongst different helis and/or servo. The goal is to achieve as high of gain as possible without the tail oscillating (wagging), therefore such adjustment can only be done under actual flight conditions.  
 Suggested initial settings are 70~80% during hover, and 60~70% during idle-up conditions. Gyro gain can be increased or decreased after observing the presence of tail oscillation during flights.  
 Note: For radio systems using 0-100% as gain adjustment under heading lock mode (such as Futaba), the recommended gain setting is approximately 30~35%. For radio system using 50-100% as gain adjustment under heading lock mode (such as JR and Hitec), the recommended gain setting is approximately 70~75%.

**8. helicopter mode and delay setting. These settings incorporates two functions:**  
 (1) GP780 supports mini/micro indoor helicopters. Set the setting based on the appropriate helicopter class.  
 For example: Set the helicopter mode to mini/micro setting (Status LED turns red) for T-Rex 250 and 450; set the helicopter mode to medium/large setting (Status LED turns green) for T-Rex 500/600/700.  
 (2) Slow rudder servos may cause tail oscillation as it receives the faster signal from gyro. If tail oscillation occurs after hard stop from stationary pirouette, increase the gain setting until such oscillation stops.

**Setting Method:** Press and hold the SET button for 2 seconds to enter the setup menu, and select DELAY setting. Push the rudder stick left or right and observe the STATUS LED. RED STATUS represents mini/micro helis such as T-REX250/450, GREEN STATUS represents medium/large helis such as T-REX500/600/700. The amount of delay is set by holding the rudder stick at the position corresponding the delay percentage, 0% at middle stick position (DELAY STATUS LED is flashing) and 100% at the end position, and pressing the SET button to confirm the delay setting.

5. NOR/REV陀螺儀正逆轉開關設定：提起直昇機，將機頭往左擺動，若尾舵伺服器的擺動方向與遙控器的方向舵搖桿打右舵同方向時，表示陀螺儀的動作方向設定正確，若不正確時請更改正逆轉設定。設定方式：持按“SET”鍵2秒進入功能設定模式，選擇NOR/REV選項，以方向舵選擇NOR（STATUS為綠燈）或REV（STATUS為紅燈）。  
 注意：陀螺儀的正逆轉方向設定錯誤時會造成直昇機高速自旋的危險，請務必確認。

6. LIMIT尾舵伺服器行程量調整：持按“SET”鍵2秒進入功能設定模式，此時尾舵伺服器會保持在中立點的位置上，選擇LIMIT選項，接著將方向舵搖桿慢慢的往左移動，使尾控制組達到該側的最大行程限度後，將搖桿回歸中立點不動，待2秒後“STATUS”指示燈會亮紅燈閃爍，表示左側行程量已記憶；接著將尾舵搖桿向右移動至控制組最大行程限度後，再將搖桿回歸中立點不動，待2秒後“STATUS”指示燈亮紅燈閃爍，即完成左右行程量設定，行程量不足時會影響陀螺儀與直昇機的性能，行程量過大易造成伺服器損壞。  
 注意：尾舵行程量設定不可低於50%，否則GP780將不予記憶，若發生行程量設定後，尾控制組仍會超過最大行程，請將尾舵伺服器球頭向內移動，避免行程量不足影響陀螺儀性能。

7. 感度調整：一般具有陀螺儀感度設定功能的遙控器，可直接進入GYRO功能選項進行感度值的設定，設定值50%則陀螺儀的感度為0，設定值50%~100%，則陀螺儀感度值為鎖定狀態的0~100%；設定值50%~0%，則陀螺儀感度值為非鎖定狀態的0~100%。感度值的大小會隨著伺服器與直昇機的不同而有所差異，一般而言，在不產生追蹤現象（直昇機尾部出現左右搖擺的情況）的前提下感度值愈高愈好，所以只能透過實際飛行的狀況來進行調整。  
 進入遙控器感度設定的選項，剛開始停懸時建議先設定在70~80%左右，Idle up飛行時設定在60~70%左右，之後再依實際飛行的狀態再行修正，如果沒有追蹤現象發生時可再調整高感度，若發生追蹤現象時，則調低感度。  
 ※註：鎖定感度值為0~100%的遙控器，如Futaba，建議設定在30~35%左右；鎖定感度值為50~100%的遙控器，如JR、HITEC，建議感度值設定在70~75%左右。

8. 直昇機模式與DELAY控制延遲量調整，此設定結合兩項功能：  
 (1) GP780支援小型/迷你型室內電直，請依直昇機的類型選擇適合的模式，如：T-REX 250/450請選擇小型/迷你型模式（設定時“STATUS”指示燈為紅色）；T-REX500/600/700請選中大型直昇機模式（設定時“STATUS”指示燈為綠色）  
 (2) 使用速度較慢的尾舵伺服器較容易產生追蹤現象，當直昇機停懸時，打方向舵使直昇機快速自轉，當方向舵回到中立點使直昇機停止自轉時，此時若發生追蹤現象，請增加控制延遲的設定量，一般而言在不產生追蹤現象的原則下控制延遲的設定量愈小愈好，否則尾舵的動作會變得遲緩。  
 設定方式：持按“SET”鍵2秒進入功能設定模式，選擇至DELAY選項，以方向舵搖桿選擇小型/迷你型電直如T-REX 250/450（STATUS為紅燈），或中大型直昇機如T-REX500/600/700（STATUS為綠燈），若要同時設定DELAY控制量時，則利用方向舵搖桿的位置來設定，搖桿由中立點推至“DELAY”燈開始閃爍時為0%，推至最大行程時控制量為100%，將搖桿推至所需的延遲量時保持不動，並按下“SET”鍵確認，即可同時設定直昇機模式與延遲量。

## 15. FLIGHT ADJUSTMENT AND SETTING 飛行動作調整與設定

ALIGN











**PLEASE PRACTICE SIMULATION FLIGHT BEFORE REAL FLYING 飛行前請先熟練模擬飛行**

Do a simulation flight until you familiarize your fingers with the movements of the rudders, and keep practicing until the fingers move naturally.

1. Place the helicopter in a clear open field ( Make sure the power OFF ) and the tail of helicopter point to yourself.
2. Practice to operate the throttle stick(as below illustration) and repeat practicing "Throttle high/low", "Aileron left/right", "Rudder left/right", and "Elevator up/down".
3. The simulation flight practice is very important, please keep practicing until the fingers move naturally when you hear operation orders being call out.
4. Another safe and effective practice method is to use the transmitter flying on the computer through simulator software are sold on the market.

在還沒瞭解直昇機各動作的操控方式前，嚴禁通電飛行，請先進行模擬飛行的練習，並不斷的重複，直到手指可熟練的控制各個動作及方向。

1. 將直昇機放在空曠的地方(確認電源為關閉)，並將直昇機的機尾對準自己。
2. 練習操作遙控器的各搖桿(各動作的操作方式如下圖)，並反覆練習油門高/低、副翼左/右、升降舵前/後及方向舵左/右操作方式。
3. 模擬飛行的練習相當重要，請重複練習直到不需思索，手指能自然隨著喊出的指令移動控制。
4. 另外一種最有效、最安全的練習方式，就是透過市面販售的模擬軟體，以遙控器在電腦上模擬飛行，熟悉各種方向的操控。

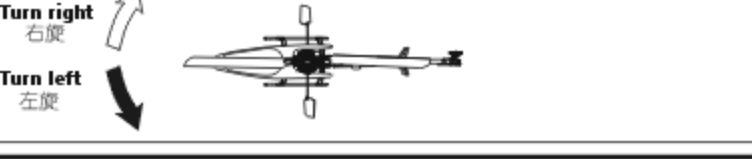
Mode 1	Mode 2	Illustration 圖示
		 <p>Move left 左移</p> <p>Move right 右移</p> <p>Rotate left 左翻</p> <p>Rotate right 右翻</p>
		 <p>Fly forward 前進</p> <p>Fly backward 後退</p> <p>Forward rotate 前翻</p> <p>backward rotate 後翻</p>
		 <p>Ascent 上升</p> <p>Descent 下降</p>
		 <p>Turn right 右旋</p> <p>Turn left 左旋</p>

**FLIGHT ADJUSTMENT AND NOTICE FOR BEGINNERS 初學飛行調整與注意**



- Check if the screws are firmly tightened.
- Check if the transmitter and receivers are fully charged.
- 再次確認→螺絲是否鎖固?
- 發射器和接收器電池是否足夠。



If there are other radio control aircraft at the field, make sure to check their frequencies and tell them what frequency you are using. Frequency interference can cause your model, or other models to crash and increase the risk of danger. 假使飛行場有其他遙控飛機，請確認他們的頻率，並告知他們你正在使用的頻率，相同的頻率會造成干擾導致失控和大大地增加風險。

**★When arriving at the flying field. ★當抵達飛行場**

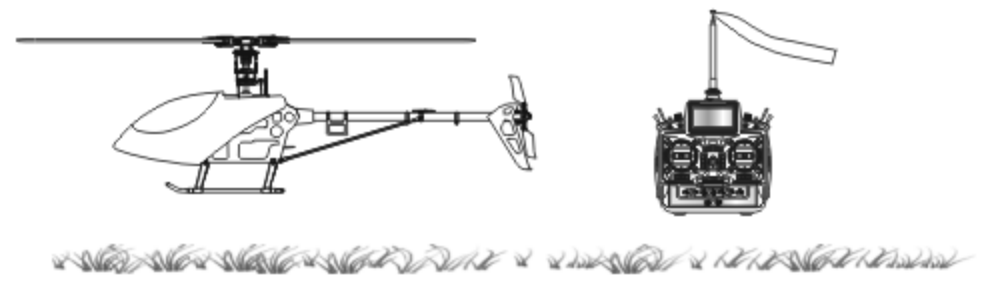

**STARTING AND STOPPING THE MOTOR 啟動和停止馬達**



First check to make sure no one else is operating on the same frequency. Then place the throttle stick at lowest position and turn on the transmitter. 首先確認附近沒有其他相同頻率的使用，然後打開發射器將油門搖桿推到低點。



Check if the throttle stick is set at the lowest position. 確認油門搖桿是在最低的位置。

**★Check the movement. ★動作確認**



**ON! Step 1**  
First turn on the transmitter.  
先開啟發射器



**ON! Step 2**  
Next turn on BEC of the receiver.  
再開啟接收器BEC電源



**ON! Step 3**  
Connect to the power  
接上主動力電源

Mode 1 Mode 2

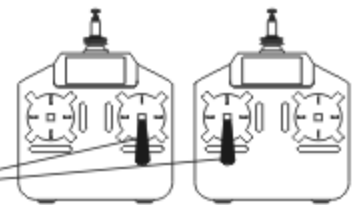

**OFF! Step 4**  
Reverse the above orders to turn off.  
關閉電源時請依上述操作動作反執行。

**Main rotor adjustments 主旋翼雙槳平衡調整**



Tracking adjustment is very dangerous, so please keep away from the helicopter at a distance of at least 10m. 調整軌跡非常危險，請於距離飛機最少10公尺的距離。

- Before adjusting, apply a red piece of tape on one blade, or paint a red stripe with a marker or paint to identify on blade.
- Raise the throttle stick slowly and stop just before the helicopter lifts-off ground. Look at the spinning blades from the side of the helicopter.
- Look at the path of the rotor carefully. If the two blades rotate in the same path, it does not need to adjustment. If one blade is higher or lower than the other blade, adjust the tracking immediately.
- Linkage rod (A): Regular pitch trim (For large variations). Linkage rod (C): Slight pitch trim (For slight variations).

- 調整前先在其中一支主旋翼的翼端，貼上有顏色的貼紙或畫上顏色記號，方便雙槳調整辨識。
- 慢慢的推起油門搖桿到高點並且停止，在飛機離開地面前，從飛機側邊觀察主旋翼轉動。
- 仔細觀察旋翼軌跡(假如兩支旋翼移動都是相同軌跡，則不需要調整;可是如果一支旋翼較高或較低產生“雙槳”的情形時，則必須立刻調整軌跡)。
- 連桿(A)為一般螺距調整(雙槳大時使用)。連桿(C)為螺距微調整(雙槳微幅差異時使用)。

- When rotating, the blade with higher path means the pitch too big. Please lengthen pitch linkage rod (A) for regular trim or shorten linkage rod (C) for slight pitch trim.
- When rotating, the blade with lower path means the pitch too small. Please shorten pitch linkage rod (A) for regular trim or lengthen linkage rod (C) for slight pitch trim.

- 旋翼轉動時較高軌跡的主旋翼表示螺距(PITCH)過大，請調長連桿(A)修正，或需要更小的螺距微調時，請調短連桿(C)修正。
- 旋翼轉動時較低軌跡的主旋翼表示螺距(PITCH)過小，請調短連桿(A)修正，或需要更小的螺距微調時，請調長連桿(C)修正。



Incorrect tracking may cause vibrations. Please repeat adjusting the tracking to make sure the rotor is correctly aligned. After tracking adjustment, please check the pitch angle is approx. +4~5° when hovering. 不正確的旋翼軌跡會導致震動，請不斷重複調整軌跡，使旋翼軌跡精準正確。在調整軌跡後，確認一下pitch角度在停旋時應為大約+4~5°。



**FLIGHT ADJUSTMENT AND NOTICE FOR BEGINNERS 初學飛行調整與注意**



- Make sure that no one or obstructions in the vicinity.
- You must first practice hovering for flying safety. This is a basic flight action. (Hovering means keeping the helicopter in mid air in a fixed position)
- 確認鄰近地區沒有人和障礙物。
- 為了飛行安全，你必須先練習停旋，這是飛行動作的基礎(停旋:直昇機滯留空中並保持固定位置)。

- Please stand approximately 10m diagonally behind the helicopter.
- 練習時，請站在直昇機後方10公尺。

Beginner may install a training landing gear to avoid any crash caused by offset effect while landing. 必要時初學者可以在腳架下方安裝練習架，可避免降落時因重心偏移導致主旋翼或直昇機損毀。

**STEP 1 THROTTLE CONTROL PRACTICE 油門控制練習**

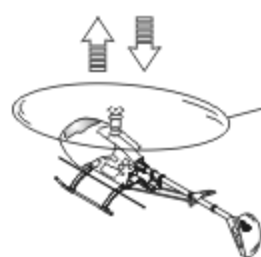
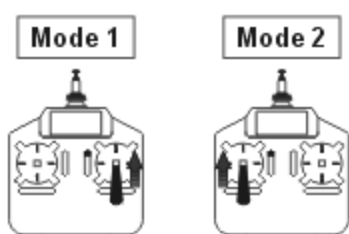

- When the helicopter begins to lift-off the ground, slowly reduce the throttle to bring the helicopter back down. Keep practicing this action until you control the throttle smoothly.
- 當直昇機開始離地時，慢慢降低油門將飛機降下。持續練習飛機從地上升和下降直到你覺得油門控制很順。

## STEP 2 AILERON AND ELEVATOR CONTROL PRACTICE 副翼和升降控制練習

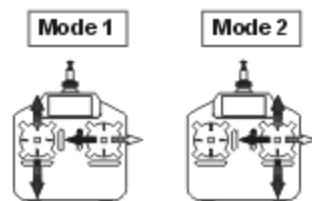

1. Raise the throttle stick slowly.
  2. Move the helicopter in any direction back, forward, left and right, slowly move the aileron and elevator sticks in the opposite direction to fly back to its original position.
1. 慢慢升起油門搖桿。  
2. 使直昇機依指示: 移動向後/向前/向左/向右, 慢慢反向移動副翼和升降搖桿並將直昇機開回到原來位置。

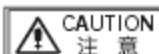
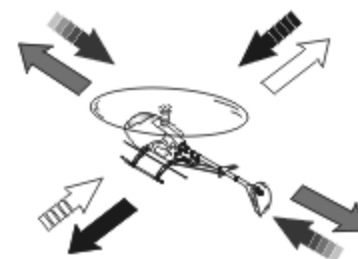

- ⊙ If the nose of the helicopter moves, please lower the throttle stick and land the helicopter. Then move your position diagonally behind the helicopter 10m and continue practicing.
- ⊙ If the helicopter flies too far away from you, please land the helicopter and move your position behind 10m and continue practicing.
- ⊙ 當直昇機機頭偏移時, 請降低油門並且降落, 然後移動自己的位置到直昇機的正後方10公尺再繼續練習。
- ⊙ 假如直昇機飛離你太遠, 請先降落直昇機, 並到直昇機後10公尺再繼續練習。

## STEP 3 RUDDER CONTROL PRACTICING 方向舵操作練習

1. Slowly raise the throttle stick.
  2. Move the nose of the helicopter to right or left, and then slowly move the rudder stick in the opposite direction to fly back to its original position.
1. 慢慢升起油門搖桿。  
2. 將直昇機機頭移動左或右, 然後慢慢反向移動方向舵搖桿並將直昇機飛回原本位置。

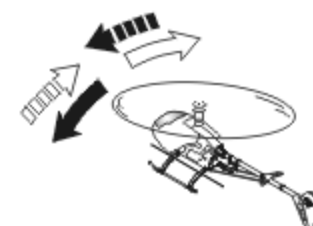
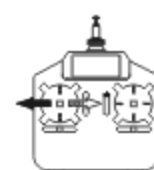

## STEP 4

After you are familiar with all actions from Step1 to 3, draw a circle on the ground and practice within the circle to increase your accuracy.

當你覺得 step1~3 動作熟悉了, 在地上畫圈並在這個圈圈的範圍內練習飛行, 以增加你操控的準確度。

- ⊙ You can draw a smaller circle when you get more familiar with the actions.
- ⊙ 當你更加習慣操作動作, 你可以畫更小的圈。

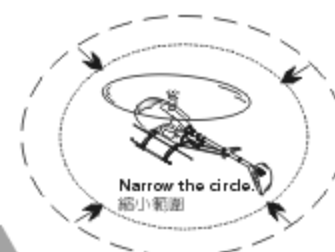

## STEP 5 DIRECTION CHANGE AND HOVERING PRACTICE 改變直昇機方向和練習停旋

After you are familiar with Step1 to 4, stand at side of the helicopter and continue practicing Step1 to 4.

Then repeat the Step1 to 4 by standing right in front of the helicopter.

當你覺得 step1~4 動作熟悉了, 站在面對直昇機側邊並繼續練習 step1~4。之後, 站在直昇機機頭右邊重複步驟練習。

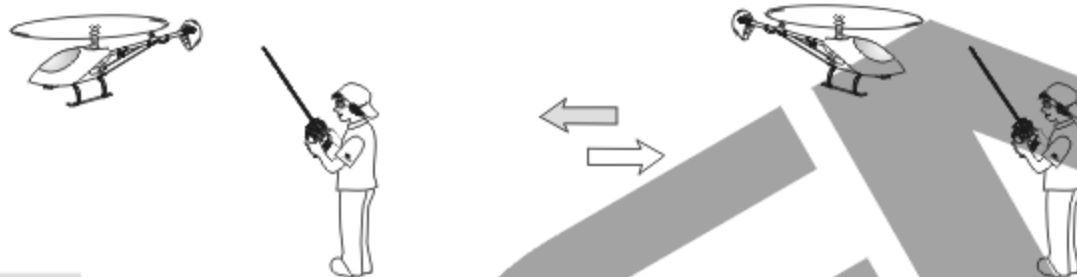

## ADJUSTMENT OF EACH TRIM 飛行動作微調

Slowly raise the throttle stick and just as the helicopter lift-off the ground, you can use the trim to correct the action if the helicopter leans in a different direction.

慢慢升起油門搖桿, 當直昇機剛剛離開地面時, 若直昇機傾向不同方向, 可使用微調修正動作。

### 1. Adjustment of rudder trim 調整方向舵微調

Just before the helicopter lift-off, the nose lean left/right...

When leans right, adjust the trim to left side.

When leans left, adjust the trim to right side.

在直昇機正要起飛時, 機頭朝左/右方向偏移...

向右偏移時, 微調向左調整。

向左偏移時, 微調向右調整。

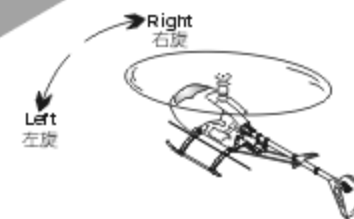
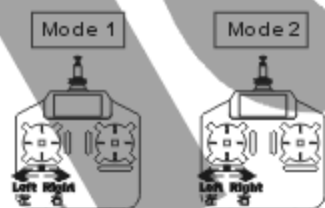

### 2. Adjustment of elevator trim 調整升降舵微調

Just before the helicopter lift-off, the nose lean forward/backward...

When leans forward, adjust the trim down.

When leans backward, adjust the trim up.

在直昇機正要起飛時, 機頭朝前/後方向偏移...

向前偏移時, 微調向下調整。

向後偏移時, 微調向上調整。

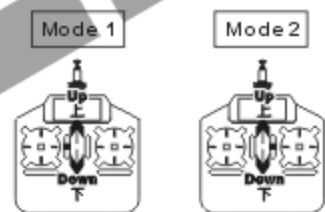

### 3. Adjustment of Aileron trim 調整副翼微調

Just before the helicopter lift-off, the body lean left/right...

When leans right, adjust the trim to left side.

When leans left, adjust the trim to right side.

在直昇機正要起飛時, 機身朝左/右方向偏移...

向右偏移時, 微調向左調整。

向左偏移時, 微調向右調整。

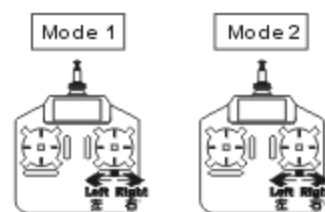

## TROUBLE SHOOTING DURING FLIGHT 如何排除飛行中的狀況

	Situation 狀況	Cause 原因	Way to deal 對策
<b>Blade Tracking 雙槳平衡</b>	Out of tracking 雙槳	Adjustment of pitch rod has not been done. PITCH連桿長度調整不平均	Adjust the length of linkage rod(A)→ Regular trim Adjust the length of linkage rod(C)→ Slight trim 調整連桿(A)長度→一般調整 調整連桿(C)長度→微調整
<b>During Hovering 停旋</b>	Low rotation of the rotor 主旋翼轉速偏低	★ Pitch of main blade is high. ★ 主旋翼的PITCH偏高 ★ Throttle curve is too low during hovering. ★ 停旋點油門曲線過低	★ Lower the pitch about 4~5° during hovering(The rotation should be about 1,600rpm during hovering). ★ 調低Pitch停旋Pitch約4~5°(停旋時主旋翼需為約1600rpm) ★ Heighten the throttle curve during hovering. ★ 調高停旋點油門曲線
	High rotation of the rotor 主旋翼轉速偏高	★ Pitch of main blade is low. ★ 主旋翼的PITCH偏低 ★ Throttle curve is too high during hovering. ★ 停旋點油門曲線過高	★ Adjust the pitch rod(A)(The rotation should be about 1,600rpm during hovering). ★ 調整連桿(A)(停旋時主旋翼需為約1600RPM) ★ Lower the throttle curve during hovering. ★ 調低停旋點油門曲線
<b>Sensitivity of the gyro 陀螺儀敏感度</b>	The tail leans to one side during hovering, or when trim the rudder and return to the neutral, the tail lags and cannot stay in a control position. 停旋時尾翼向某一邊偏移, 或撥動方向舵並回復到中立點時, 尾翼產生延遲, 無法停頓在所控制位置上。	★ Failure setting of tail neutral point. ★ 尾中立點設定不當 ★ The sensitivity of the gyro is low. ★ 陀螺儀敏感度偏低	★ Reset tail neutral point. ★ 重設尾中立點 ★ Increase the sensitivity. ★ 增加敏感度
	The tail wags left and right during flight at hovering or full speed. 停懸或全油門時尾翼左右來回搖擺。	The sensitivity of the gyro is high. 陀螺儀敏感度偏高	Decrease the sensitivity. 降低敏感度

※ If the problem is still there even after tried above, stop flying and contact with your seller.

※ 在做完以上調整後, 仍然無法改善情況時, 應立即停止飛行並連絡您的經銷商。

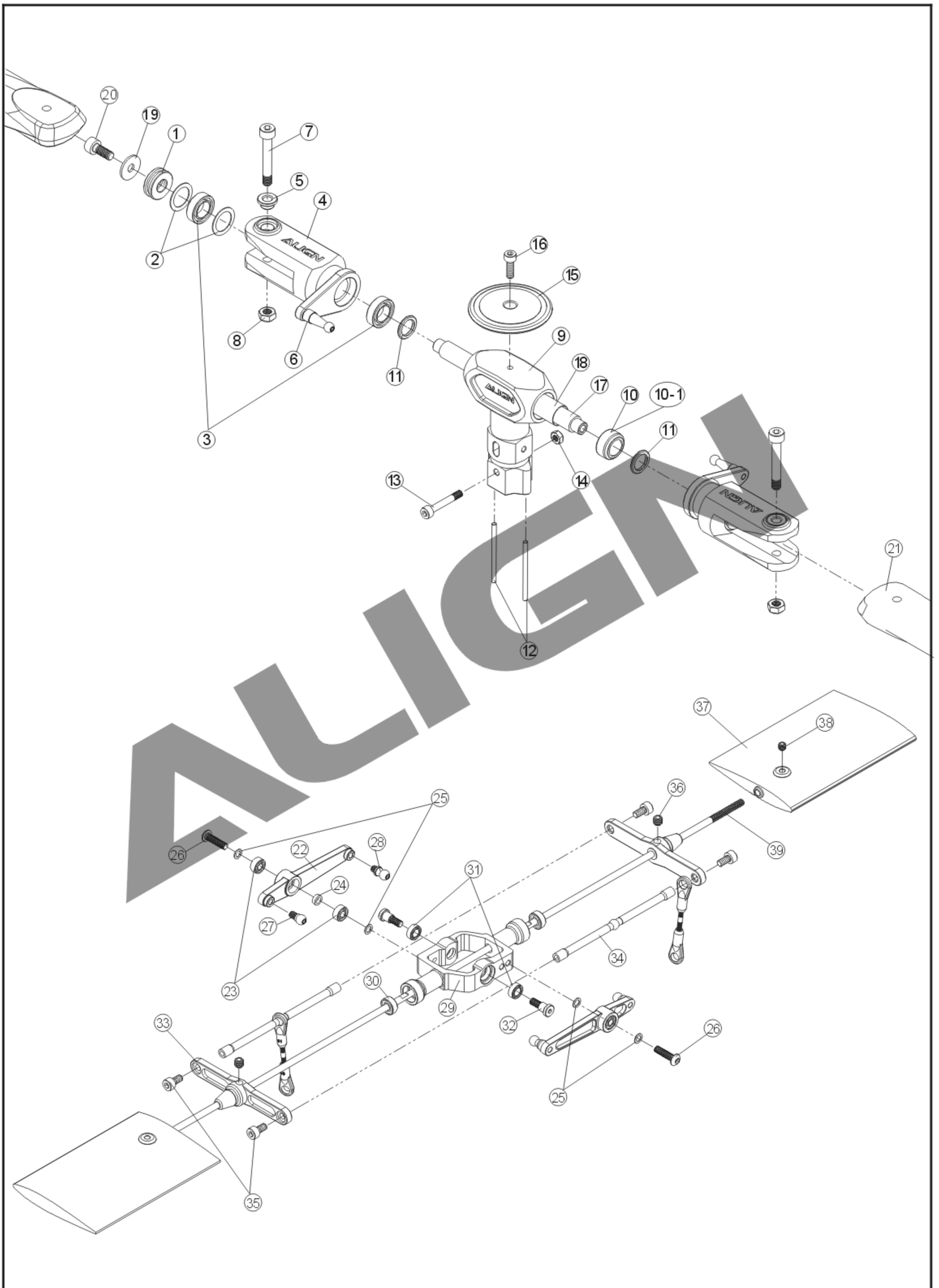



No.	Code No.	Name	Specification	Quantity	Remarks
1	50H009	Thrust bearing 止推軸承	φ 6x φ 14x5mm	2	
2	50H008-1	Spindle bearing spacer 橫軸軸承墊片	φ 10x φ 13.8x0.4mm	4	
3	50HMR148ZZ	Bearing 軸承	φ 8x φ 14x4mm	4	
4	50NH007	Metal main rotor holder 金屬主旋翼夾座		2	
5	50H011	Collar 金屬主旋翼夾座襯套	φ 4x φ 6x φ 9x4.3mm	2	
6	50NH006	Linkage ball F(M3.5x4) 球頭F (M3.5x4)	φ 4.75x20.25mm	2	
7	T64027	Socket collar screw 圓頭內六角軸套螺絲	M4x27mm	2	
8	N14001	M4 Nut M4防鬆螺帽	M4	2	
9	50H001	Metal main rotor housing 金屬主旋翼固定座		1	
10	50NH008	Damper rubber-black 85° 橫軸墊圈-黑85°	φ 7.9x φ 13x6.5mm	2	
10-1	50NH013	Damper rubber-gray 70° 橫軸墊圈-灰70°	φ 7.9x φ 13x6.5mm	2	
11	50H006	Spacer 橫軸套圈	φ 8x φ 11.5x1.3mm	2	
12	50H136	Pin 定位插銷	φ 2x32mm	2	
13	T63022	Socket collar screw 圓頭內六角軸套螺絲	M3x22mm	1	
14	N10030	M3 Nut M3防鬆螺帽	M3	1	
15	50H164-1	Metal head stopper 金屬旋翼頭制動器		1	
16	T63010	Socket screw 圓頭內六角螺絲	M3x10mm	1	
17	50H003-2	Feathering shaft 橫軸	φ 6x φ 8x93.2mm	1	
18	50NH003	Feathering shaft sleeve 橫軸支撐套	φ 8x φ 10x31mm	1	
19	50H010	Washer 橫軸華司	φ 4x φ 12x1mm	2	
20	T64010	Socket screw 圓頭內六角螺絲	M4x10mm	2	
21	KU110010	600D Carbon Fiber Blades/3K 600D碳纖主旋翼/3K		1 set	
22	50H162-2	Metal SF Mixing arm 金屬SF控制搖臂		2	
23	50H683ZZ	Bearing 軸承	φ 3x φ 7x3mm	4	
24	50H024	Collar 擺臂軸承襯套	φ 3x φ 4.8x1.5mm	2	
25	50H022-2	Washer 華司	φ 3x φ 4.8x0.3mm	4	
26	T53012-1	Socket button head screw 半圓頭內六角螺絲	M3x12mm	2	
27	50H042-1	Linkage ball A(M3x4) 球頭A (M3x4)	φ 4.75x8.68mm	2	
28	50H044	Linkage ball B(M3x3) 球頭B (M3x3)	φ 4.75x9.77mm	2	
29	50H019-1	Metal flybar seesaw holder 金屬平衡桿固定座		1	
30	50TMR83ZZ	Bearing 軸承	φ 3x φ 8x3mm	2	
31	50HMR74ZZ	Bearing 軸承	φ 4x φ 7x2.5mm	2	
32	50H119-2	M3 collar screw M3雙層軸套螺絲	M3x9.6mm	2	
33	50NH002	Metal flybar control arm 金屬平衡翼控制臂	φ 3.4x74.2mm	2	
34	50H018-1	Flybar control rod 平衡翼球型控制球桿		2	
35	T63005	Socket screw 圓頭內六角螺絲	M3x5mm	4	
36	T74004	M4 Set screw M4止洩螺絲	M4x4mm	2	
37	50NH011	Carbon fiber flybar paddle/3K 碳纖平衡翼/3K		1 set	
38	T73004	M3 Set screw M3止洩螺絲	M3x3mm	4	
39	50H033	Flybar rod 平衡翼桿	φ 3x440mm	1	

**Specifications, contents of parts and availability are subject to change, Align RC is not responsible for inadvertent errors in this publications.**  
 本說明書內的材質、規格或零件包裝之內容物僅供參考。本公司將不對此印刷物之異動負責，也無法主動通知消費者，任何更新或異動，請以亞拓網頁為主。

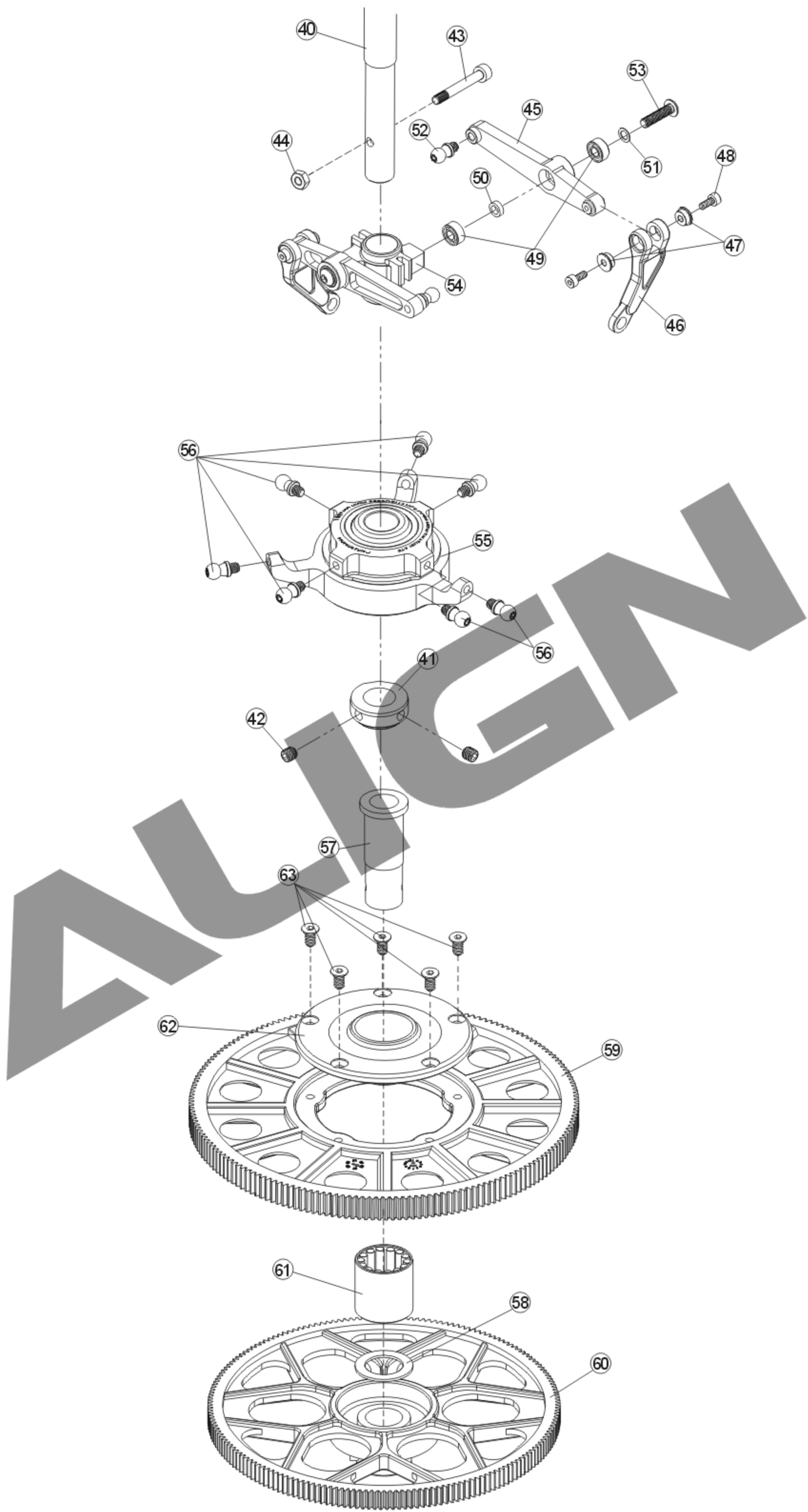

No.	Code No.	Name	Specification	Quantity	Remarks
40	50H232	Main shaft 主軸	φ 10x192mm	1	
41	50H045-1	Lock collar 主軸固定環	φ 10x φ 15x7mm	1	
42	T74004	M4 Set screw M4止洩螺絲	M4x4mm	2	
43	T63020	Socket collar screw 圓頭內六角軸套螺絲	M3x20mm	1	
44	N10030	M3 Nut M3防鬆螺帽	M3	1	
45	50H161-2	Metal washout control arm 金屬穩定控制搖臂		2	
46	50H218	Radius arm 新Radius連桿		2	
47	HFMR52ZZ-1	Bearing 軸承	φ 2x φ 5x2.3mm	4	
48	T52005	Socket screw 圓頭內六角螺絲	M2x5mm	4	
49	50H683ZZ	Bearing 軸承	φ 3x φ 7x3mm	4	
50	50H024	Collar 擺臂軸承襯套	φ 3x φ 4.8x1.5mm	2	
51	50H022-2	Washer 華司	φ 3x φ 4.8x0.3mm	2	
52	50H044	Linkage ball B(M3x3) 球頭B(M3x3)	φ 4.75x9.77mm	2	
53	T53012-1	Socket button head screw 半圓頭內六角螺絲	M3x12mm	2	
54	50NH004	Metal washout base 金屬向位器		1	
55		CCPM Metal Swashplate 金屬CCPM十字盤組		1	
56	50H044	Linkage ball B(M3x3) 球頭B(M3x3)	φ 4.75x9.77mm	7	
57	50B048-3	One-way bearing shaft 單向軸承套	φ 9x φ 12x34.55mm	1	
58	50B050	Washer 單向軸承華司	φ 11.5x φ 18x0.8mm	1	
59	50B158-1	Main drive gear(170T) 主齒盤(170T)	170T	1	
60	50B054-1	Autorotation tail drive gear(180T) 尾驅動主齒(180T)	180T	1	
61	50B049-1	One-way bearing 單向軸承	φ 12x φ 18x16mm	1	
62	50B051-3	Main gear case 主齒中心座	φ 55x14.5mm	1	
63	S83007	Hex socket self tapping screw 圓頭內六角自攻螺絲	T3x7mm	5	

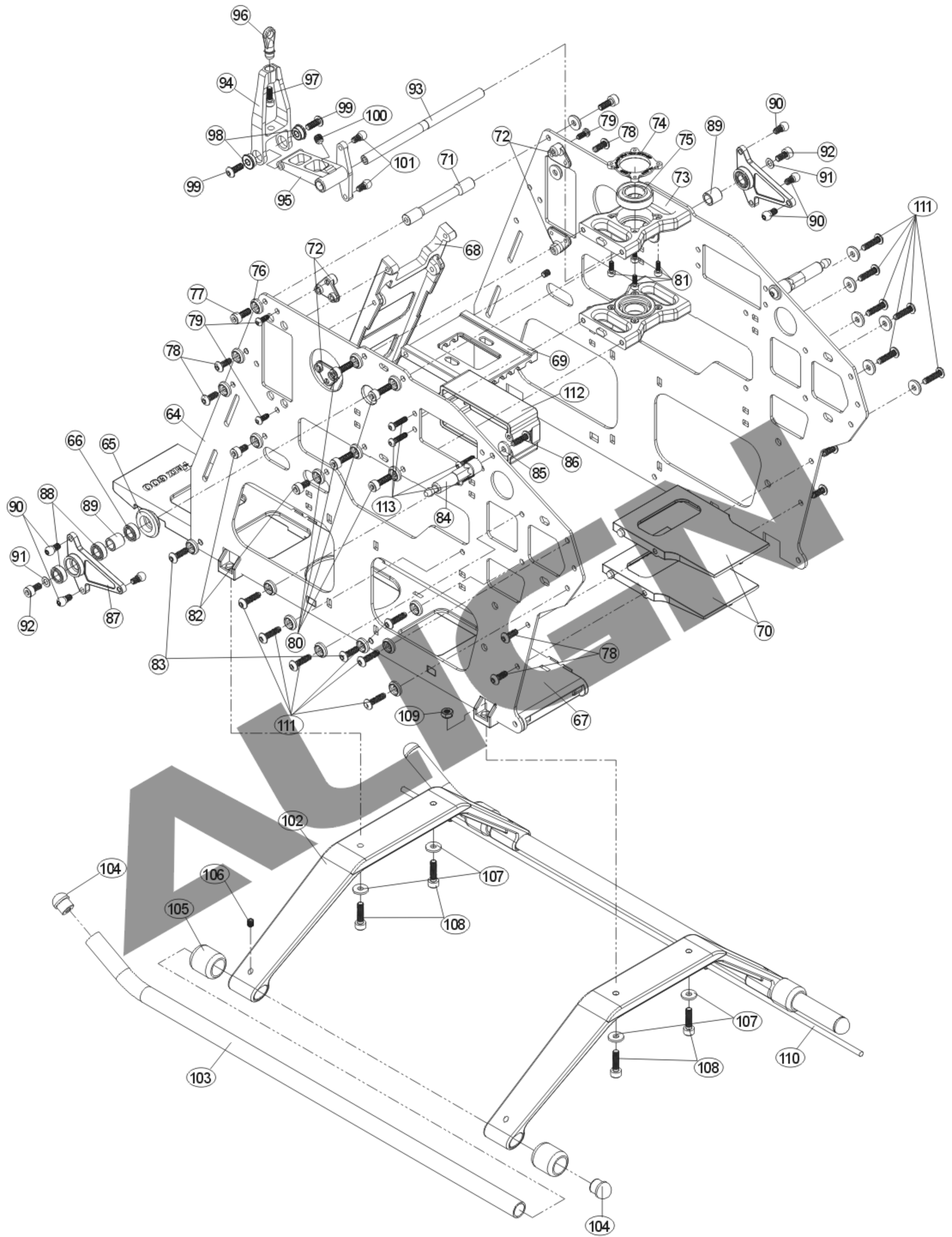

No.	Code No.	Name	Specification	Quantity	Remarks
64	50B226	Carbon fiber main frame 碳纖主體側板	284.98x186.4x1.6mm	2	
65	50B060	Bearing mount 控制臂軸承座	φ 9x φ 15x4.5mm	2	
66	50BMR95ZZ	Bearing 軸承	φ 5x φ 9x5mm	2	
67	50B073-1	Bottom bracket 主體底板	53x289.94x12mm	1	
68	50B064	Battery mount 電池固定座		1	
69	50B063	Motor mount 馬達固定座		1	
70	50B074-1	Gyro mount 陀螺儀固定座	70x47x5mm	2	
71	50B138	Frame mounting bolt 機身鋁柱		1	
72	90NB015	Servo mounting plate 伺服器固定片		4	
73	50B216	Metal main shaft block 金屬主軸固定座	47x34x8mm	2	
74	50B217	Metal main shaft clamp ring 金屬主軸固定蓋	φ 16x φ 21.5x2mm	2	
75	50B6800-2	Bearing 軸承	φ 10x φ 19x5mm	2	
76	50B072	M3 Specialty washer M3特殊華司	φ 3x φ 8x2mm	34	
77	T63008	Socket screw 圓頭內六角螺絲	M3x8mm	2	
78	S93008	Socket button head self tapping screw 半圓頭內六角自攻螺絲	T3x8mm	8	
79	S92606	Socket button head self tapping screw 半圓頭內六角自攻螺絲	T2.6x6mm	4	
80	T63010	Socket screw 圓頭內六角螺絲	M3x10mm	8	
81	T62006	Socket screw 圓頭內六角螺絲	M2x6mm	8	
82	T63006	Socket screw 圓頭內六角螺絲	M3x6mm	4	
83	S93010	Socket button head self tapping screw 半圓頭內六角自攻螺絲	T3x10mm	4	
84	50B121	Canopy mounting bolt 機頭罩固定柱		2	
85	W10030	M3 Washer M3華司	φ 3x φ 8x1mm	2	
86	S93010	Socket button head self tapping screw 半圓頭內六角自攻螺絲	T3x10mm	2	
87	50B239	Metal aileron lever 金屬左右控制搖臂		2	
88	50BMR95ZZ	Bearing 軸承	φ 5x φ 9x5mm	4	
89	50B240	Control shaft collar 連動桿套圈	φ 5x φ 7x7mm	2	
90	50H042-1	Linkage ball A(M3x4) 球頭A(M3x4)	φ 4.75x8.68mm	6	
91	50H022	Washer 華司	φ 3x φ 5.5x0.3mm	2	
92	T63006	Socket screw 圓頭內六角螺絲	M3x6mm	2	
93	50B233	Control shaft 連動桿	φ 5x85mm	1	
94	50B236	Elevator arm 升降控制臂		1	
95	50B237	Elevator lever 升降連動控制臂		1	
96	50B238	Elevator ball link 升降臂連桿頭		1	
97	T62508	Socket screw 圓頭內六角螺絲	M2.5x8mm	1	
98	HF683ZZ	Bearing 軸承	φ 3x φ 7x3mm	2	
99	T53006	Socket button head screw 半圓頭內六角螺絲	M3x6mm	2	
100	T74004	M4 Set screw M4止洩螺絲	M4x4mm	1	
101	50H042-1	Linkage ball A(M3x4) 球頭A(M3x4)	φ 4.75x8.68mm	2	
102	50F179	Landing skid 腳架		2	
103	50F083	Skid pipe 腳架鋁管	φ 9x310mm	2	
104	50F084	Skid pipe end cap 腳架鋁管保護套		4	
105	50F130	Landing skid nut 腳架墊圈		4	
106	T73004	M3 Set screw M3止洩螺絲	M3x4mm	4	
107	W10030	M3 Washer M3華司	φ 3x φ 8x1mm	4	
108	T63012	Socket screw 圓頭內六角螺絲	M3x12mm	4	
109	N10030	M3 Nut M3防鬆螺帽	M3	4	
110	50F128	Antenna pipe 天線管	φ 2x φ 4x500mm	1	
111	S93012	Socket button head self tapping screw 半圓頭內六角自攻螺絲	T3x12mm	8	
112		Elevator servo mount 升降伺服器座		1	
113	S92608	Socket button head self tapping screw 半圓頭內六角自攻螺絲	T2.6x8mm	4	

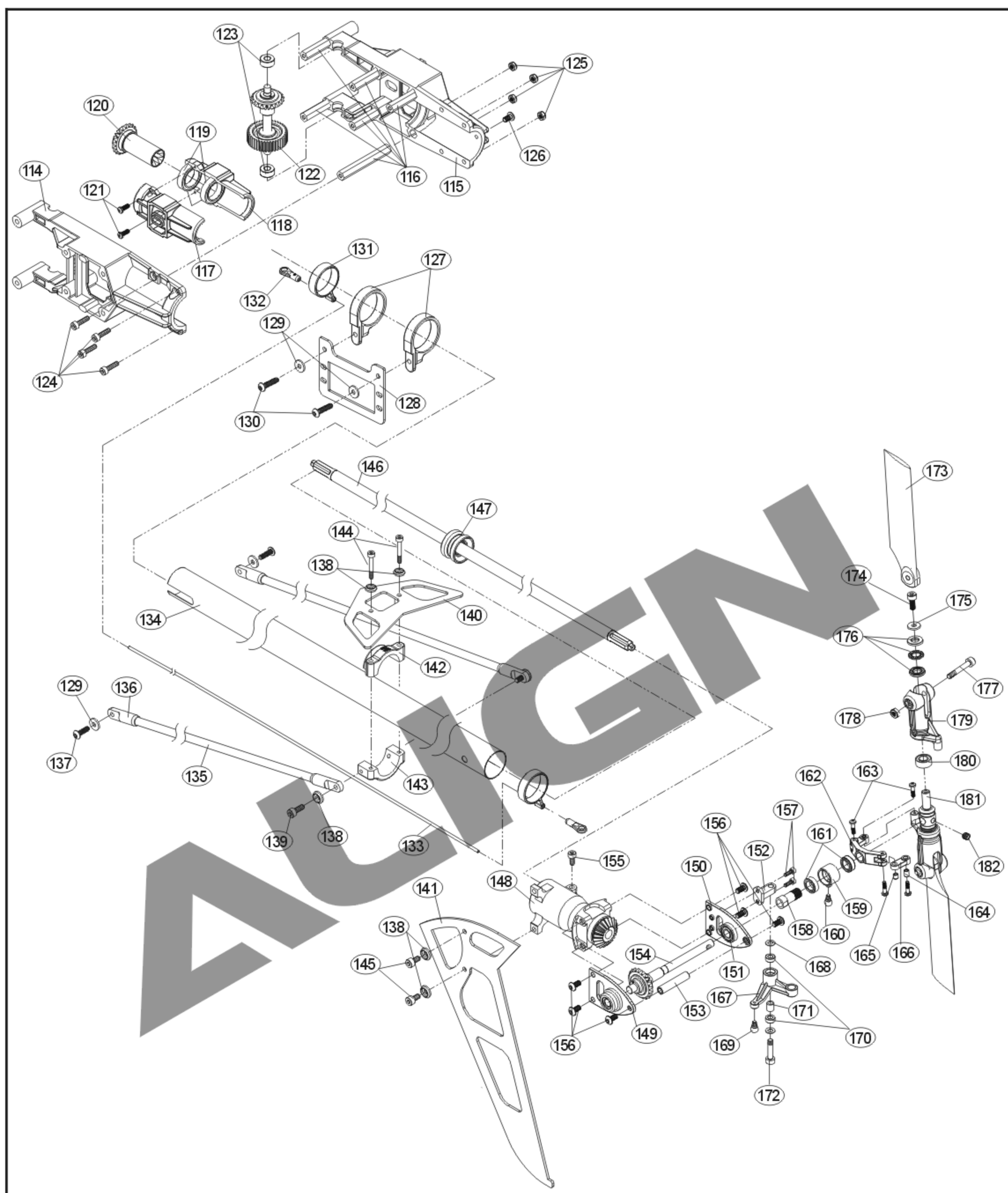

No.	Code No.	Name	Specification	Quantity	Remarks
114	50B076-2	Tail boom mount (L)	尾管固定座(左)	1	
115	50B075-2	Tail boom mount (R)	尾管固定座(右)	1	
116	50B077	Hexagonal bolt	六角柱	6	
117	50T199	Umbrella gear case (L)	傘齒左固定座	φ 15.5x φ 19x52.5mm	1
118	50T200	Umbrella gear case (R)	傘齒右固定座	φ 15.5x φ 19x52.5mm	1
119	50T6701ZZ	Bearing	軸承	φ 12x φ 18x4mm	2
120	50T194	Front umbrella gear	前軸傳傘型齒	φ 21.2x33.6mm	1
121	T52008-1	Socket button head self tapping screw	半圓頭內六角自攻螺絲	T2x8mm	2

No.	Code No.	Name	Specification	Quantity	Remarks
122		Front drive gear assembly 尾傳動導輪軸組		1	
123	50B684ZZ	Bearing 軸承	φ 4x φ 9x4mm	2	
124	T63008	Socket screw 圓頭內六角螺絲	M3x12mm	4	
125	N10030	M3 Nut M3防鬆螺帽	M3	4	
126	T53005-1	Socket button head screw 半圓頭內六角螺絲	M3x5mm	1	
127	50T086	Rudder servo mount 尾舵伺服器座		2	
128	50T087	Rudder servo bracket 尾舵伺服器板		1	
129	W10030	Washer M3華司	φ 3x φ 8x1mm	4	
130	S93012	Socket button head self tapping screw 半圓頭內六角自攻螺絲	T3x12mm	2	
131	50T125-1	Tail control guide 尾控制桿固定環		2	
132	50Z124	Ball link 連桿頭		2	
133	50T133-4	Rudder control rod 尾舵控制連桿	φ 1.96x563mm	1	
134	50T085	Tail boom 尾管	φ 20.3x φ 21.5x625mm	1	
135	50T132	Tail boom brace 尾管支撐架	φ 5x460mm	2	
136	50T123	Tail boom brace end 尾管支撐架接頭		4	
137	S93014	Socket button head self tapping screw 半圓頭內六角自攻螺絲	T3x14mm	2	
138	50B072	M3 Specialty washer M3特殊華司	φ 3x φ 8x2mm	6	
139	T63008	Socket screw 圓頭內六角螺絲	M3x8mm	2	
140	50T167-1	3K CF Horizontal stabilizer 3K碳纖水平翼		1	
141	50T166-2	3K CF Vertical stabilizer 3K碳纖垂直翼		1	
142	90NT025	Metal stabilizer mount(Upper) 金屬水平翼固定座(上)		1	
143	50T108-2	Metal stabilizer mount(Lower) 金屬水平翼固定座(下)		1	
144	T63022	Socket collar screw 圓頭內六角軸套螺絲	M3x22mm	2	
145	T63010	Socket screw 圓頭內六角螺絲	M3x10mm	2	
146	50T188	Torque tube set 尾傳動軸桿	φ 6.7x φ 8x653mm	1	
147	50T193	Torque tube bearing holder 尾傳動軸承墊圈	φ 14x φ 20.7x13mm	1	
148		Metal tail unit set 金屬尾軸傳固定座組		1	
149	50T182	Metal plate(L) 金屬尾軸傳座左側板		1	
150	50T183	Metal plate(R) 金屬尾軸傳座右側板		1	
151	50TMR105ZZ	Bearing 軸承	φ 5x φ 10x4mm	2	
152	50T185	Control arm mounting bolt 軸傳尾控制臂固定座		1	
153	50T192	Aluminum bolt 尾齒箱鋁柱	φ 4.98x24mm	1	
154		Tail rotor shaft assembly 軸傳尾橫軸組		1	
155	T63008	Socket screw 圓頭內六角螺絲	M3x8mm	1	
156	T53006	Socket button head screw 半圓頭內六角螺絲	M3x6mm	6	
157	T52005	Socket screw 圓頭內六角螺絲	M3x5mm	2	
158	50T101-3	Slide Shaft 尾軸滑套	φ 5x φ 7.2x16.7mm	1	
159	50T102-2	Bearing holder 尾翼控制組軸承座		1	
160	50H144-1	Linkage ball A(T2.6x3.5) 球頭A(T2.6x3.5)	φ 4.75x8.18mm	1	
161	50T106ZZ	Bearing 軸承	φ 6x φ 10x3mm	2	
162	50T111	Metal T type arm 金屬尾翼控制組T型臂		1	
163	T12008-4	Collar screw 軸套螺絲	M2x8mm	4	
164	50T106	Collar A 尾連桿銅套A	φ 2x φ 3x4mm	2	
165	50T127	Collar B 尾連桿銅套B	φ 2x φ 3x3mm	2	
166	50T105-1	Control link 尾控制連桿頭		2	
167	50T096-1	Tail rotor control arm 尾旋翼控制臂		1	
168	50H022-2	Washer 華司	φ 3x φ 4.8x0.3mm	2	
169	50H144-1	Linkage ball A(T2.6x3.5) 球頭A(T2.6x3.5)	φ 4.75x8.18mm	1	
170	HMR63ZZ	Bearing 軸承	φ 3x φ 6x2.5mm	2	
171	50T097	Collar 尾旋翼控制臂鋁套	φ 3x φ 4.9x5mm	1	
172	T63015	Socket collar screw 圓頭內六角軸套螺絲	M3x15mm	1	
173	50T203H	3K CF Tail blade 3K碳纖尾旋翼		1set	
174	T63008	Socket screw 圓頭內六角螺絲	M3x8mm	2	
175	W10030-1	Washer 華司	φ 3x φ 8x1mm	2	
176	50TF510M	Thrust bearing 止推軸承	φ 5x φ 10x4mm	2	
177	T63020	Socket collar screw 圓頭內六角軸套螺絲	M3x20mm	2	
178	N10030	M3 Nut M3防鬆螺帽	M3	2	
179	50T171	Tail rotor holder 尾旋翼夾座		2	
180	50TMR105ZZ-1	Bearing 軸承	φ 5x φ 10x4mm	2	
181	50T172	Tail rotor hub 尾旋翼T型座	φ 10x39.6mm	1	
182	T74004	M4 Set screw M4止洩螺絲	M4x4mm	1	

**Specifications & Equipment/規格配備:**

Length/機身長: 1160mm(45.67 in)

Height/機身高: 400mm(15.75 in)

Main Blade Length/主旋翼長: 600mm

Main Rotor Diameter/主旋翼直徑: 1350mm(53.15 in)

Tail Rotor Diameter/尾旋翼直徑: 240mm(9.45 in)

Motor Pinion Gear/馬達主齒: 14T(15T optional)

Main Drive Gear/傳動主齒輪: 170T

Autorotation Tail Drive Gear/尾驅動主齒: 180T

Tail Drive Gear/尾翼傳動齒: 40T

Drive Gear Ratio/齒輪傳動比: 1:12.14:4.5/1:11.33:4.5

Weight(w/o main blade)/空機重: 2450g(5.4 lbs)

Flying Weight/全配重: Approx. 3300g(7.3 lbs)

