

TREX 600EFL PRO Kit

ALIGN

INSTRUCTION MANUAL

使用說明書

KX016018T



Contents

1	INTRODUCTION 前言
1~2	SAFETY NOTES 安全注意事項
3	EQUIPMENT REQUIRED FOR ASSEMBLY 自備設備
3	PACKAGE ILLUSTRATION 包裝說明
4	SAFETY CHECK BEFORE FLYING 飛行前安全檢查重要事項
5~16	ASSEMBLY SECTION 組裝說明
17	BATTERY INSTALLATION ILLUSTRATION 電池安裝示意圖
17	EQUIPMENT INSTALLATION 各項設備配置圖
18	INSTALLATION FOR ESC AND BEC 無刷調速器與BEC安裝
18	CANOPY ASSEMBLY 機頭罩安裝
19	ELECTRIC EQUIPMENT ILLUSTRATION 電子設備建議配置圖示
20	ADJUSTMENTS FOR GYRO AND TAIL NEUTRAL SETTING 陀螺儀與尾翼中立點調整
21	PITCH AND THROTTLE SETTING 主旋翼螺距與油門設定
22	RCM-BL600MX 510KV POWER COLLOCATION REFERENCE 原裝動力數據參考表
23~26	FLIGHT ADJUSTMENT AND SETTING 飛行動作調整與設定
26	SETUP EXAMPLES 飛行特性設定對照表

Thank you for buying ALIGN products. The **T-REX 600EFL Pro** is the latest technology in Rotary RC models. Please read this manual carefully before assembling and flying the new **T-REX 600EFL Pro** helicopter. We recommend that you keep this manual for future reference regarding tuning and maintenance.

承蒙閣下選用亞拓遙控世界系列產品，謹表謝意。進入遙控世界之前必須告訴您許多相關的知識與注意事項，以確保您能夠在學習的過程中較得心應手。在開始操作之前，請務必詳閱本說明書，相信一定能夠給您帶來相當大的幫助，也請您妥善保管這本說明書，以作為日後參考。

Thank you for buying ALIGN Products. The T-REX 600EFL Pro Helicopter is designed as an easy to use, full featured Helicopter R/C model capable of all forms of rotary flight. Please read the manual carefully before assembling the model, and follow all precautions and recommendations located within the manual. Be sure to retain the manual for future reference, routine maintenance, and tuning.

The T-REX 600EFL Pro is a new product developed by ALIGN. It provides flying stability for beginners, full aerobatic capability for advanced fliers, and unsurpassed reliability for customer support.

感謝您選購亞拓產品，為了讓您容易方便的使用 T-REX 600EFL Pro 直昇機，請您詳細的閱讀完這本說明書之後再進行組裝以及操作這台直昇機，同時請您妥善的保存這本說明書，作為日後進行調整以及維修的參考。

T-REX 600EFL Pro 是由亞拓自行研發的新產品，不論你是需求飛行穩定性的初學者或是追求性能的飛行愛好者，T-REX 600EFL Pro 將是你最佳的選擇。

WARNING LABEL LEGEND 標誌代表涵義

 WARNING 警告	Mishandling due to failure to follow these instructions may result in damage or injury. 因為疏忽這些操作說明，而使用錯誤可能造成財產損失或嚴重傷害。
 CAUTION 注意	Mishandling due to failure to follow these instructions may result in danger. 因為疏忽這些操作說明，而使用錯誤可能造成危險。
 FORBIDDEN 禁止	Do not attempt under any circumstances. 在任何禁止的環境下，請勿嘗試操作。

IMPORTANT NOTES 重要聲明

R/C helicopters, including the T-REX 600EFL Pro are not toys. R/C helicopter utilize various high-tech products and technologies to provide superior performance. Improper use of this product can result in serious injury or even death. Please read this manual carefully before using and make sure to be conscious of your own personal safety and the safety of others and your environment when operating all ALIGN products.

Manufacturer and seller assume no liability for the operation or the use of this product. Intended for use only by adults with experience flying remote control helicopters at a legal flying field. After the sale of this product we cannot maintain any control over its operation or usage.

T-REX 600EFL Pro 遙控直昇機並非玩具，它是結合了許多高科技產品所設計出來的休閒用品，所以商品的使用不當或不熟悉都可能造成嚴重傷害甚至死亡，使用之前請務必詳讀本說明書，勿輕忽並注意自身安全。

注意！任何遙控直昇機的使用，製造商和經銷商是無法對使用者於零件使用的損耗異常或組裝不當所發生之意外負任何責任，本產品是提供給有操作過模型直昇機經驗的成人，或有相當技術的人員在旁指導於當地合法遙控飛行場飛行，以確保安全無虞下操作使用。產品售出後本公司將不負任何操作和使用控制上的任何性能與安全責任。

We recommend that you obtain the assistance of an experienced pilot before attempting to fly our products for the first time. A local expert is the best way to properly assemble, setup, and fly your model for the first time. The Helicopter requires a certain degree of skill to operate, and is a consumer item. Any damage or dissatisfaction as a result of accidents or modifications are not covered by any warranty and cannot be returned for repair or replacement. Please contact our distributors for free technical consultation and parts at discounted rates when you experience problems during operation or maintenance.

模型商品屬於需高操作技術且為消耗性之商品，如經拆裝使用後，會造成不等情況零件損耗，任何使用情況所造成商品不良或不滿意，將無法於保固條件內更換新品或退貨，如遇有使用操作維修問題，本公司全省分公司或代理商將提供技術指導、特價零件供應服務。

2. SAFETY NOTES 安全注意事項



Fly only in safe areas, away from other people. Do not operate R/C aircraft within the vicinity of homes or crowds of people. R/C aircraft are prone to accidents, failures, and crashes due to a variety of reasons including, lack of maintenance, pilot error, and radio interference. Pilots are responsible for their actions and damage or injury occurring during the operation or as a result of R/C aircraft models.

遙控模型飛機、直昇機屬高危險性商品，飛行時務必遠離人群，人為組裝不當或機件損壞、電子控制設備不良，以及操控上的不熟悉，都有可能導致飛行失控損傷等不可預期的意外，請飛行者務必注意飛行安全，並需了解自負疏忽所造成任何意外之責任。



LOCATE AN APPROPRIATE LOCATION 遠離障礙物及人群

R/C helicopters fly at high speed, thus posing a certain degree of potential danger. Choose a legal flying field consisting of flat, smooth ground without obstacles.

Do not fly near buildings, high voltage cables, or trees to ensure the safety of yourself, others and your model.

For the first practice, please choose a legal flying field and can use a training skid to fly for reducing the damage. Do not fly your model in inclement weather, such as rain, wind, snow or darkness.

直昇機飛行時具有一定的速度，相對的也潛在著危險性，場地的選擇也相對的重要，請需遵守當地法規到合法遙控飛行場地飛行。

必須注意周遭有沒有人、高樓、建築物、高壓電線、樹木等等，避免操控的不當造成自己與他人財產的損壞。

初次練習時，務必選擇在空曠合法專屬飛行場地並適當搭配練習架練習飛行，這對飛行失誤所造成的損傷將會大幅的降低。請勿在下雨、打雷等惡劣天候下操作，以確保本身及機體的安全。



PREVENT MOISTURE 遠離潮濕環境

R/C models are composed of many precision electrical components.

It is critical to keep the model and associated equipment away from moisture and other contaminants. The introduction or exposure to water or moisture in any form can cause the model to malfunction resulting in loss of use, or a crash. Do not operate or expose to rain or moisture.

直昇機內部也是由許多精密的電子零件組成，所以必須絕對的防止潮濕或水氣，避免在浴室或雨天時使用，防止水氣進入機身內部而導致機件及電子零件故障而引發不可預期的意外！

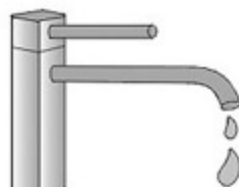

PROPER OPERATION 勿不當使用本產品

Please use the replacement of parts on the manual to ensure the safety of instructors.

This product is for R/C model, so do not use for other purpose.

請勿自行改造加工，任何的升級改裝或維修，請使用亞拓產品目錄中的零件，以確保結構的安全。

請確認於產品限界內操作，請勿過載使用，並勿用於安全、法令外其它非法用途。



OBTAIN THE ASSISTANCE OF AN EXPERIENCED PILOT 避免獨自操控

Before turning on your model and transmitter, check to make sure no one else is operating on the same frequency. Frequency interference can cause your model, or other models to crash.

The guidance provided by an experienced pilot will be invaluable for the assembly, tuning, trimming, and actual first flight.

(Recommend you to practice with computer-based flight simulator.)

至飛行場飛行前，需確認是否有相同頻率的同好正進行飛行，因為開啓相同頻率的發射機將導致自己與他人立即干擾等意外危險。

遙控飛機操控技巧在學習初期有著一定的難度，要盡量避免獨自操作飛行，需有經驗的人士在旁指導，才可以操控飛行。(勤練電腦模擬器及老手指導是入門必要的選擇)

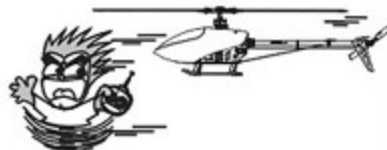

SAFE OPERATION 安全操作

Operate this unit within your ability. Do not fly under tired condition and improper operation may cause in danger.

請於自己能力內及需要一定技術範圍內操作這台直昇機，過於疲勞、精神不佳或不當操作，意外發生風險將可能會提高。



ALWAYS BE AWARE OF THE ROTATING BLADES 遠離運轉中零件

During the operation of the helicopter, the main rotor and tail rotor will be spinning at a high rate of speed. The blades are capable of inflicting serious bodily injury and damage to the environment. Be conscious of your actions, and careful to keep your face, eyes, hands, and loose clothing away from the blades. Always fly the model a safe distance from yourself and others, as well as surrounding objects. Never take your eyes off the model or leave it unattended while it is turned on. Immediately turn off the model and transmitter when you have landed the model.

當直昇機主旋翼與尾旋翼運轉時，切勿觸摸並遠離任何物件，以避免造成危險及損壞。



KEEP AWAY FROM HEAT 遠離熱源

R/C models are made of various forms of plastic. Plastic is very susceptible to damage or deformation due to extreme heat and cold climate. Make sure not to store the model near any source of heat such as an oven, or heater. It is best to store the model indoors, in a climate-controlled, room temperature environment.









遙控飛機多半是以 PA 纖維或聚乙烯、電子商品為主要材質，因此要盡量遠離熱源、日曬，以避免因高溫而變形甚至熔毀損壞的可能。



RADIO TRANSMITTER AND ELECTRONIC EQUIPMENT REQUIRED FOR ASSEMBLY 自備遙控及電子設備

ADDITIONAL TOOLS REQUIRED FOR ASSEMBLY 自備工具

4.PACKAGE ILLUSTRATION 包裝說明

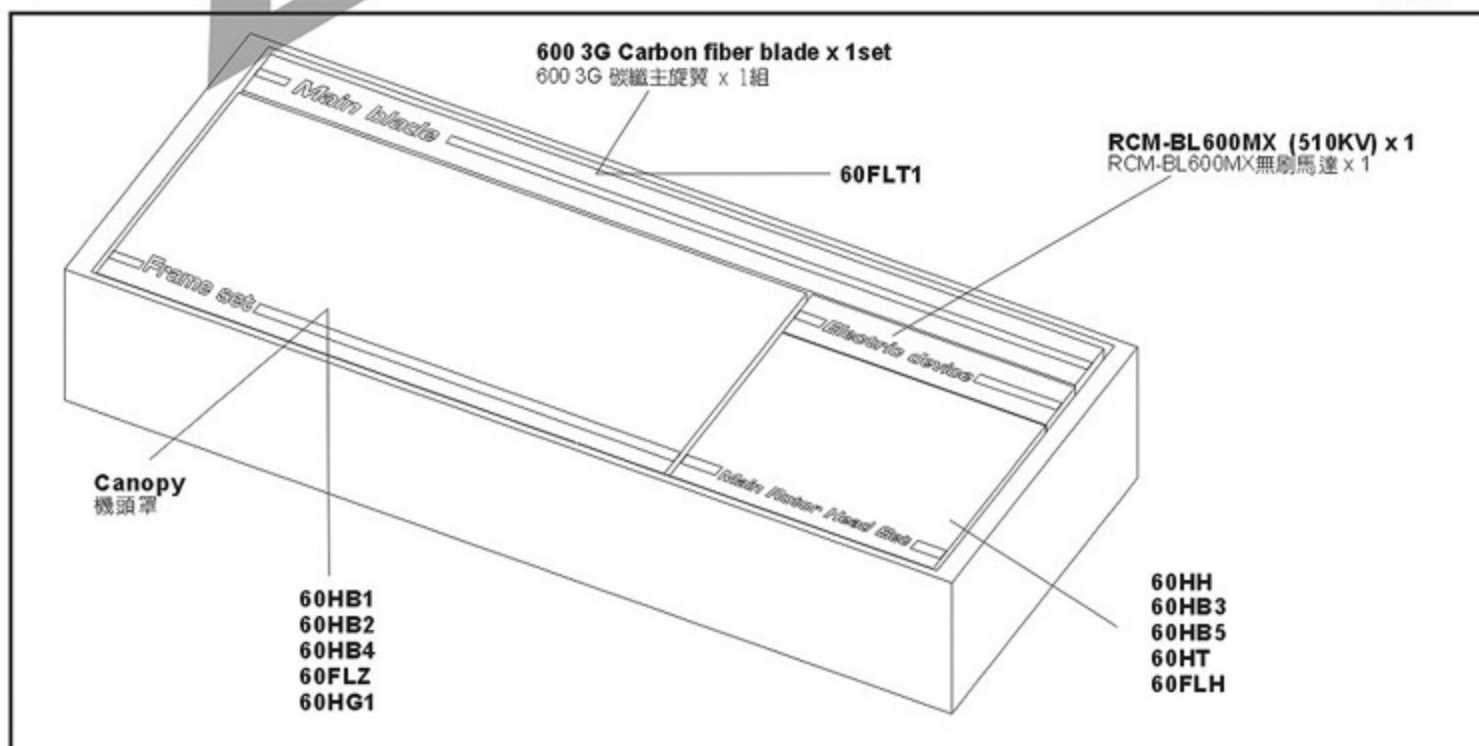

CAREFULLY INSPECT BEFORE REAL FLIGHT 請嚴格執行飛行前之檢查義務

- ☆ Before flying, please check to make sure no one else is operating on the same frequency for the safety.
- ☆ Before flight, please check if the batteries of transmitter and receiver are enough for the flight.
- ☆ Before turn on the transmitter, please check if the throttle stick is in the lowest position. IDLE switch is OFF.
- ☆ When turn off the unit, please follow the power on/off procedure. Power ON- Please turn on the transmitter first, and then turn on receiver. Power OFF- Please turn off the receiver first and then turn off the transmitter. Improper procedure may cause out of control, so please to have this correct habit.
- ☆ Before operation, check every movement is smooth and directions are correct. Carefully inspect servos for interference and broken gear.
- ☆ Check for missing or loose screws and nuts. See if there is any cracked and incomplete assembly of parts. Carefully check main rotor blades and rotor holders. Broken and premature failures of parts possibly cause resulting in a dangerous situation.
- ☆ Check all ball links to avoid excess play and replace as needed. Failure to do so will result in poor flight stability.
- ☆ Check if the battery and power plug are fastened. Vibration and violent flight may cause the plug loose and result out of control.

- ★ 每次飛行前應先確認所使用的頻率是否會干擾他人，以確保你自身與他人的安全。
- ★ 每次飛行前請確認您發射機與接收機電池的電量是在足夠飛行的狀態。
- ★ 開機前請確認油門搖桿是否位於最低點，熄火降落開關，定速開關(IDLE)是否於關閉位置。
- ★ 關機時必須遵守電源開關機的程序，開機時應先開啓發射機後，再開啓接收機電源；關機時應先關閉接收機後，再關閉發射機電源。不正確的開關程序可能會造成失控的現象，影響自身與他人的安全，請養成正確的習慣。
- ★ 開機請先確定直昇機的各個動作是否順暢，及方向是否正確，並檢查伺服器的動作是否有干涉或崩齒的情形，使用故障的伺服器將導致不可預期的危險。
- ★ 飛行前請確認沒有缺少或鬆脫的螺絲與螺帽，確認沒有組裝不完整或損壞的零件，仔細檢查主旋翼是否有損壞，特別是接近主旋翼夾座的部位。損壞或組裝不完整的零件不僅影響飛行，更會造成不可預期的危險。注意：每次飛行前的安全檢查、保養、及更換損耗零件，請確實嚴格執行以確保安全。
- ★ 檢查所有的連桿頭是否有鬆脫的情形，過鬆的連桿頭應先更新，否則將造成直昇機無法操控的危險。
- ★ 確認電池及電源接頭是否固定牢靠，飛行中的震動或激烈的飛行，可能造成電源接頭鬆脫而造成失控的危險。

Standard Equipment 標準配備

 60HC1	 60FLH	 60HB1	 60HB2	 60HB3
 60HB4	 CNC Slant Thread Main Drive Gear CNC主齒輪組 60HB5	 60HT	 60HT1	 60FLT1
 60HG1	 60FLZ	 Motor pinion gear 13T x 1 馬達斜齒輪 13T x 1 M4x4 Set Screw x 2 M4x4 止波螺絲 x 2	 RCM-BL600MX Motor RCM-BL600MX 無刷馬達(610KV)	 600 3G Carbon Fiber Blade 600 3G 碳纖維旋翼 600FLH3

When you see the marks as below, please use glue or grease to ensure flying safety.

標有以下符號之組裝步驟，請配合上膠或上油，以確保使用之可靠度。

CA: Apply CA Glue to fix.
AB: Apply AB Glue to fix.
R48: Apply Anaerobics Retainer to fix.
T43: Apply Thread Lock to fix.
OIL: Add Grease.

CA: 使用瞬間膠固定
AB: 使用AB膠固定
R48: 使用金屬管狀固定缺氣膠固定
T43: 使用螺絲膠
OIL: 添加潤滑油

When assembling ball links, make sure the "A" character faces outside.

各項塑膠製連桿頭扣接時，A字請朝外。



Grease
潤滑油



R48
綠色



T43
藍色



CA
Self-furnished
膠膠(白膠)



AB
Self-furnished
AB膠(白膠)

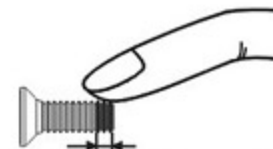

T43 Glue width: approx. 1mm
T43上膠寬度約1mm

R48 metal tubular adhesive (eg. Bearings). T43 thread lock, apply a small amount on screws or metal parts and wipe surplus off. When disassembling, recommend to heat the metal joint about 15 Seconds. (NOTE: Keep plastic parts away from heat.)

R48 為強力金屬管狀(如軸承)接著劑，T43為螺絲膠，膠合螺絲或金屬內外徑請務必少量使用，必要時請用手去除多餘膠量，欲拆卸時可於金屬接合部位熱烤約15秒。(注意！塑膠件避免接近熱源)

60FLH1



60FLH1A

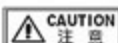

Thrust bearing and washer for radial bearing are wear items, and thus should be inspected for replacement after every 20 flights. For flights with high headspeed, the inspection interval should be reduced to ensure flight safety. 止推軸承及橫軸墊圈屬於飛行消耗品，建議每20趟定期檢查及更換，高主旋翼轉速飛行時，請縮短定期檢查之趟數，以確保飛行安全。

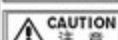

Already assembled by Factory. Before flying, please check if the screws are fixed with glue. 廠家組裝完成品，每一次飛行前請先確認螺絲是否已上膠不會鬆動。

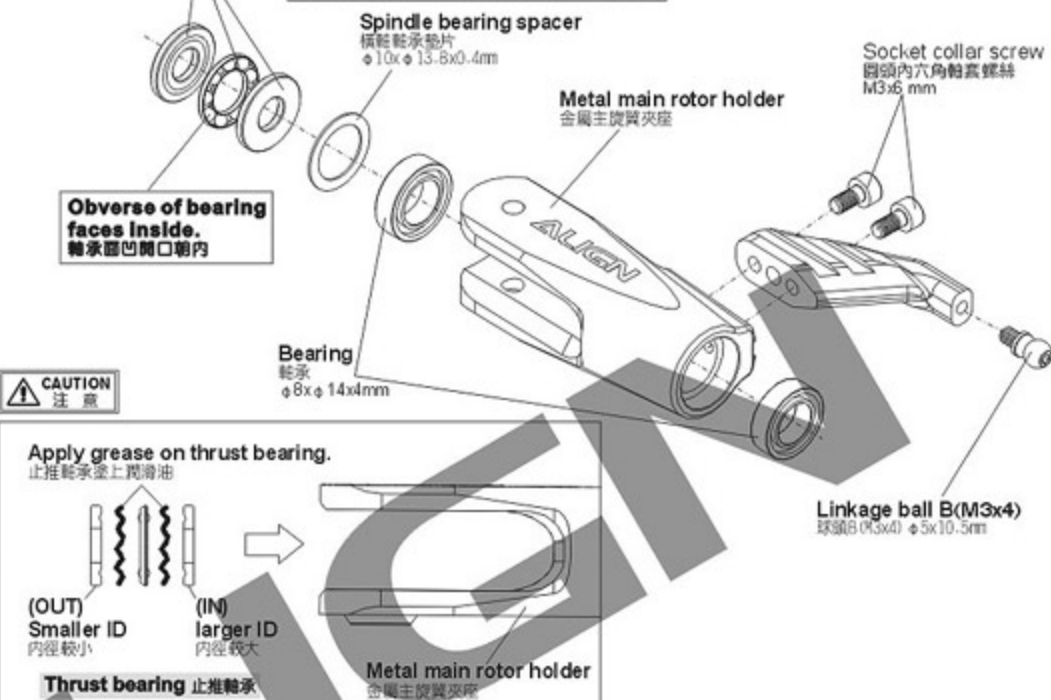

60FLH1

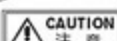
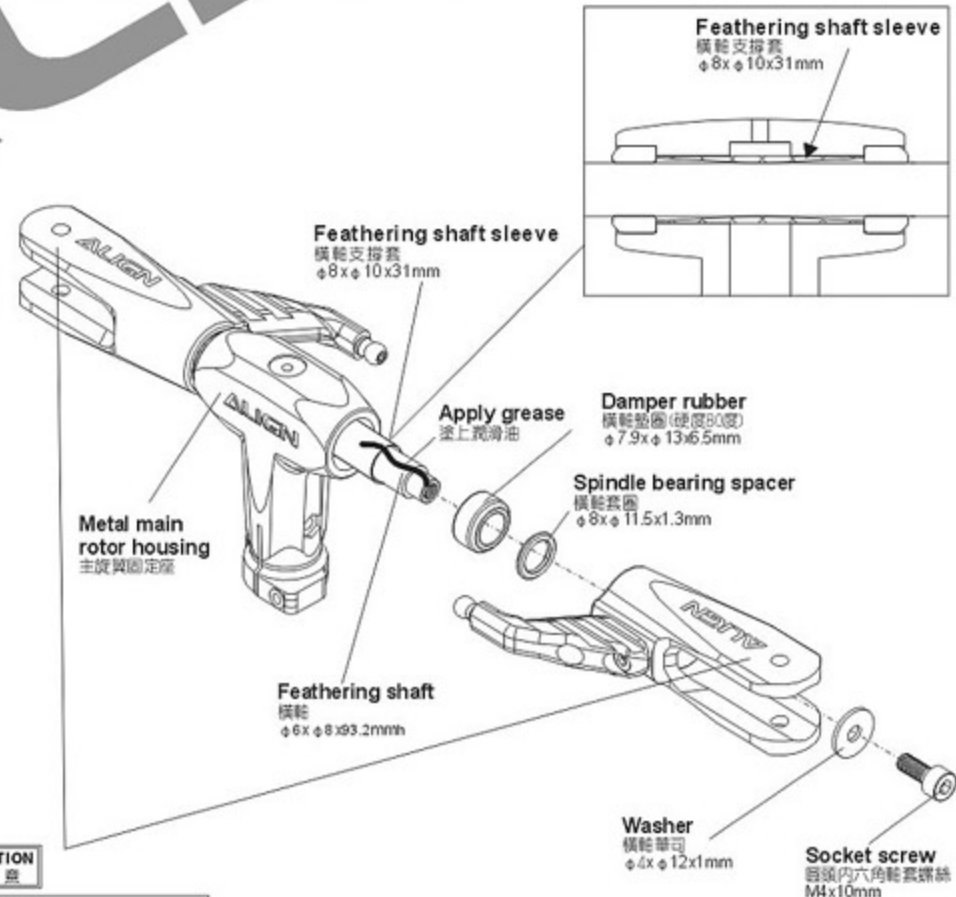
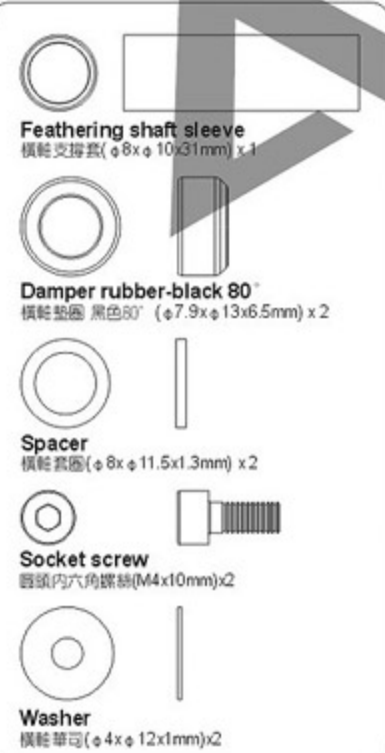

ALIGN logo on the top
字樣朝上

60FLH1



Socket screw
圓頭內六角螺絲(M3x14mm) x 2

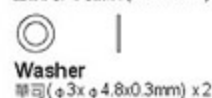

Washer
華司(φ3xφ4.8x0.3mm) x 2



Bearing
軸承(φ3xφ7x35mm) x 4



Collar
擺臂軸承襯套
(φ3xφ4.8x1.5mm) x 2

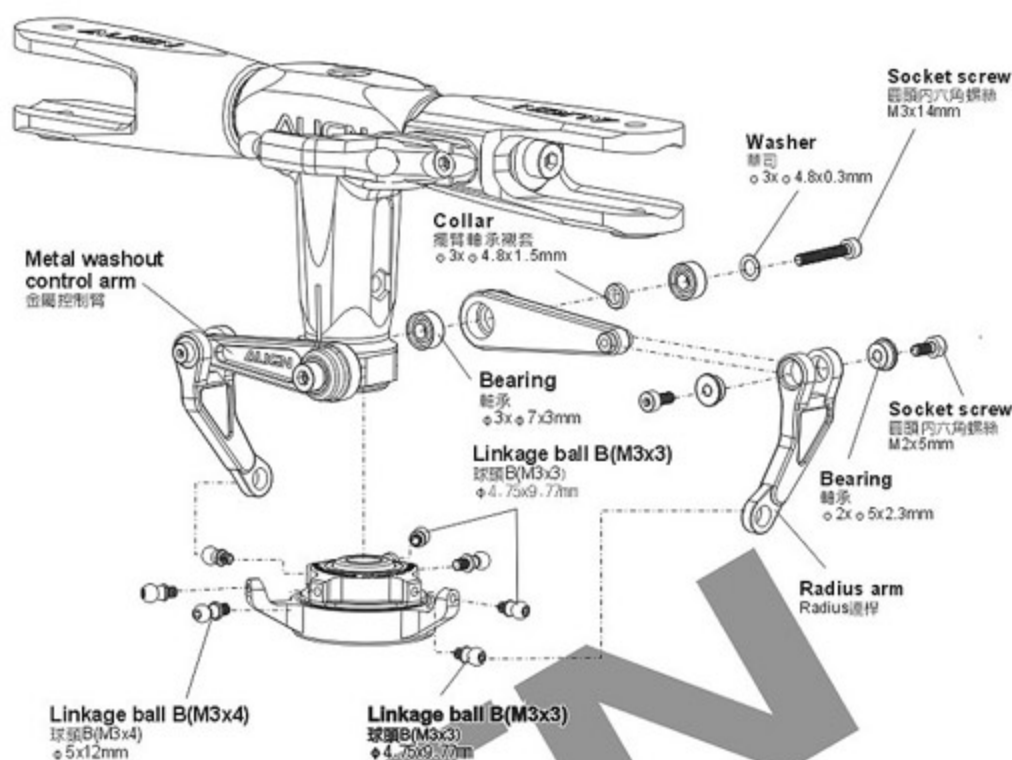

60FLH2



Linkage ball B(M3x4)
球頭B(M3x4)(φ5x12mm) x 2

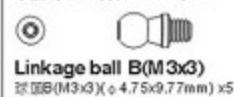

Linkage ball B(M3x3)
球頭B(M3x3)(φ4.75x9.7mm) x 5

60FLZ1

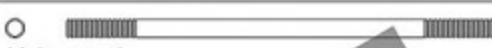

Linkage rod
連桿 φ2.5x56mm x 2



Ball Links x4
(use with link rod A)
連桿頭 x4 (連桿A專用)

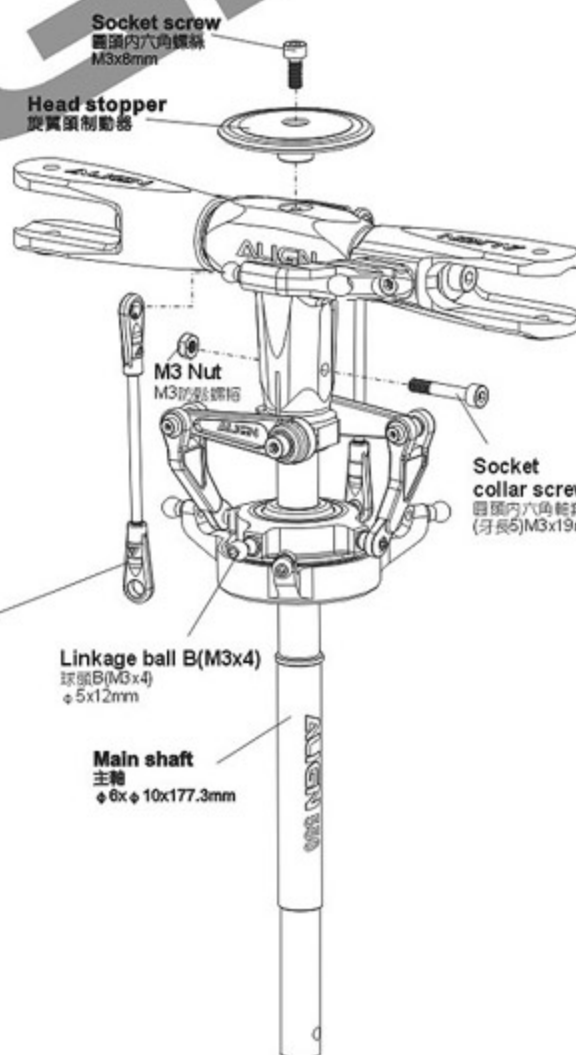

60FLH1A



Socket screw
圓頭內六角螺絲(M3x8mm) x 1

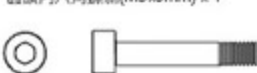

Socket collar screw
圓頭內六角軸套螺絲(牙長5)
(M3x19mm)



M3 Nut
M3 防鬆螺帽 x 1



CAUTION
注意

Already assembled by Factory. Before flying, please check if the screws are fixed with glue.

原裝組裝完成品，每一次飛行前請先確認螺絲是否已上膠不會鬆動。

Apply a little amount of T43 thread lock when fixing a metal part.
螺絲鎖附於金屬件請使用適量T43(螺絲膠)

60HB3A

Installation to middle hole position.
請鎖附中間孔位

Frame mounting block
機身固定塊

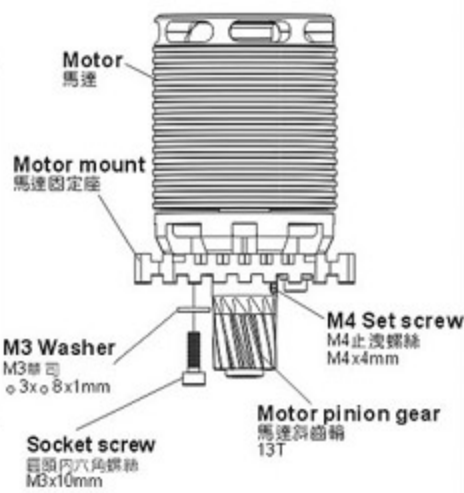
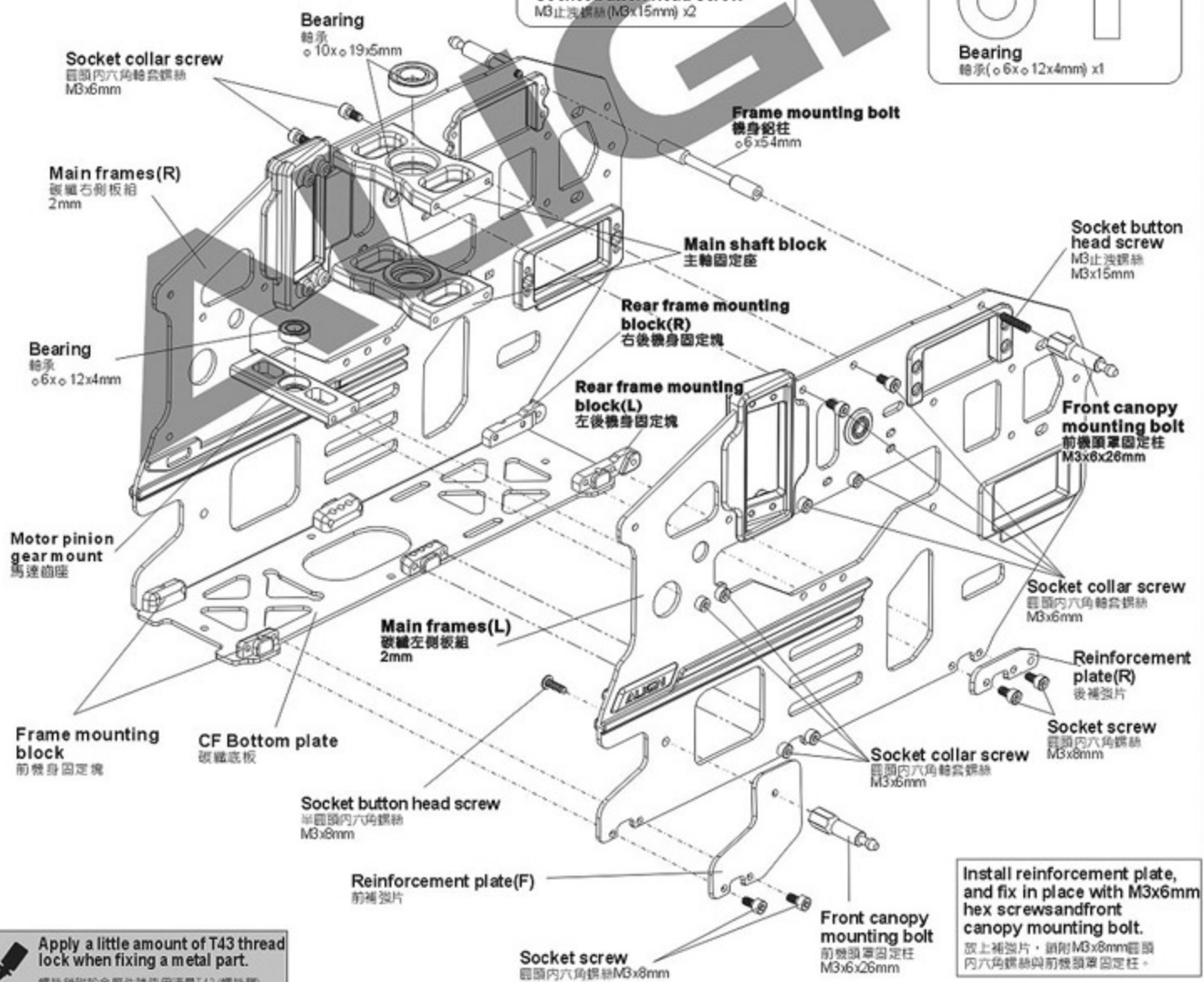
**60HM1****60HB3A****60HB4A****60HB3**

Install reinforcement plate, and fix in place with M3x6mm hex screws and front canopy mounting bolt.
裝上補強片，鎖附M3x8mm圓頭內六角螺絲與前機頂罩固定柱。

Apply a little amount of T43 thread lock when fixing a metal part.
螺絲鎖附於金屬件時使用適量T43(螺絲膠)

Main frame assembly key point :

First do not fully tighten the screws of main frames and put two bearings through the main shaft to check if the movements are smooth. The bottom bracket must be firmly touched the level table top(glass surface) : please keep the smooth movements on main shaft and level bottom bracket, then slowly tighten the screws. This assembly can help for the power and flight performance.

機身側板組立重點：

側板螺絲先不完全鎖緊，放入主軸貫穿二顆軸承確認上下移動必需滑順，主體底板必須與水平桌面（玻璃平面）踏實緊貼：請保持主軸滑順與底板平行桌面後慢慢鎖緊螺絲。正確側板的組裝對動力與飛行性能有顯著幫助。

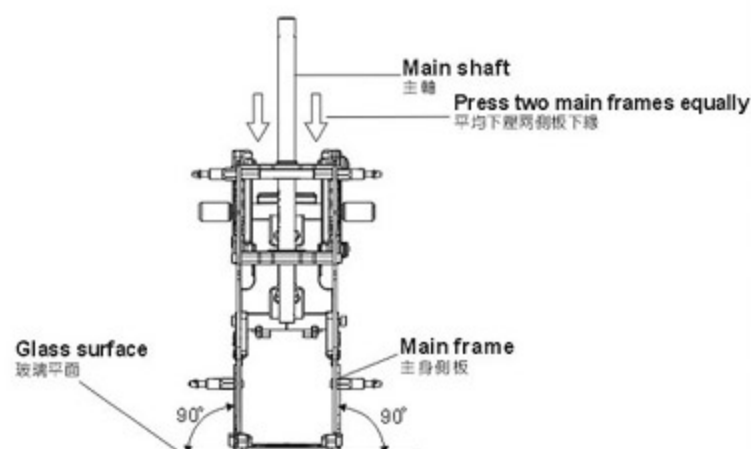

600NG1

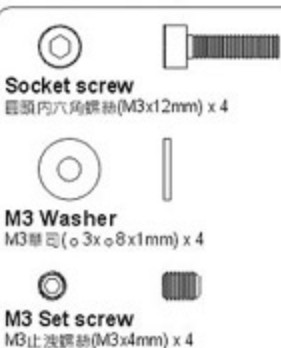

60HB4



60HB4A



60HB3A

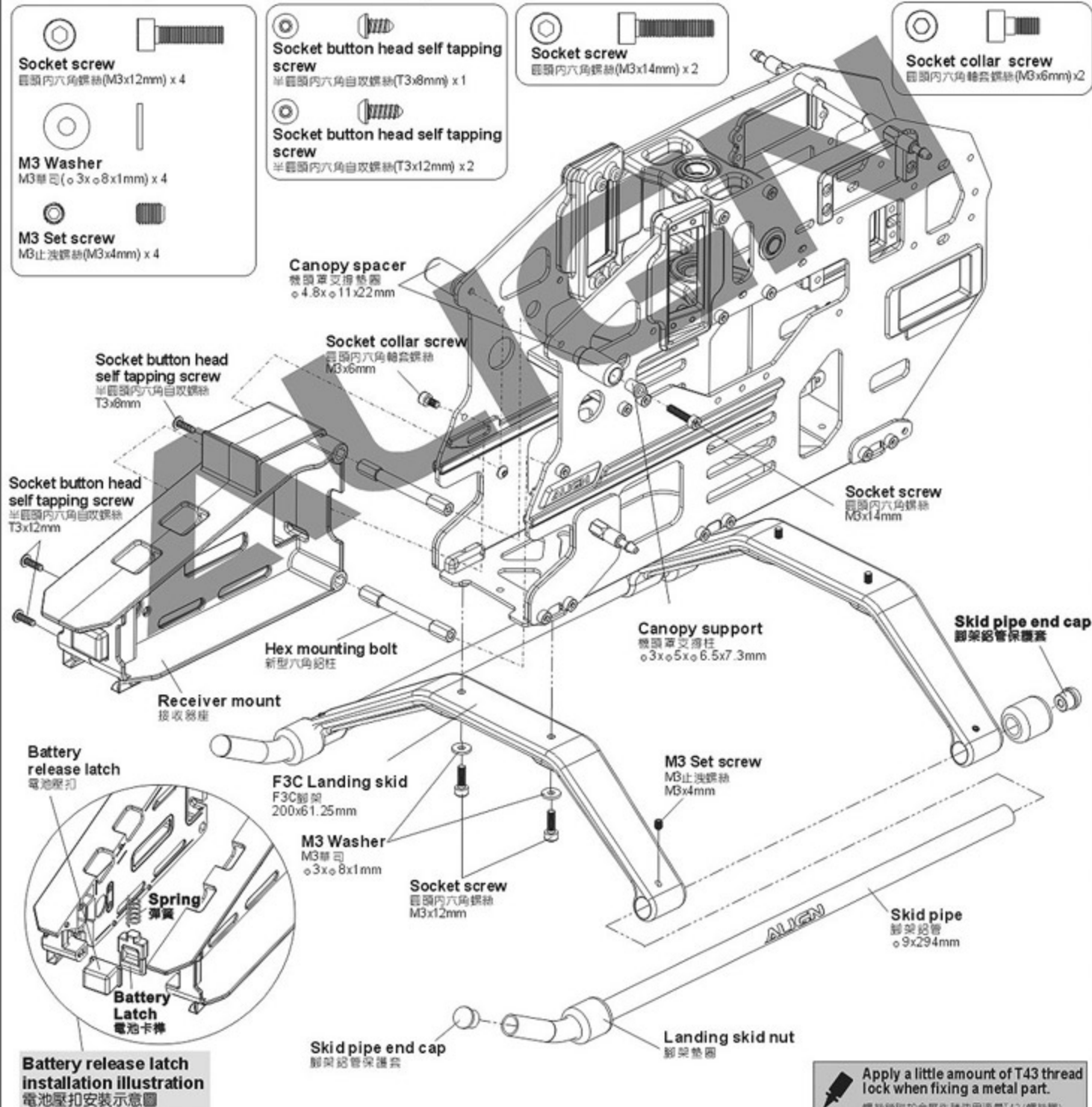

Battery release latch
installation illustration
電池壓扣安裝示意圖

Apply a little amount of T43 thread lock when fixing a metal part.
螺絲鎖附於金屬件請使用適量T43(螺絲膠)



注意

Option equipment

另購品

HSP61013T is suitable for Align and Futaba servos.

HSP61014T is suitable for JR servos.

HSP61013T 適用於亞拓、Futaba系列伺服器

HSP61014T 適用於JR系列伺服器

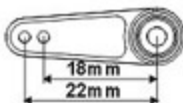

If servo of other brands are used, install the linkage ball 22mm from the center of servo horn.

若使用他牌伺服器時，請將球頭鎖附於距離伺服器出力軸心22mm的孔位。



Apply a little amount of T43 thread lock when fixing a metal part.

螺絲鎖附於金屬件請使用適量T43(螺絲膠)

Option equipment

另購品

DS610 Digital Servo :

1. 1520 μ s standard band / 1520 μ s 寬頻系統
2. Stall torque / 輸出扭力 : 9.6kg.cm(4.8V)
12.0kg.cm(6.0V)
3. Motion speed / 動作速度 : 0.10sec/60 (4.8V)
0.08sec/60 (6.0V)
4. Dimension / 尺寸 : 40.3 x 20.1 x 36mm
5. Weight / 重量 : 52.2g

DS610 Servo
DS610伺服器

Metal elevator servo mount
金屬升降伺服器座

Option equipment
另購品

Metal servo arm
金屬伺服器臂

Use the outer hole
請鎖附於外孔

Linkage ball A(M2x3.5)
球頭A(M2x3.5)
 ϕ 4.75x8.18mm

Screw
圓頭十字螺絲
M3x8mm

Rubber damper
避震橡膠

Servo plate
伺服器板片

Socket button head screw
半圓頭內六角螺絲
M2.5x12mm

Socket button head screw
半圓頭內六角螺絲
M2.5x12mm

Linkage ball A(M2x3.5)
球頭A(M2x3.5)
 ϕ 4.75x8.18mm

M2 Nut
M2螺帽

Screw
圓頭十字螺絲
M3x8mm

DS650 Servo
DS650伺服器

Servo plate
伺服器板片

Socket button head self tapping screw
半圓頭內六角自攻螺絲 T2.6x12mm

Servo arm
伺服器臂

Option equipment
另購品

DS650 Digital Servo :

1. 1520 μ s standard band / 1520 μ s 寬頻系統
2. Stall torque / 輸出扭力 : 4.0kg.cm(4.8V)
5.0kg.cm(6.0V)
3. Motion speed / 動作速度 : 0.058sec/60 (4.8V)
0.048sec/60 (6.0V)
4. Dimension / 尺寸 : 40.3 x 20.1 x 36mm
5. Weight / 重量 : 56g

60HZ3

Linkage ball A(M2x3.5)
球頭A(M2x3.5) (ϕ 4.75x8.18mm) x 2

Socket button head self tapping screw
半圓頭內六角自攻螺絲(T2.6x12mm) x 4

M2 Nut
M2螺帽 x 1

Socket button head screw
半圓頭內六角螺絲(M2.5x12mm) x 8

Recommend sanding the marked position as below illustration with a waterproof abrasive paper (#800-1000) to avoid the wires of electric parts to be cut.

建議於下圖色塊標示處，使用#800-1000水砂紙打磨，可防止電子設備電線被割破。

Waterproof abrasive paper
水砂紙

60HB3A



Socket collar screw
圓頭內六角輪套螺絲(M3x6mm) x 4

60HZ3



Short linkage ball A (M2X3)
短球頭A(M2X3) (φ4.75x13.5mm) x 2



Socket button head self tapping screw
半圓頭內六角自攻螺絲(T2.6x12mm) x 8



Option equipment

另購品

HSP61013T is suitable for Align and Futaba servos.
HSP61014T is suitable for JR servos.

HSP61013T 適用於亞拓、Futaba系列伺服器

HSP61014T 適用於JR系列伺服器

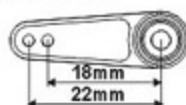

If servo of other brands are used, install the linkage ball 22mm from the center of servo horn.

若使用他牌伺服器時，請將球頭鎖附於距離伺服器出力輪心22mm的孔位。



Make sure the motor mount is fully fastened before fasten the motor pinion gear mount.

先將馬達固定座鎖緊固定後，再將馬達齒座鎖緊。

Option equipment

另購品

Metal servo arm
金屬伺服臂

Linkage ball A
球頭A (M2x3)
(φ4.75x13.5mm)

Screw
圓頭十字螺絲
M3x8mm

Socket button head self tapping screw
半圓頭內六角自攻螺絲
T2.6x12mm

Servo plate
伺服器板片

DS610 Servo
DS610伺服器

Motor
馬達

Please make sure there is no interference when you install linkage ball.

安裝球頭時須確認動作無干涉。

Use the outer hole
請鎖附於外孔

Linkage ball A
球頭A (M2X3)
φ4.75x13.5mm

60HZ3

Screw
圓頭十字螺絲
M3x8mm

Metal servo arm
金屬伺服臂

Option equipment
另購品

Socket collar screw
圓頭內六角輪套螺絲M3x6mm

DS610 Servo
DS610伺服器

Option equipment

另購品

DS610 Digital Servo :

1. 1520 μs standard band / 1520 μs 寬頻系統

2. Stall torque / 輸出扭力 : 9.6kg.cm (4.8V)

12.0kg.cm (6.0V)

3. Motion speed / 動作速度 : 0.10sec/60 (4.8V)

0.08sec/60 (6.0V)

4. Dimension / 尺寸 : 40.3 x 20.1 x 36mm

5. Weight / 重量 : 52.2g

Apply a little amount of T43 thread lock when fixing a metal part.

螺絲鎖附於金屬件請使用適量T43(螺絲膠)

60HB3

Socket button head screw
半圓頭內六角螺絲(M3x6mm) x 4

Bearing
軸承(φ3xφ7x3mm) x 2

M4 Set screw
M4止洩螺絲(M4x4mm) x 1

Collar
升降運動控制臂套
(φ3xφ4x1.5mm) x 2

Control shaft collar
運動桿套圈(φ5xφ6.3x14.5mm) x 1

60HB3A

Linkage ball B
球頭B(M3x3) (φ4.75x9.77mm) x 1

Socket screw
圓頭內六角螺絲(M2.5x8mm) x 1

Elevator ball link
升降臂連接頭 x 1

Washer
華司(φ5xφ7x0.2mm) x 2

Washer
華司(φ5xφ7x0.5mm) x 2

Washer
華司(φ3xφ5.5x0.3mm) x 2

60FLZ1

Linkage rod(D)
連桿(D) φ1.96x32mm x 1

Ball link
600連桿頭 x 2

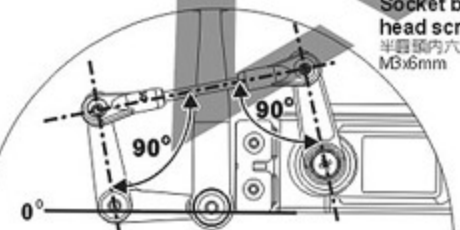
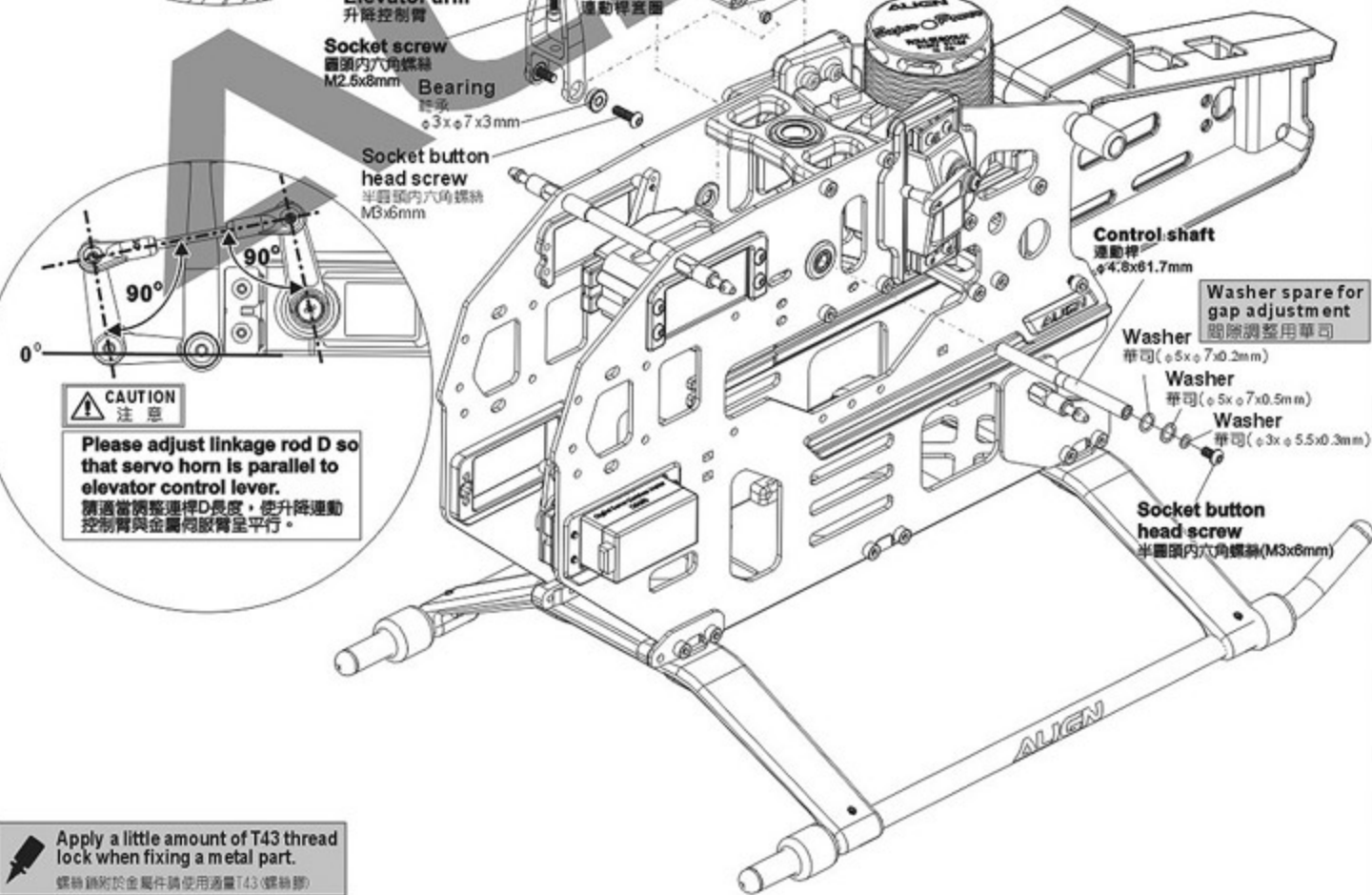
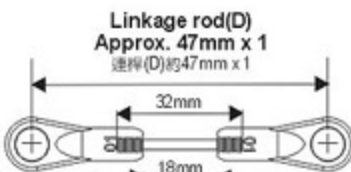

Apply a little amount of T43 thread lock when fixing a metal part.
螺絲鎖於金屬件請使用適量T43(螺絲膠)

60HT1

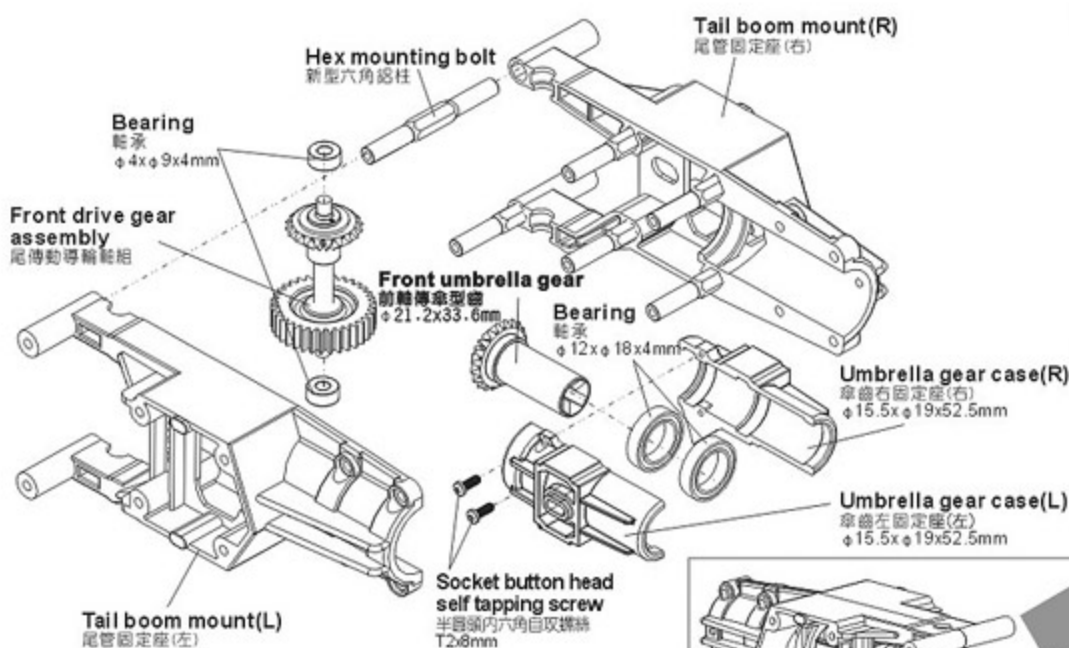

60HT2

Apply a little amount of T43 thread lock when fixing a metal part.
螺絲鎖附於金屬件請使用適量T43(螺絲膠)

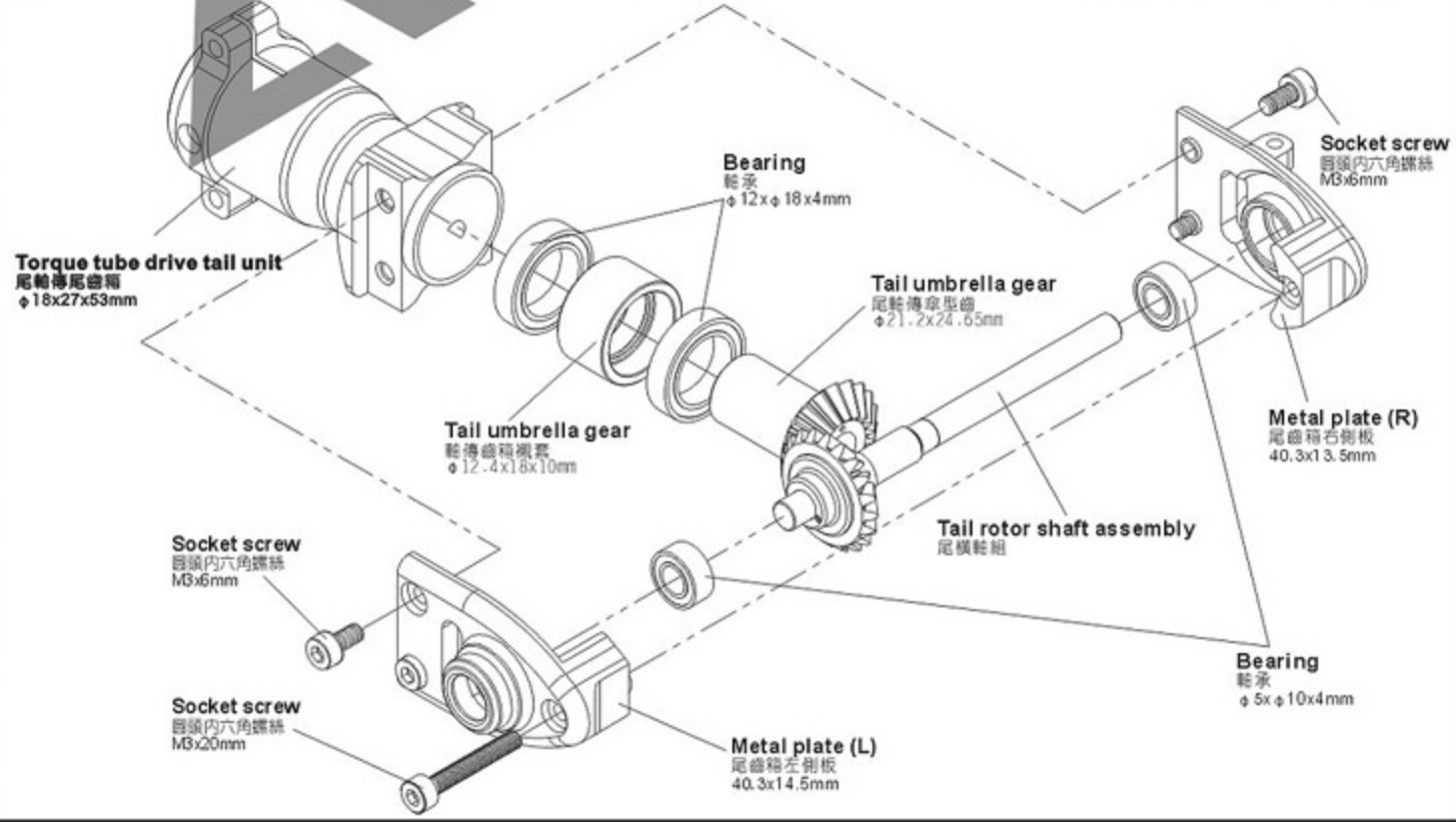

60HT2

Apply a little amount of T43 thread lock when fixing a metal part.
螺絲鎖附於金屬件請使用適量T43(螺絲膠)

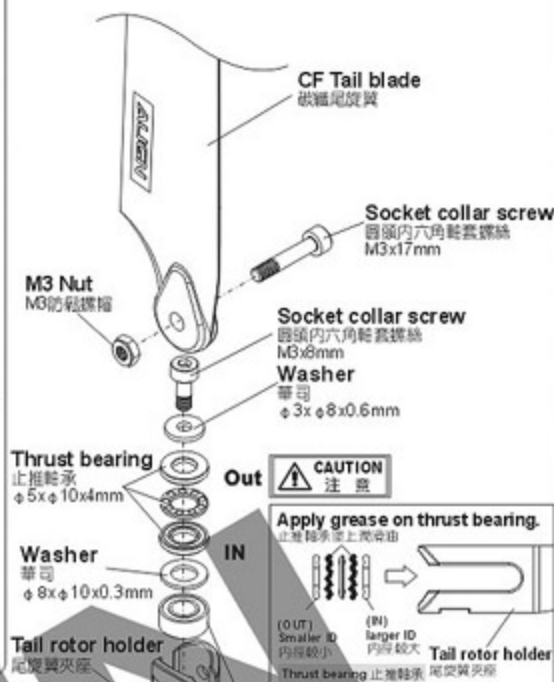
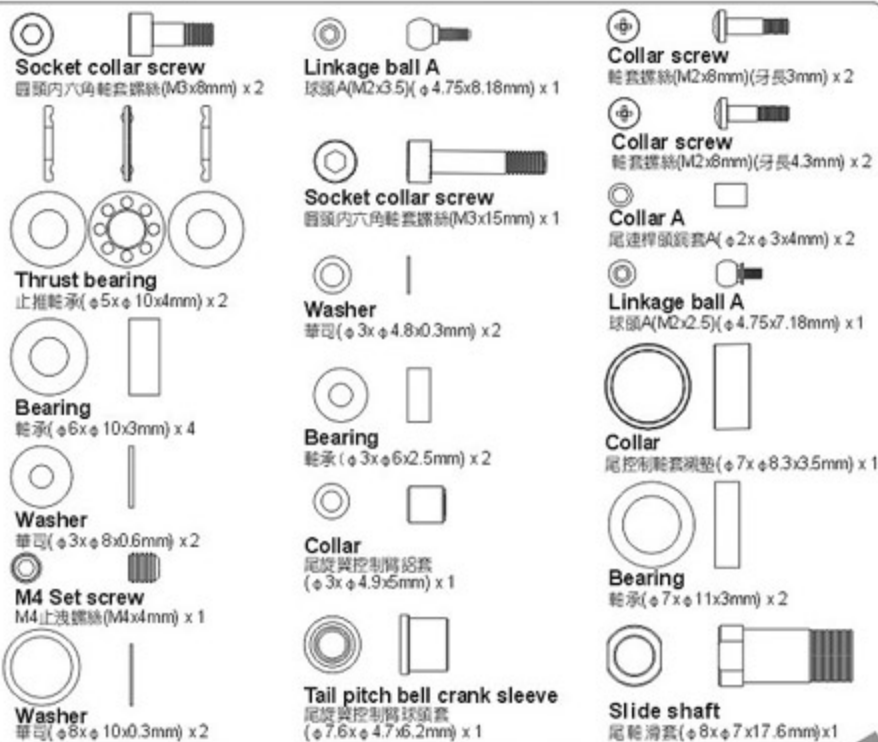

Please tighten M2x8mm collar screw firmly but not over tightened. Over tighten the screw will cause the installation of tail rotor shaft unsmoothly.
鎖附M2x8mm軸套螺絲請使用適量力道，過度鎖緊會造成尾旋翼軸組入不順。

CAUTION
注意

While assembly the slide shaft, please use suitable amount of T43 on the thread. Please do not use R48 anaerobics retainer or other high strength glue to avoid damages while maintenance or repairs.
組立尾輪滑套時，請使用適量的T43螺絲膠在螺絲上，嚴禁使用R48高膠合性軸承膠防止膠合過緊，以避免日後拆修維護零件之損傷。

Aim tail rotor hub at the concave of tail rotor shaft and fix it, please apply a little glue on the set screw.
尾旋翼T型座對準尾旋翼的凹位並鎖上，請確認止洩螺絲上膠。

Assembling Umbrella Gear: Please note to push the gear to the end at a fixed position, to make sure the gears mesh with each other smoothly.
傘齒組裝：注意務必前推到固定位，以避免齒咬合不順。

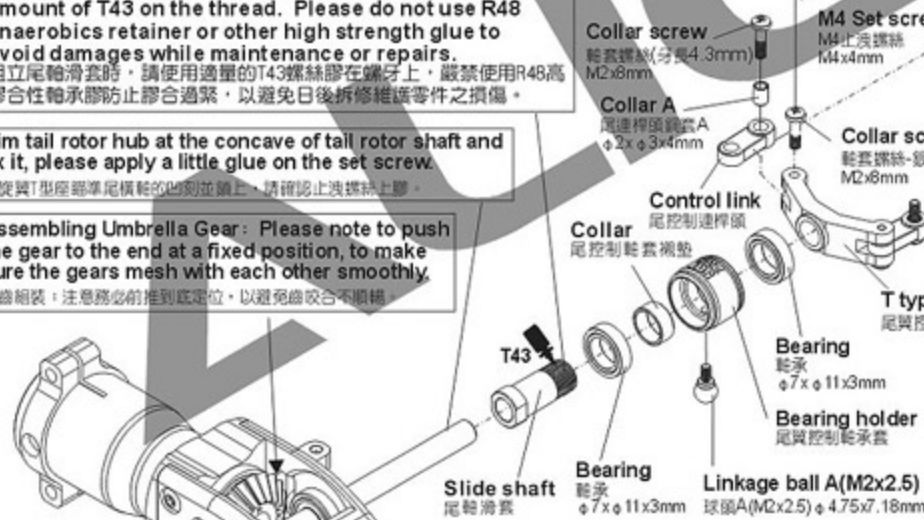

60HT2A

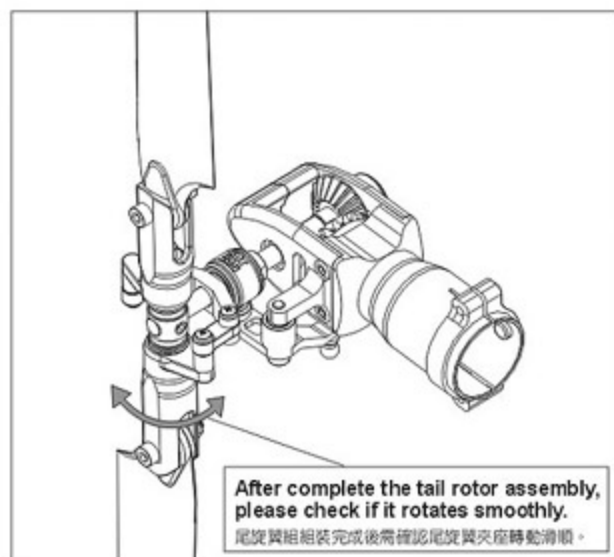

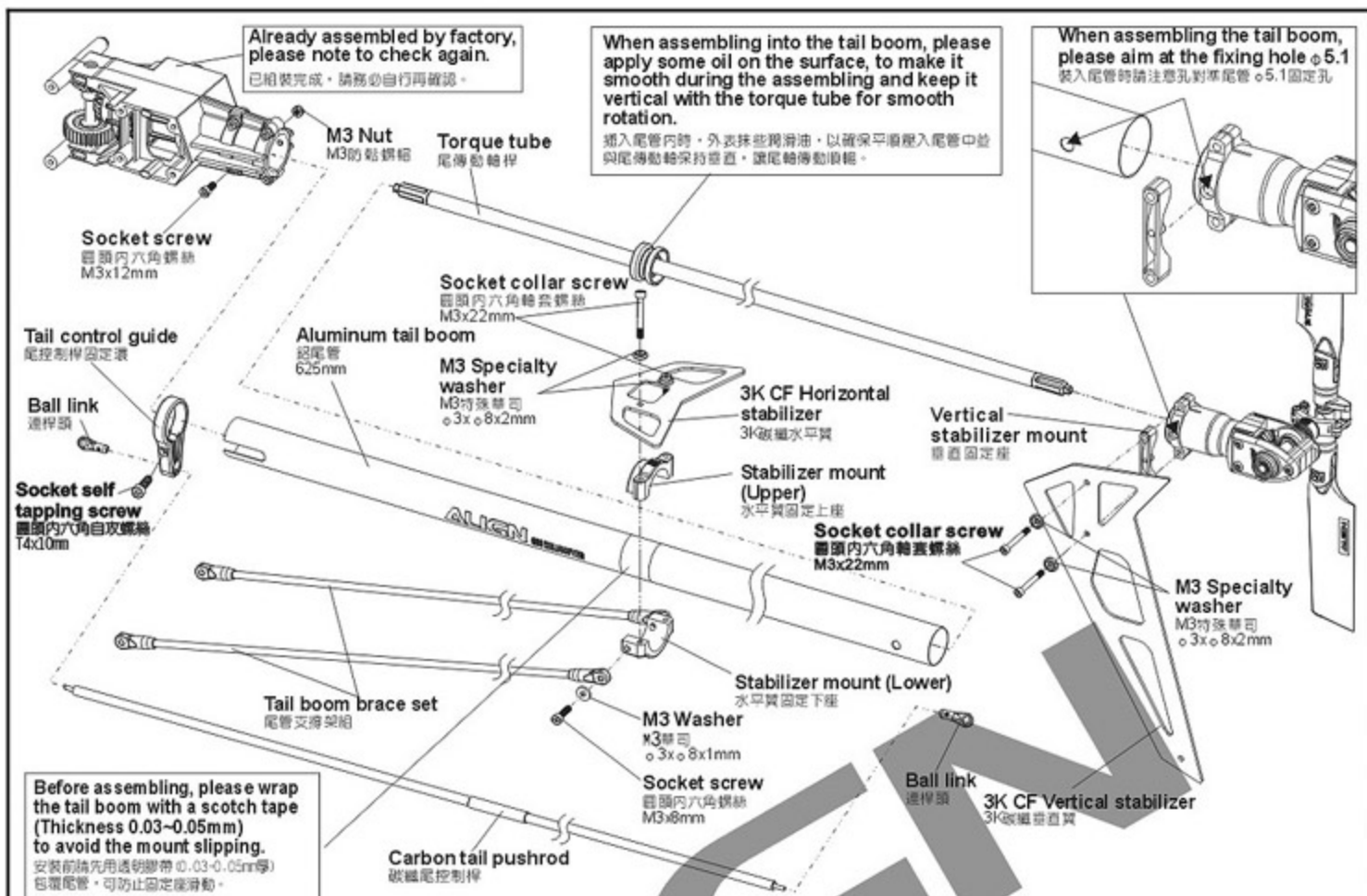

60HT4A



Tip to fix the torque tube 傳動軸軸承固定位置要領

Please apply some CA glue to fix bearing on the torque tube, avoid CA glue from the dust or may cause the bearing stuck. When assembling into the tail boom, please apply some oil and use the attached torque tube mount helper to press the bearing holder of the torque tube into the tail boom horizontally.

請以少量CA將軸承固定於尾傳動軸上，避免CA沾到軸承的助導蓋而導致軸承卡死，插入尾管內時，尾傳動軸軸承器外表抹些潤滑油，利用隨附軸承安裝套將尾傳動軸軸承器平行壓入尾管中不可歪斜。

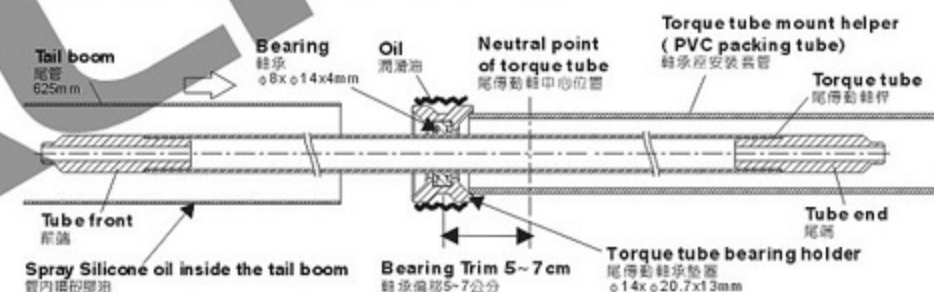

60HT5A



60HT5



60HT2



60HT1A



Skewed Torque tube bearing holder will interfere with torque tube rotation and cause unusual vibration.

尾傳動軸承座安裝歪斜會造成傳動軸運轉不順及尾部異常震動等問題

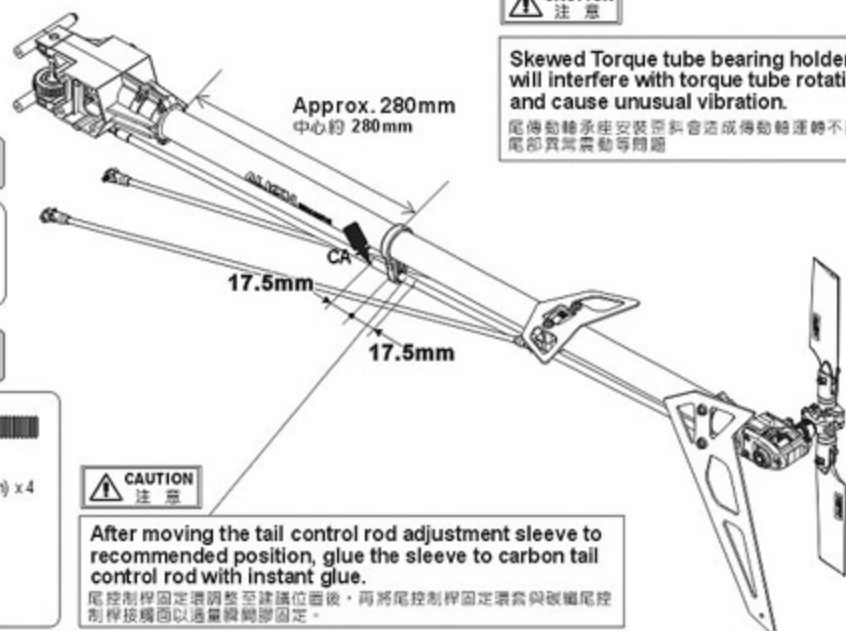

Apply a little amount of T43 thread lock when fixing a metal part.
螺絲鎖附於金屬件請使用適量T43(螺絲膠)

When tightening the main blade fixing screw, please tighten it firmly, but not over tighten, or it may cause the damage of main blade holder and result in danger.
鎖緊主旋翼螺絲須注意適當緊度即可，過緊可能導致主旋翼夾座受損，飛行意外發生。

Socket collar screw
圓頭內六角軸套螺絲
M4x25mm

600 3G Carbon fiber blade
600 3G碳纖維主旋翼

M4 Nut
M4防鬆螺帽

60HB5

Main Blade Fixing Screw
鎖主旋翼用螺絲



Socket collar screw
圓頭內六角軸套螺絲(M4x25mm) x 2



M4 Nut
M4防鬆螺帽 x 2

60FLH1A

Socket collar screw

圓頭內六角軸套螺絲(M3x20mm) x 1



M3 Nut
M3防鬆螺帽 x 1

60FLH2

Main shaft spacer(0.5)
主軸墊片(0.5)
($\phi 12 \times \phi 16 \times 0.5 \text{mm}$) x 1

Spare part:
Main shaft spacer(0.3)
備品：主軸墊片(0.3)
($\phi 10.1 \times \phi 14 \times 0.3 \text{mm}$) x 1

Standard Equipment :
Main shaft spacer(1)

標準品：主軸墊片(0.5)
($\phi 12 \times \phi 16 \times 0.5 \text{mm}$)

Spare part : Main shaft spacer(0.3)
備品：主軸墊片(0.3) $\phi 10.1 \times \phi 14 \times 0.3 \text{mm}$

Linkage rod(D)
Approx. .48mm x 2
連桿(D)約.48mm x 2

32mm

15mm

CNC Main drive gear set
CNC主齒輪組

Socket screw
圓頭內六角軸套螺絲
M3x20mm

M3 Nut
M3防鬆螺帽

60FLZ1

Linkage rod(D)
連桿(D)($\phi 1.96 \times 32 \text{mm}$) x 2



Ball link
連桿頭 x 4

Before fastening the M4 set screw, make sure the motor pinion gear is contacted with the bearing in the motor gear case downward.
馬達主齒向下頂到馬達齒座輪承後，再將M4止洩螺絲鎖緊。

Battery installation illustration 電池安裝示意圖



Please fix the 2 batteries on the battery mount evenly.
2顆電池請平均固定於電池板上。

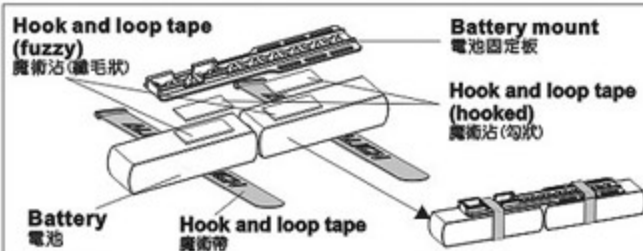

Press this latch to allow the battery to slide out along the rail.
電池抽出前請先將電池壓扣在內壓，順著滑軌抽出

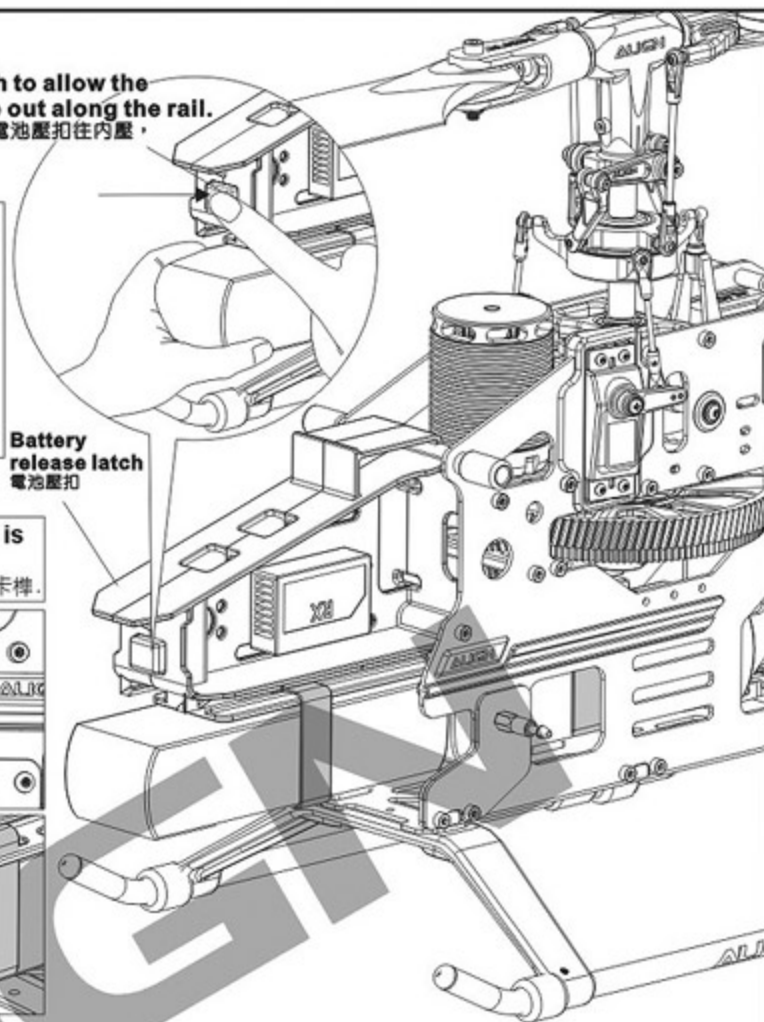

Slide the battery mounting plate along the rail until a "click" is heard to make sure the battery mounting plate is latched.
將電池固定板順著電池滑軌裝入，至發出「喀答」聲響，使電池固定板卡入卡槽。

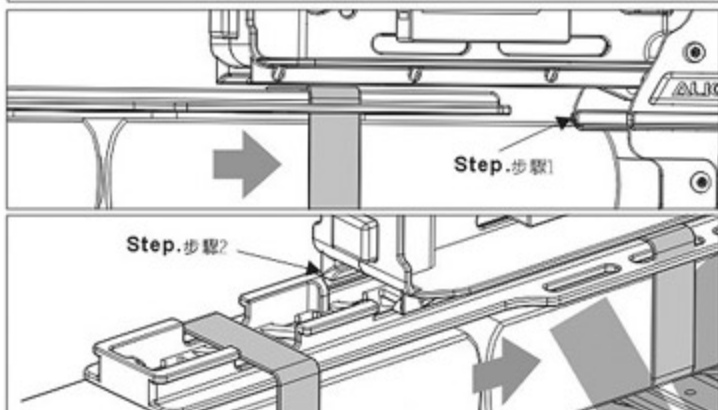

8. EQUIPMENT INSTALLATION 各項設備配置圖



1. Consult the following diagram for 3GX installation direction, with arrow pointing toward nose or tail of helicopter. 3GX needs to be mounted flat on gyro mounting platform, away from vibration sources.
2. Two pieces of foam mounting tape can be used if helicopter experiences vibration induced flight instability. However, if this still doesn't cure the problem, please check the helicopter mechanics and minimize mechanical vibrations, or reduce the headspeed.
3. Please secure with genuine factory issued double sided anti-vibration mounting tape.

※If 3GX was to be mounted inverted, please enter connect anti-torque compensation section and set it as "reverse" (STATUS LED turns red); Or connect the 3GX computer link and enter rudder parameters, set the left directional setting for anti-torque compensation to reverse to avoid the effect of the performance of gyro lock.

1. 3GX擺放方向請參照圖示，方向指示箭頭指向機頭或機尾，水平擺放於陀螺儀固定座，並避開震動源。
 2. 機體震動會影響陀螺儀偵測，造成飛行不穩定，可於3GX下方黏附2片泡棉減震，若仍未改善，請檢查機體排除震動或降低主旋翼轉速。
 3. 請使用原廠提供避震泡棉雙面膠固定。
- ※ 選擇3GX面板翻下的安裝方式時，請進入設定選項中的反扭力補償設定，並將反扭力補償設為「反向」(STATUS燈為紅燈)，或連線至3GX電腦介面，進入尾舵參數，將「反扭力補償」左側的開關設定為反向，以免影響陀螺儀鎖定效果。

Rev. Anti-torque compensation

反向 反扭力補償



Option equipment 另購品

3GX Flybarless System 3GX 無平衡翼系統



Directional Arrow 方向指示

Option equipment 另購品

Remote receiver 衛星天線

Battery of receiver 接收器電池

Receiver mount 接收器座

3GX foam tape 3GX 泡棉

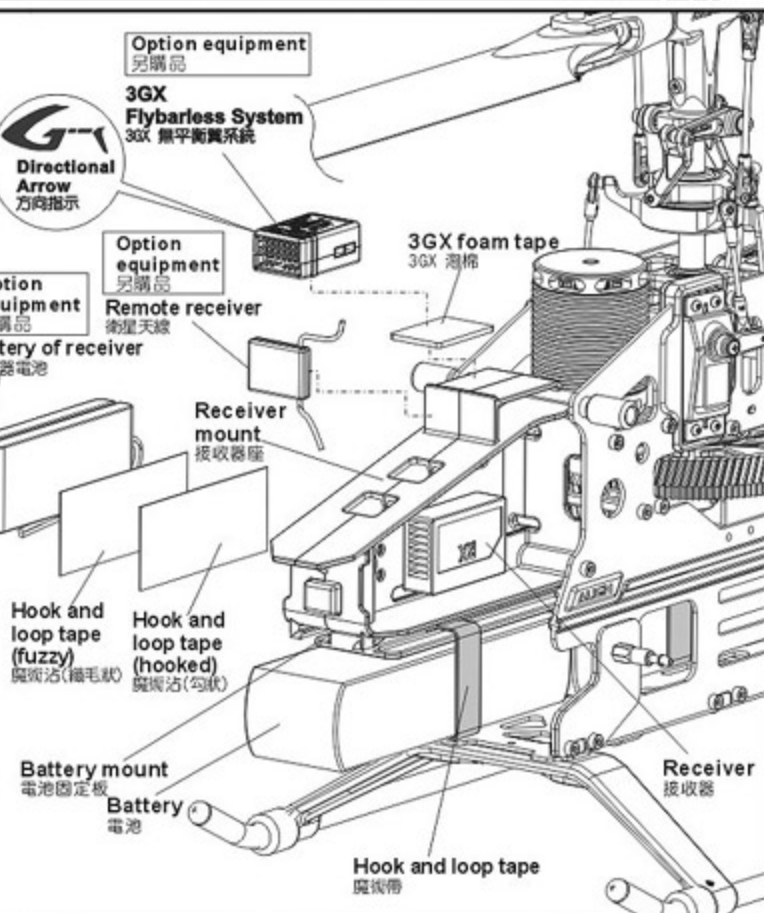

Hook and loop tape (fuzzy) 魔術沾(繡毛狀)

Hook and loop tape (hooked) 魔術沾(勾狀)

Battery mount 電池固定板

Battery 電池

Receiver 接收器

Hook and loop tape 魔術帶

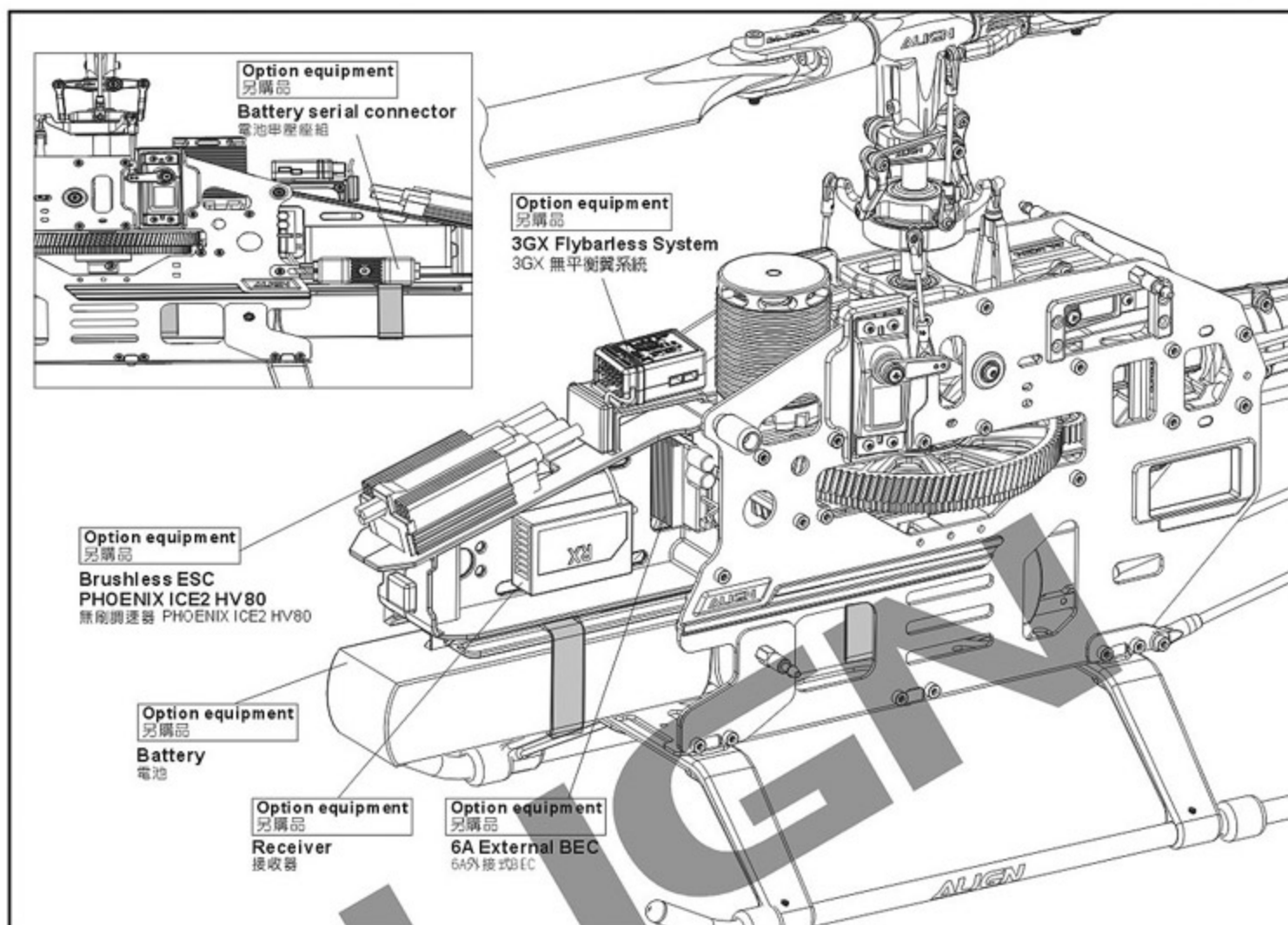

10. CANOPY ASSEMBLY 機頭罩安裝

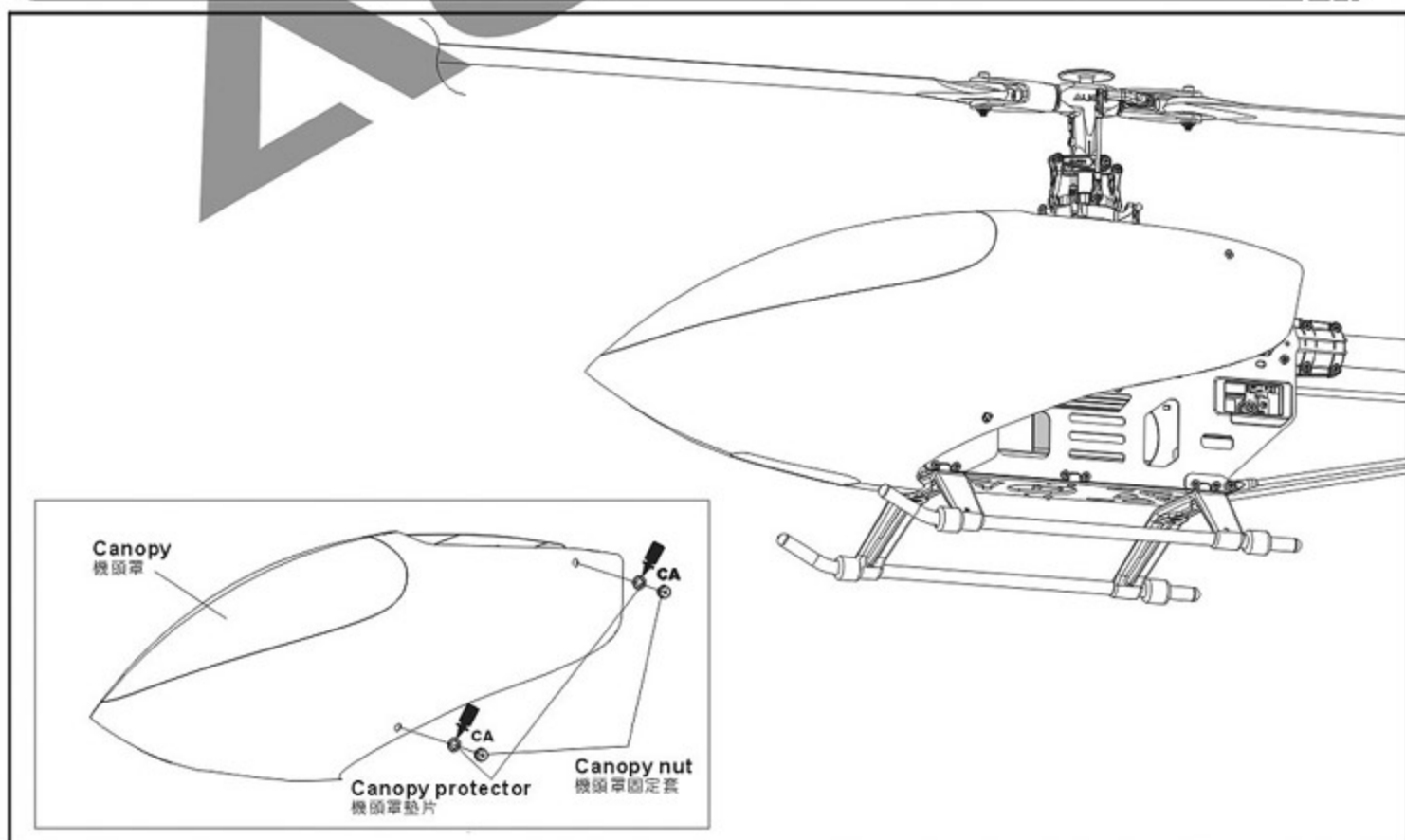

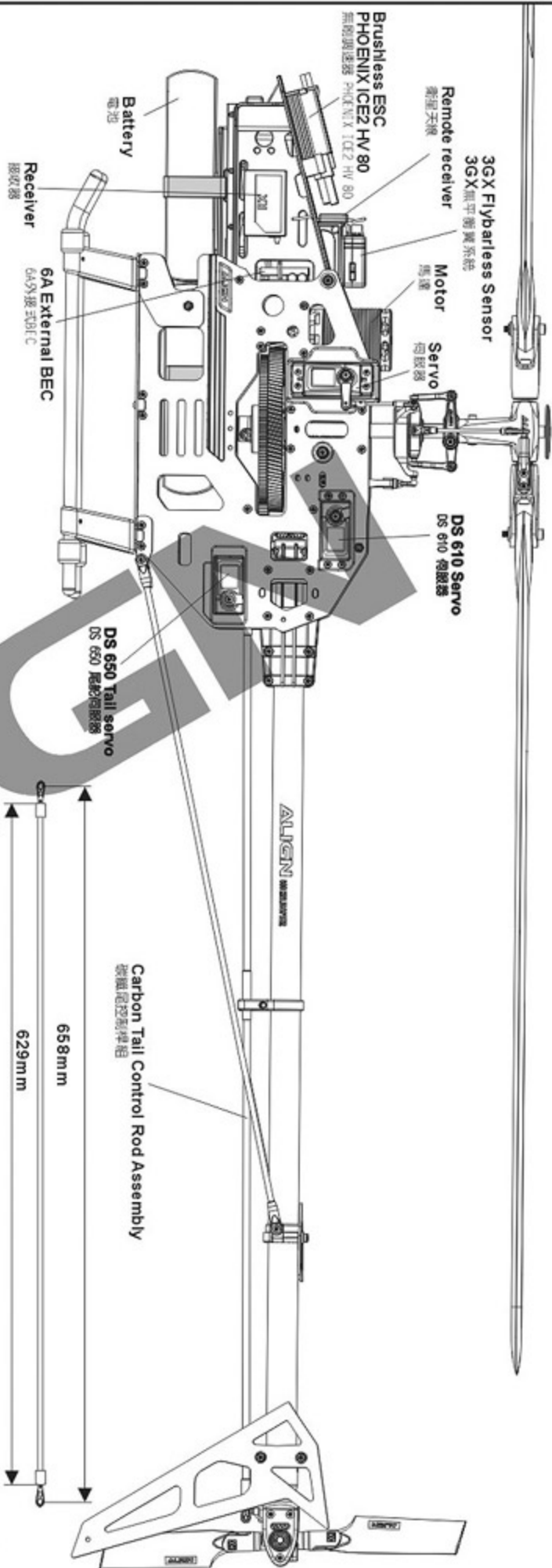

Option equipment
3GX FLYBARLESS SYSTEM 3GX無平衡翼系統組
PARTS IDENTIFICATION 各部位名稱

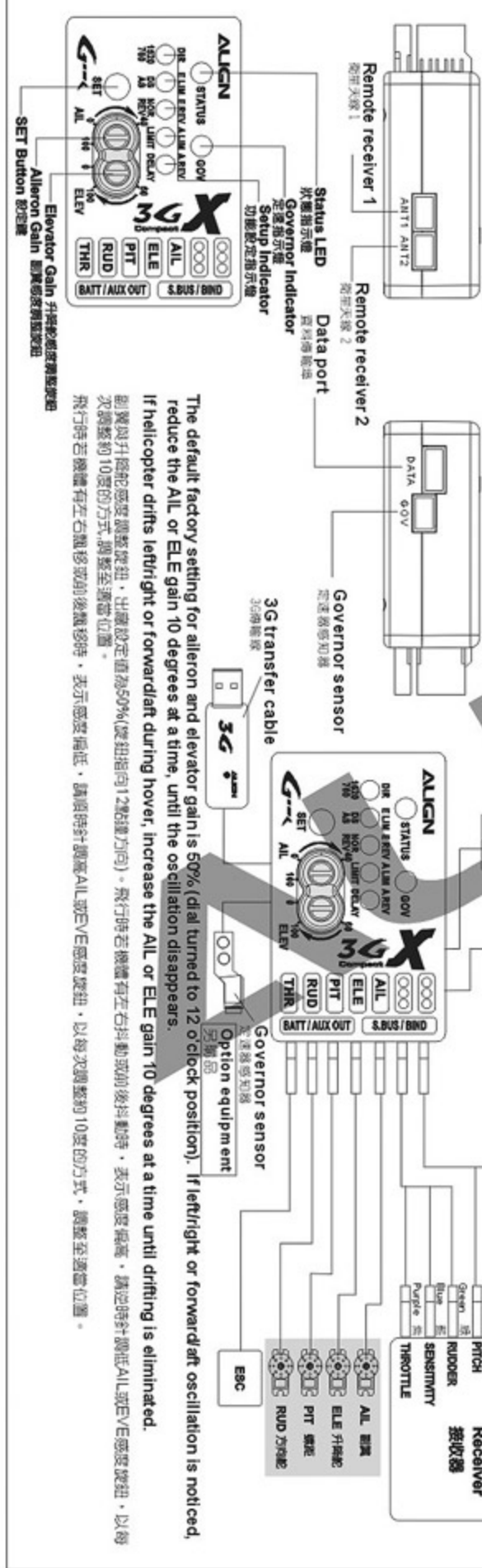

The default factory setting for aileron and elevator gain is 50% (dial turned to 12 o'clock position). If left/right or forward/aft oscillation is noticed, reduce the AIL or ELE gain 10 degrees at a time, until the oscillation disappears.

If helicopter drifts left/right or forward/aft during hover, increase the AIL or ELE gain 10 degrees at a time until drifting is eliminated. Adjust the AIL or ELE gain 10 degrees at a time, until the oscillation disappears.

調整與升降舵密度調整旋鈕，出廠設定值為50% (旋鈕指向12點鐘方向)。飛行時若機體有左右抖動或前後抖動時，表示密度偏低，請逆時針調低AIL或ELEV密度旋鈕，以每次調整約10度的方式，調整至適當位置。

飛行時若機體有左右飄移或前後飄移時，表示密度偏低，請順時針調高AIL或ELEV密度旋鈕，以每次調整約10度的方式，調整至適當位置。

To set this option is to turn on the transmitter and connect to BEC power.
此項設定只要開啓發射器，接上BEC電源即可進行操作。

JR Transmitter/Servo JR遙控器對應伺服器關係

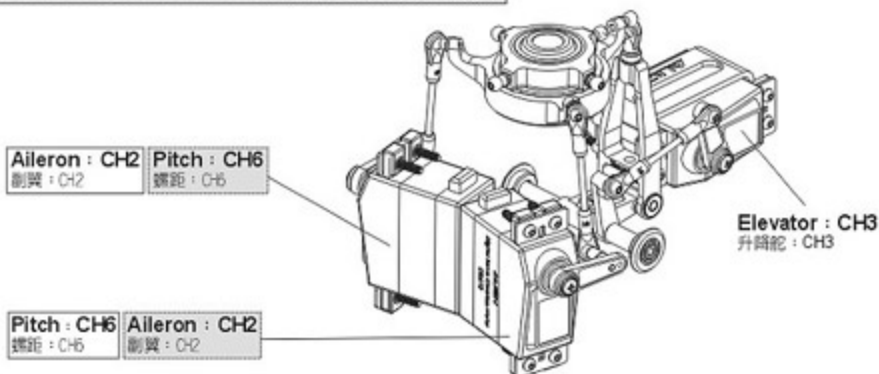

Positions of CH2 · CH6 are exchangeable, After assembling as photo (Note: Set the transmitter under CCPM 120 degrees mode), pull throttle stick (pitch) upward. If one swashplate servo (or two servos) moves downward, adjust reverse switch (REV) on the transmitter to make it moves upward. If three servo move downward, adjust the travel value (+) of SWASH CH6 on the transmitter to make them move upward. When the actions of Aileron and Elevator are opposite, adjust travel values of SWASH CH2 and Ch3.

CH2 · CH6可互換配置，依圖連結後(注意：遙控器須設定於CCPM 120°十字盤模式)，將油門搖桿(Pitch)往上推，若十字盤伺服器有1個或2個往下移時，請調整遙控器的反轉開關(REV)使伺服器往上，若3個伺服器同時往下移時，請調整遙控器 SWASH CH6 行程量的正負值，使伺服器同時往上平移，副翼與前後動作相反時，同樣調整 SWASH CH2 · CH3 行程量正負值。

FUTABA/HITEC Transmitter/Servo FUTABA/HITEC遙控器對應伺服器關係

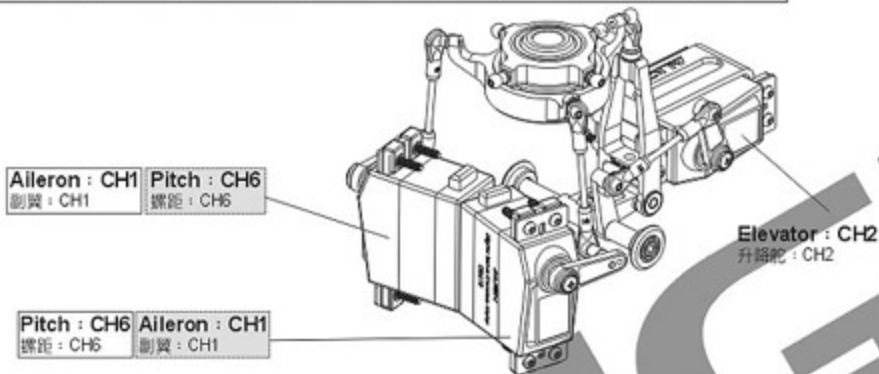

Positions of CH1 · CH6 are exchangeable, After assembling as photo (Note: Set the transmitter under CCPM 120 degrees mode), pull throttle stick (pitch) upward. If one swashplate servo (or two servos) moves downward, adjust reverse switch (REV) on the transmitter to make it moves upward. If three servo move downward, adjust the travel value (+) of SWASH CH6 on the transmitter to make them move upward. When the actions of Aileron and Elevator are opposite, adjust travel values of SWASH CH1 and Ch2.

CH1 · CH6可互換配置，依圖連結後(注意：遙控器須設定於CCPM 120°十字盤模式)，將油門搖桿(Pitch)往上推，若十字盤伺服器有1個或2個往下移時，請調整遙控器的反轉開關(REV)使伺服器往上，若3個伺服器同時往下移時，請調整遙控器 SWASH CH6 行程量的正負值，使伺服器同時往上平移，副翼與前後動作相反時，同樣調整 SWASH CH1 · CH2 行程量正負值。

13.ADJUSTMENTS FOR GYRO AND TAIL NEUTRAL SETTING 陀螺儀與尾翼中立點設定調整

Turn off Revolution mixing(RVMX) mode on the transmitter, then set the gain switch on the transmitter and the gyro to Head lock mode. The gain setting is about 70%, and after transmitter setting, connect to BEC power to work on tail neutral setting.

Note: When turn on BEC power, please do not touch tail rudder stick and the helicopter. Then wait for 3 seconds, make tail servo arm and tail servo at a right angle(90 degrees), tail pitch assembly must be correctly fixed about in the middle of the travel of tail rotor shaft for standard neutral setting.

發射器內陀螺儀設定請關閉根軸混控模式，並將發射器上的感度開關與陀螺儀切至鎖定模式，感度設約 70% 左右，發射器設定完成後接上BEC接收電源，即可進行尾中立點設定。

注意：當啓動BEC電源時請勿撥動尾舵搖桿或碰觸機體，待3秒陀螺儀鎖定後尾伺服臂需與尾伺服器約成 90°，尾旋翼控制組須正確置於尾橫軸行程約中間位置，即為標準尾中立點設定。

TAIL NEUTRAL SETTING 尾中立點設定

After setting Head Lock mode, correct setting position of tail servo and tail pitch assembly is as photo. If the tail pitch assembly is not at the neutral position, please adjust the length of rudder control rod to trim.

陀螺儀鎖定後尾伺服器與尾 Pitch控制組正確置於位置。若尾 Pitch控制組未置中時請調整尾控制連桿的長度來修正。

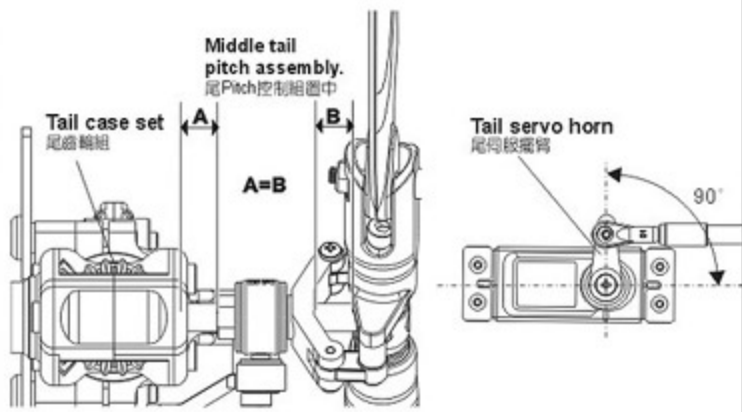

HEAD LOCK DIRECTION SETTING OF GYRO 陀螺儀鎖定方向設定

To check the head lock direction of gyro is to move the tail counterclockwise and the tail servo horn will be trimmed clockwise. If it trims in the reverse direction, please switch the gyro to "REVERSE".

陀螺儀鎖定方向確認，當手搖尾部逆時鐘擺動，尾伺服器臂應逆時鐘修正，反向時請切換陀螺儀上“鎖定反向”開關修正。



GENERAL FLIGHT 一般飛行模式



Stick position at high/Throttle 100%/Pitch+12°
搖桿高速/油門100%/Pitch-12°

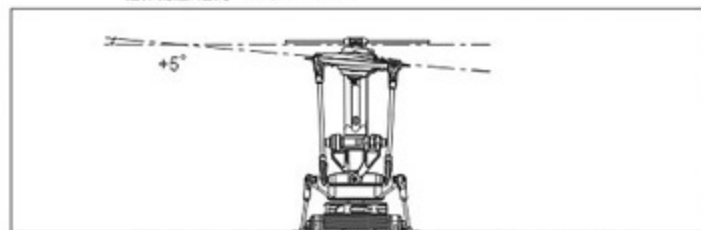

Stick position at Hovering/Throttle 60%~65%/Pitch+5°
搖桿停懸/油門60%~65%/Pitch-5°



Stick position at low/Throttle 0%/Pitch0~-2°
搖桿低速/油門0%/Pitch0~-2°

GENERAL FLIGHT
一般飛行模式

	Throttle 油門	Pitch 螺距
5	100% High speed 100% 高速	+12°
4	80%	
3	60%~65% Hovering 60%~65% 停懸	+5°
2	40%	
1	0% Low speed 0% 低速	0°~-2°

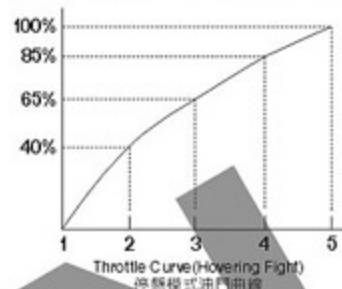

Pitch and Rotation Speed Pitch與轉速關係

TIP: It is recommended to use a lower pitch setting when using higher RPM/Head speed. This will allow for better power.

搭配要領: 如果使用較高轉速馬達動力建議搭配調低 Pitch, 將獲得較佳動力效能。

3D FLIGHT 3D特技飛行模式



Stick position at high/Throttle 100%/Pitch+12°
搖桿高速/油門100%/Pitch-12°

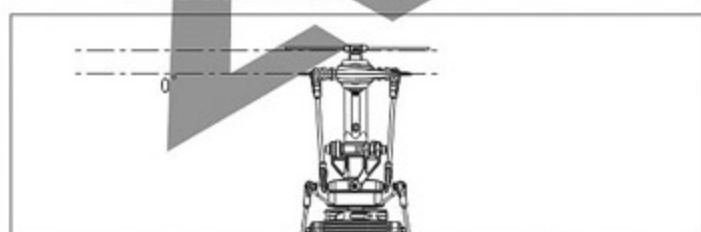

Stick position at middle/Throttle 85%/Pitch 0°
搖桿中速/油門85%/Pitch 0°

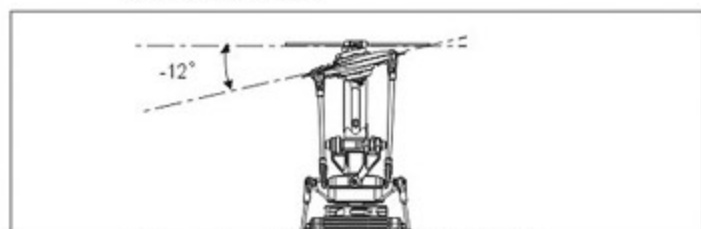

Stick position at low/Throttle 100%/Pitch-12°
搖桿低速/油門100%/Pitch-12°

IDLE 1: SPORT FLIGHT

	Throttle 油門	Pitch 螺距
5	100%	+10~-+12°
4	75%	
3	70%	+5°
2	75%	
1	80%	-5°

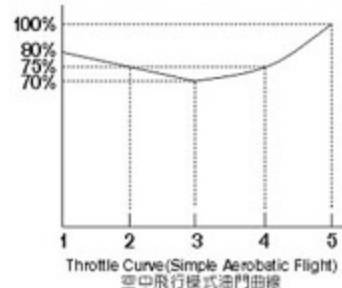

IDLE 2: 3D FLIGHT

	Throttle 油門	Pitch 螺距
5	100% High 100% 高	+12°
3	80% Middle 80% 中	0°
3	100% Middle 100% 中	0°
1	100% Low 100% 低	-12°

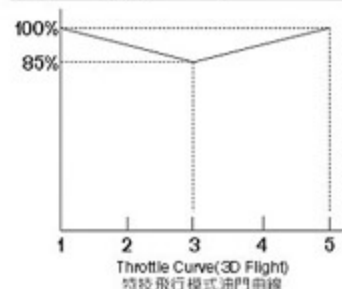

1. Pitch range : Approx. ±13° degrees.
2. If the pitch is set too high, it will result in shorter flight duration and poor motor performance.
3. Setting the throttle to provide a higher speed is preferable to increasing the pitch too high.
1. 螺距(Pitch)總行程約 ±13°
2. 過大螺距設定, 會導致動力與飛行時間降低。
3. 動力提升以較高轉速的設定方式, 優於螺距過大的設定。

BATTERY 電池: ALIGN Li-Poly 44.4V 3300mAh

Motor Pinion Gear 馬達主齒	Main Rotor Blade 主旋翼規格	Pitch 螺距		Current(A) approx. 電流(A)大約值	Throttle Curve 油門曲線	RPM approx. 主旋翼轉速大約值
13T	600mm Carbon Fiber Blades 600碳纖維旋翼	Hover 停懸	+5°	13	0/50/65/85/100%	1750
		Idle	0°	19	85%Middle中	2500
			0°	23.6	100/100/100/100/100%	2720
			±12°	58		2470

NOTE: Please use a pitch gauge to adjust the pitch value. Incorrect excess pitch setting will result poor helicopter performance and reduce ESC's life and battery's life.

註: 請務必使用螺距規來量測調整螺距, 不正確的過大螺距設定不但無法發揮直昇機的特性, 反會影響到無刷調速器與電池的壽命。

RCM-BL600MX 510KV MOTOR RCM-BL600MX 510KV 無刷馬達

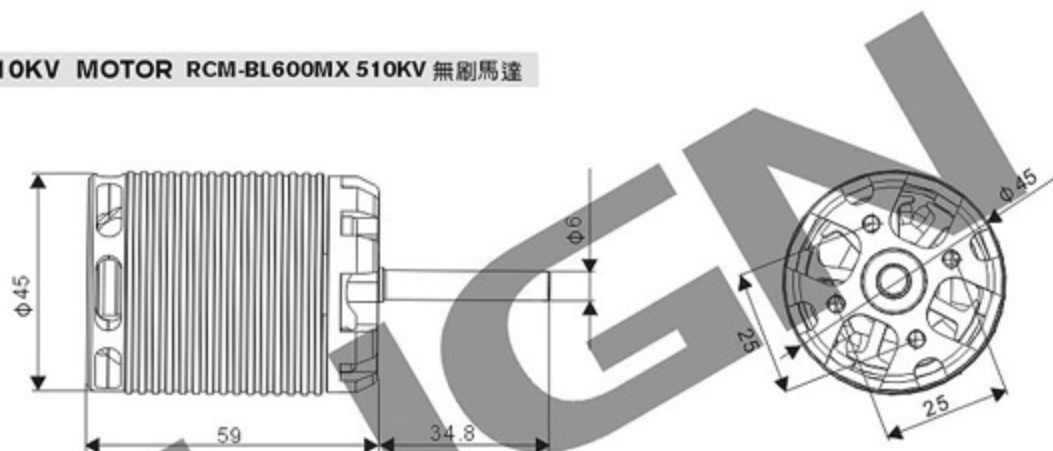

Specification 尺寸規格

KV	KV值	510KV(RPM/V)	Input voltage	輸入電壓	DC 11.1~50.4V
Stator Arms	矽鋼片槽數	12	Magnet Poles	磁鐵極數	10
Max continuous current	最大持續電流	75A	Max instantaneous current	最大瞬間電流	125A(5sec)
Max continuous power	最大持續功率	3300W	Max instantaneous power	最大瞬間功率	5500W(5sec)
Dimension	尺寸	Shaft 6x45x59mm	Weight	重量	Approx. 340g

Illustration 接線示意圖



The motor rotates in different direction with different brand ESCs. If the wrong rotating direction happens, please switch any two cables to make the motor rotates in right direction.

由於各品牌電子變速器的馬達啟動轉向不盡相同, 若發生轉向錯誤時, 請將馬達與電子變速器的接線任兩條對調即可。

HELICOPTER CG CHECK PROCEDURE 直昇機機體重心檢視方式

After installed the battery, hold the helicopter as shown. Once the helicopter stops rotating, the helicopter's CG can be seen at where the head is pointing relative to the main shaft.

電池固定後，將直昇機如圖示舉起，等待直昇機停止轉動後檢視機頭方向，正確重心應落在機身（主軸附近）位置。

Adjust the frame's CG within +/- 60 degrees from level.

以水平線上下夾角 60° 內為適當的範圍來調整機體的重心。

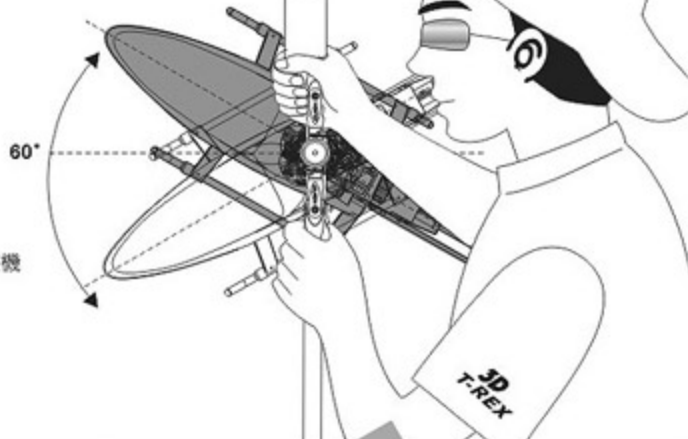

Please practice simulation flight before real flying 飛行前請事先熟練電腦模擬飛行

A safe and effective practice method is to use the transmitter flying on the computer through simulator software sold on the market. Do a simulation flight until you familiarize your fingers with the movements of the rudders, and keep practicing until the fingers move naturally.

1. Place the helicopter in a clear open field (Make sure the power OFF) and the tail of helicopter point to yourself.
2. Practice to operate the throttle stick (as below illustration) and repeat practicing "Throttle high/low", "Aileron left/right", "Rudder left/right", and "Elevator up/down".
3. The simulation flight practice is very important, please keep practicing until the fingers move naturally when you hear operation orders being call out.

在還沒瞭解直昇機各動作的操控方式前，嚴禁實機飛行，請先進行電腦模擬飛行的練習，一種最有效、最安全的練習方式，就是透過市面販售的模擬軟體，以遙控器在電腦上模擬飛行，熟悉各種方向的操控，並不斷的重複，直到手指可熟練的控制各個動作及方向。

1. 將直昇機放在空曠的地方(確認電源為關閉)，並將直昇機的機尾對準自己。
2. 練習操作遙控器的各搖桿(各動作的操作方式如下圖)，並反覆練習油門高/低、副翼左/右、升降舵前/後及方向舵左/右操作方式。
3. 模擬飛行的練習相當重要，請重複練習直到不需思索，手指能自然隨著喊出的指令移動控制。



Mode 1	Mode 2	Illustration 圖示
<p>Aileron 副翼</p>	<p>Throttle 油門</p>	<p>Move left 左移</p> <p>Move right 右移</p> <p>Rotate left 左翻</p> <p>Rotate right 右翻</p>
<p>Elevator 升降/前後</p>	<p>Rudder 方向</p>	<p>Fly forward 前進</p> <p>Fly backward 後退</p> <p>Forward rotate 前翻</p> <p>Backward rotate 後翻</p>
<p>Throttle 油門</p>	<p>Rudder 方向</p>	<p>Ascent 上升</p> <p>Descent 下降</p>
<p>Rudder 方向</p>	<p>Aileron 副翼</p>	<p>Turn right 右旋</p> <p>Turn left 左旋</p>

Flight adjustment and notice 飛行調整與注意

★When arriving at the flying field.

★當抵達飛行場



- Check if the screws are firmly tightened.
- Check if the transmitter and receivers are fully charged.
- 再次確認→螺絲是否鎖固?
- 發射器和接收器電池是否足夠。



- Make sure that no one or obstructions in the vicinity.
- For flying safety, please carefully check if every movement and directions are correct when hovering.
- 確認鄰近地區沒有人和障礙物。
- 為了飛行安全，您必須先確認停懸時各項操控動作是否正確。

If there are other radio control aircraft at the field, make sure to check their frequencies and tell them what frequency you are using. Frequency interference can cause your model, or other models to crash and increase the risk of danger.

假使飛行場有其他遙控飛機，請確認他們的頻率，並告知他們你正在使用的頻率，相同的頻率會造成干擾導致失控和大大地增加風險。

- During the operation of the helicopter, please stand approximately 10m diagonally behind the helicopter.
- 飛行時，請站在直昇機後方最少10公尺。



Do not attempt until you have some experiences with the operation of helicopter.
嚴禁無熟練操控飛行經驗者操控飛行。

STARTING AND STOPPING THE MOTOR 啟動和停止馬達

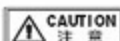

First check to make sure no one else is operating on the same frequency. Then place the throttle stick at lowest position and turn on the transmitter.

首先確認附近沒有其他相同頻率的機，然後打開發射器將油門搖桿推到最低點。

★Check the movement.

★動作確認

- Are the rudders moving according to the controls?
- Follow the transmitter's instruction manual to do a range test.
- 方向舵是否隨著控制方向移動?
- 根據發射器說明書進行距離測試。



Check if the throttle stick is set at the lowest position.

確認油門搖桿是在最低的位置。

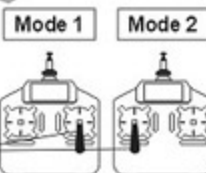

ON! Step1

First turn on the transmitter.
先開啟發射器



ON! Step2

Connect to the helicopter power
接上直昇機電源



OFF! Step3

Reverse the above orders to turn off.
關閉電源時請依上述操作動作反執行。

This procedure is best performed on soft surfaces such as grass. The use of rubber skid stopper is recommended on hard surface to prevent vibration feedback from the ground to 3GX, resulting in over-corrections.

將直昇機置於柔軟地面上，建議硬地起飛腳架裝上避震墊圈。避免升空前腳架與過硬的地面震動太大反饋至機身上的3GX，影響無平衡翼系統升空前過度修正。

Rubber skid stoppers

installed

裝上避震墊圈

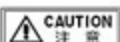
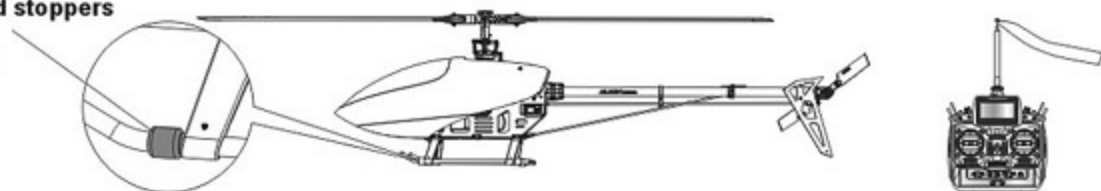

If swashplate should tilt prior to lift off, do not try to manually trim the swashplate level. This is due to vibration feedback to the 3GX, and will disappear once helicopter lifts off the ground. If manual trim is applied, helicopter will tilt immediately after liftoff.

直昇機離地前，十字盤可能因3GX受震動的反饋，使十字盤有傾斜的情形，此時請勿刻意將十字盤修正為水平狀態，此現象只要離地升空時立即解除，可平穩升空；若刻意將十字盤修正為水平時，反而會造成3GX過度修正，一離地即偏往修正方向的危險。

Main rotor adjustments 主旋翼雙槳平衡調整

1. Before adjusting, apply a red piece of tape on one blade, or paint a red stripe with a marker or paint to identify on blade.
2. Raise the throttle stick slowly and stop just before the helicopter lifts-off ground. Look at the spinning blades from the side of the helicopter.
3. Look at the path of the rotor carefully. If the two blades rotate in the same path, it does not need to adjustment. If one blade is higher or lower than the other blade, adjust the tracking immediately.

1. 調整前先在其中一支主旋翼的翼端，貼上有顏色的貼紙或畫上顏色記號，方便雙槳調整辨識。
2. 慢慢的推起油門搖桿到高點並且停止，在飛機離開地面前，從飛機側邊觀察主旋翼轉動。
3. 仔細觀察旋翼軌跡(假如兩支旋翼移動都是相同軌跡，則不需要調整;可是如果一支旋翼較高或較低產生“雙槳”的情形時，則必須立刻調整軌跡)。

- A. When rotating, the blade with higher path means the pitch too big. Please shorten pitch linkage rod (A) for regular trim.**
B. When rotating, the blade with lower path means the pitch too small. Please lengthen pitch linkage rod (A) for regular trim.

- A. 旋翼轉動時較高軌跡的主旋翼表示螺距(PITCH)過大，請調短連桿(A)修正。
B. 旋翼轉動時較低軌跡的主旋翼表示螺距(PITCH)過小，請調長連桿(A)修正。

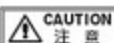

Tracking adjustment is very dangerous, so please keep away from the helicopter at a distance of at least 10m.

調整軌跡非常危險，請於距離飛機最少10公尺的距離。

Incorrect tracking may cause vibrations. Please repeat adjusting the tracking to make sure the rotor is correctly aligned. After tracking adjustment, please check the pitch angle is approx. $+5^\circ$ when hovering.

不正確的旋翼軌跡會導致震動，請不斷重複調整軌跡，使旋翼軌跡精準正確。在調整軌跡後，確認一下Pitch角度在停旋時應為大約 $+5^\circ$ 。

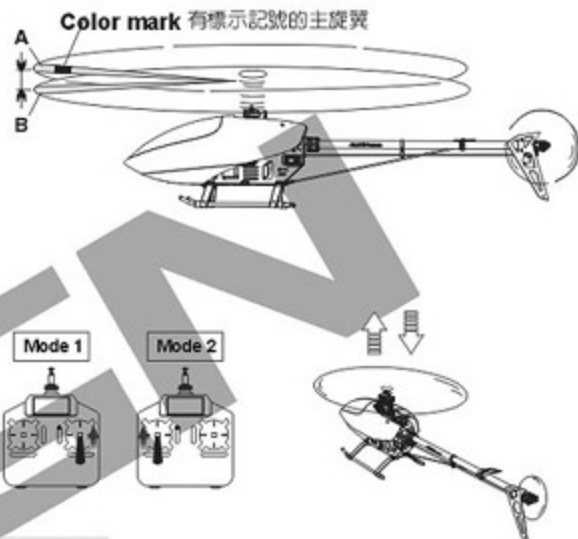

STEP 1 THROTTLE CONTROL PRACTICE 油門控制練習

- ⊙ When the helicopter begins to lift-off the ground, slowly reduce the throttle to bring the helicopter back down. Keep practicing this action until you control the throttle smoothly.
- ⊙ 當直昇機開始離地時，慢慢降低油門將飛機降下。持續練習飛機從地面上升和下降直到您覺得油門控制很順。

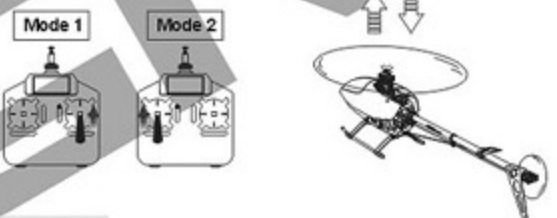

STEP 2 AILERON AND ELEVATOR CONTROL PRACTICE 副翼和升降控制練習

1. Raise the throttle stick slowly.
2. Move the helicopter in any direction back, forward, left and right, slowly move the aileron and elevator sticks in the opposite direction to fly back to its original position.

1. 慢慢升起油門搖桿。
2. 使直昇機依指示：移動向後/向前/向左/向右，慢慢的反向 移動副翼和升降搖桿並將直昇機飛回原來位置。

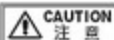
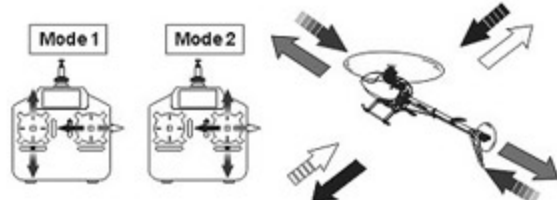

- ⊙ If the nose of the helicopter moves, please lower the throttle stick and land the helicopter. Then move your position diagonally behind the helicopter 10m and continue practicing.
- ⊙ If the helicopter flies too far away from you, please land the helicopter and move your position behind 10m and continue practicing.
- ⊙ 當直昇機機頭偏移時，請降低油門並且降落，然後移動自己的位置到直昇機的正後方10公尺再繼續練習。
- ⊙ 假如直昇機飛離你太遠，請先降落直昇機，並到直昇機後10公尺再繼續練習。

STEP 3 RUDDER CONTROL PRACTICING 方向舵操作練習

1. Slowly raise the throttle stick.
2. Move the nose of the helicopter to right or left, and then slowly move the rudder stick in the opposite direction to fly back to its original position.

1. 慢慢升起油門搖桿。
2. 將直昇機機頭移動左或右，然後慢慢反向移動方向舵搖桿並將直昇機飛回原本位置。

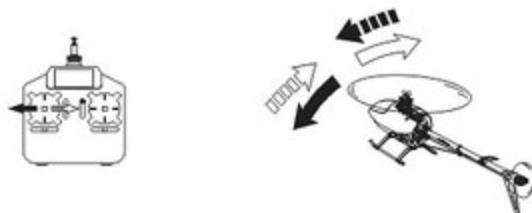

STEP 4

After you are familiar with all actions from Step 1 to 3, draw a circle on the ground and practice within the circle to increase your accuracy.

- ⊙ You can draw a smaller circle when you get more familiar with the actions.

當您覺得 step 1-3 動作熟悉了，在地上畫圈並在這個圈圍的範圍內練習飛行，以增加你操控的準確度。

- ⊙ 當您更加習慣操作動作，您可以畫更小的圈圍。



STEP 5 DIRECTION CHANGE AND HOVERING PRACTICE 改變直昇機方向和練習停懸

After you are familiar with Step 1 to 4, stand at side of the helicopter and continue practicing Step 1 to 4. Then repeat the Step 1 to 4 by standing in front of the helicopter.

當你覺得step 1~4動作熟悉了，站在面對直昇機側邊並繼續練習step 1~4。之後，站在直昇機機頭前方重複步驟練習。

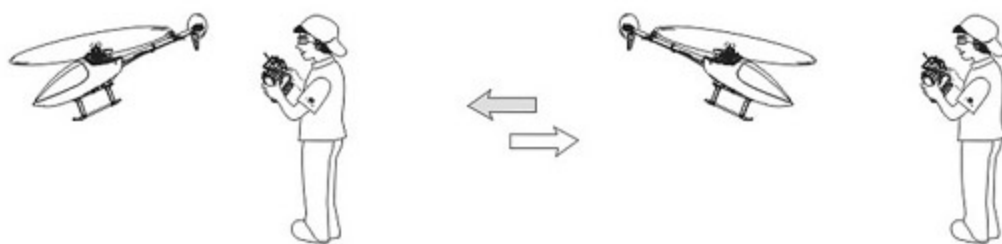

ADJUSTMENT OF EACH TRIM 飛行動作微調

Slowly raise the throttle stick and just as the helicopter lift-off the ground, you can use the trim to correct the action if the helicopter leans in a different direction.

慢慢升起油門搖桿，當直昇機剛剛離開地面時，若直昇機傾向不同方向，可使用微調修正動作。

1. Adjustment of elevator trim

Just before the helicopter lift-off, the nose lean forward/backward...

When leans forward, adjust the trim down.

When leans backward, adjust the trim up.

調整升降舵微調

在直昇機正要起飛時，機頭朝前/後方向偏移...

向前偏移時，微調向下調整。

向後偏移時，微調向上調整。



2. Adjustment of Aileron trim

Just before the helicopter lift-off, the body lean left/right...

When leans right, adjust the trim to left side.

When leans left, adjust the trim to right side.

調整副翼微調

在直昇機正要起飛時，機身朝左/右方向偏移...

向右偏移時，微調向左調整。

向左偏移時，微調向右調整。



17.SETUP EXAMPLES 飛行特性設定對照表

ALIGN

Using Futaba 12ZH transmitter as an example 以Futaba 12ZH遙控器為例

	With emphasis on stability 穩定特性	With emphasis on agility 靈活特性
Main blade pitch Settings(Collective Pitch Settings) 主旋翼螺距設定(集體螺距設定)	Main blade pitch : 11°~12° 主旋翼螺距 : 11°~12° swash pitch : 30%~35%	Main blade pitch : 12°~13° 主旋翼螺距 : 12°~13° swash pitch : 35%~40%
Cyclic pitch settings (Adjust while in DIR mode using AIL/ELE swash AFR) 循環螺距設定(須在DIR模式下設定)	Cyclic Pitch 9° 循環螺距9° swash Aileron : 35% Elevator : 35%	Cyclic Pitch 11° 循環螺距11° swash Aileron : 45% Elevator : 45%
Aileron and Elevator swashplate mixing ratio settings 副翼與升降舵滾轉速率設定	swash Aileron : ≤ 35% Elevator : ≤ 35%	swash Aileron : ≤ 45% Elevator : ≤ 45%
Aileron and Elevator gyro gain settings 副翼與升降舵鎖定感度設定	12 o'clock direction(50%) 12點鐘方向(50%)	11 o'clock direction(40%) 11點鐘方向(40%)



While in DIR setup mode, the transmitter's CCPM swash mixing values for aileron and elevator represent CYCLIC pitch values. These values affect the cyclic roll rates on the aileron and elevator in flying condition. Higher values translate to faster cyclic roll rates. If cyclic roll rate is not improved with increased swash mixing values, this is due to insufficient cyclic pitch. When this happens, cyclic pitch can be increased through the flybarless setup procedure. Maximum cyclic pitch should be limited at 11 degrees.

遙控器上的CCMP十字盤混控SWASH於"DIR"模式設定循環螺距時，Aileron與Elevator比率值的大小代表循環螺距角度的大小，比率愈高循環螺距的角度愈大；而在飛行模式下Aileron與Elevator比率值的大小代表滾轉速率的大小，比率愈高滾轉速率愈快，但若比率調高仍無法提升滾轉速率時表示循環螺距不足，請進入無平衡系統設定模式，將循環螺距加大，但以不超過11°為限。

ALIGN

Specifications & Equipment/規格配備:

Length/機身長 : 1160mm

Height/機身高 : 340mm

Main Blade Length/主旋翼長 : 600mm

Main Rotor Diameter/主旋翼直徑 : 1347mm

Tail Rotor Diameter/尾旋翼直徑 : 260mm

Motor Drive Gear/馬達齒輪 : 13T

Main Drive Gear/主齒輪 : 112T

Autorotation Tail Drive Gear/尾驅動主齒 : 131T

Tail Drive Gear/尾翼傳動齒 : 34T

Drive Gear Ratio/齒輪傳動比 : 8.61 : 1 : 3.85

Weight(With Motor)/空機重(含馬達) : 2290g

